

A 01

**PIECES D'ORIGINE**  
ORIGINAL-TEILE  
GENUINE PARTS  
PIEZAS DE ORIGEM  
RICAMBI ORIGINALI

**2 CV.**

**07/79** ▶

MIC 01117  
Edition 03/91

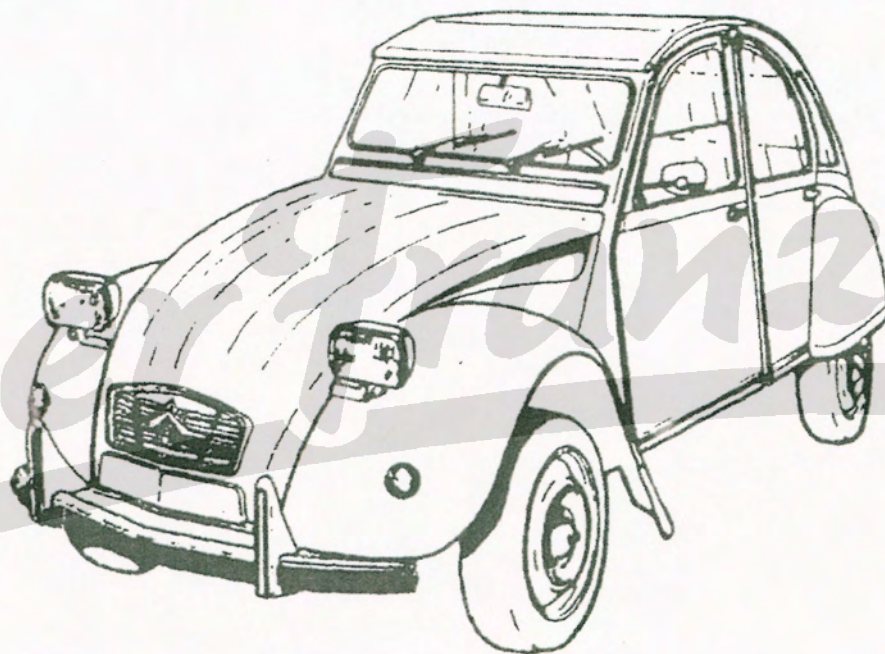

**AUTOMOBILES CITROËN**  
SERVICE A LA CLIENTÈLE  
DÉPARTEMENT PIÈCES DE RECHANGE  
GESTION COMMERCIALE

141. Bd Mac Donald  
B.P. n° 8  
75922 PARIS Cedex 19



A 01

**PIECES D'ORIGINE**  
ORIGINAL-TEILE  
GENUINE PARTS  
PIEZAS DE ORIGEM  
RICAMBI ORIGINALI

**2 CV.**

**07/79** ▶

MIC  
Edition

01117  
03/91

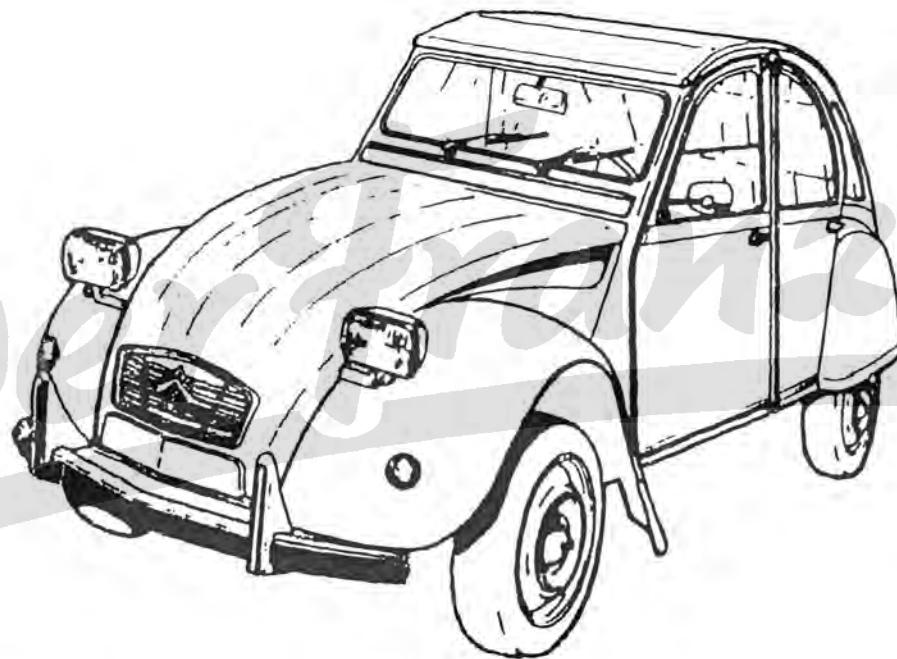

**AUTOMOBILES CITROËN**  
SERVICE A LA CLIENTÈLE  
DÉPARTEMENT PIÈCES DE RECHANGE  
GESTION COMMERCIALE

141, Bd Mac Donald  
B.P. n° 8  
75922 PARIS Cedex 19



Editor's notes:

### **HISTORY:**

This document was compiled from Microfiche Catalogue 01117, which covered cars built between 07/79 and the end of production. It is dated 03/91, some months after the end of production in July 1990, and it came to me in what looked very much like its original envelope, with a label bearing the following legend:

MIC 01117F

2CV

ED 10/98

This I presume was the last issue of parts catalogue for the 2CV. Whether the suffix F means 'Final' or not I don't know!

The fiches were given to me by a kind Belgian artist called Tony Willems who I visited in January 2005 in Gierle, Belgium.

I had the fiches printed out at my local library, then scanned them into my Mac PowerBook, using a Heidelberg Linocolor 1200 scanner. I scanned in B&W and at 300 dpi. I then cleaned up the images and text in GraphicConverter, and used Acrobat Standard 6 to write the .pdf file and to make the index. I'd say it probably took around 12-1500 hours to do over an unemployed winter. The images were pretty poor, and the text illegible in places, so I had to use the index and content lists to check things, before finally going back to the originals and comparing them on a reader with the results of my work, correcting as necessary. I've sought to optimise the pages for viewing on a PC screen, so white space has sometimes been sacrificed in favour of magnification.

I'm bound to have introduced some errors, though I've tried not to. I've mostly left such errors as I found in the original - especially spelling - but may have corrected a few things which were confusing. If you find errors please do let me know!

### **USING THIS DOCUMENT:**

You should find a bookmark index opening with the parts list (to the left of the scanned pages). The index shows the different Fiches and their general topics. Click on the little arrow to the left of a fiche to open the nested index to that Fiche. Click on the topic you wish to view and its first page will automatically appear on the screen.

1117 SYMBOLES UTILISÉS DANS LE TEXTE (Suite) ZEICHENERKLÄRUNG (Forts.) SYMBOLS USED IN THE TEXT (Cont.) LEYENDA DE LOS SIMBOLOS (Cont.) PROSPETTO DE: SIMBOLI (Cont.)		CO	ÉLAS
A-04 ↑		COL	ENS
CAD	DIRECTION A DROITE RECHTSLENKUNG RIGHT HAND STEERING DIRECCION A DERECHA GUIDA A DESTRA	CR	ENT
CAG	DIRECTION A GAUCHE LINKSLENKUNG LEFT HAND STEERING DIRECCION A IZQUIERDA GUIDA A SINISTRA	CU	EXT
CAGE	ÉCROU EN CAGE KAFIGMUTTER CAGE NUT TUERCA EN CAJILLA DADO IN GABBIA	D	FHC
CAN	CANNELURES NUTEN SPLINES RANURAS SCANALATURE	DENT	G
CC	CAOUTCHOUC GUMMI RUBBER CAUCHO GOMMA	DEO	GLACE
CDE	COMMANDE BETAETIGUNG CONTROL MANDO COMANDO	DIAM	GW
CENT	CENTRAL MITTLER CENTRAL CENTRAL CENTRALE	E	H
CHC	VIS TÊTE 6 PANS CREUX INBUSSCHRAUBE SCREW WITH HEXAGON GROOVE TORNILLO CABEZA HUECA HEXAGONAL VITE A TESTA A INCAVO ESAGONALE	ÉCH	HC
		RONDELLE "CONTACT" GERIFFELTE SCHEIBE SHAKE-PROOF WASHER ARANDELA ESTRELLADA RONDELLA STRIATA	RONDELLE ÉLASTIQUE FEDERSCHLEIBE FLEXIBLE WASHER ARANDELA ELASTICA RONDELLA ELASTICA
		VIS COLONNETTE STUTZSCHRAUBE SHOULDERED SCREW TORNILLO COLUMNILLA VITE COLONNETTA	ENSEMBLE SATZTEILE PARTS SET CONJUNTO INSIEME
		RONDELLE CRANTÉE VERZAHNTE SCHEIBE TOOTHED WASHER ARANDELA DENTADA RONDELLA DENTATA	ENTRAXE ACHSABSTAND DISTANCE BETWEEN CENTRES ENTRE EJES INTERASSE
		CUIVRE KUPFER COPPER COBRE RAME	EXTÉRIEUR AUSSENSEITE EXTERNAL EXTERIORE ESTERNO
		COTÉ DROIT RECHTE SEITE RIGHT HAND SIDE LADO DERECHO LATO DESTRO	TÊTE FRAISÉE A 6 PANS CREUX INBUSSCHRAUBE MIT FRAESKOPF COUNTERSUNK HEAD WITH HEX. GROOVE CABEZA AVELLANADA HUECO HEXAGONAL TESTATA SVASATA A INCAVO ESAGONALE
		DENTS OU DENTELURES ZAHNE ODER ZACKEN; TEETH OR NOTCHES DIENTES O ESTRIAS DENTI O STRIE	COTÉ GAUCHE LINKE SEITE LEFT HAND SIDE LADO IZQUIERDO LATO SINISTRO
		DEMANDER EN OUTRE DAZU ORDER IN ADDITION PEDIR ADEMÁS RICHIEDERE INOLTRE	VERSION AVEC GLACE AUSFUEHRUNG MIT SEITLICHEN FENSTERN EQUIPMENT WITH GLAZED SIDE PANELS VERSION CON CRISTALES LATERALES VERSIONE A CRISTALLI LATERALI
		DIAMETRE DURCHMESSER DIAMETER DIAMETRO DIAMETRO	RONDELLE GROWER FEDERRING GROWER RING ARANDELA GROWER RONDELLA GROWER
		ÉPAISSEUR STÄRKE THICKNESS ESPEJOR SPESSORE	HAUTEUR HOHE HEIGHT ALTURA ALTEZZA
		ÉCHAPPEMENT AUSLASS EXHAUS ESCAPE SCARICO	VIS SANS TÊTE A 6 PANS CREUX INBUSSCHRAUBE OHNE KOPF HEX. GROOVE SCREW W O HEAD TORNILLO DE HUECO HEX. SIN CABEZA VITE A INCAVO ESAG. SENZA TESTA

1117 SYMBOLES UTILISÉS DANS LE TEXTE (Suite) ZEICHENERKLÄRUNG (Forts.) SYMBOLS USED IN THE TEXT (Cont.) LEYENDA DE LOS SIMBOLOS (Cont.) PROSPETTO DEI SIMBOLI (Cont.)		LAK	LARGEUR BREITE WIDTH ANCHURA LARGHEZZA	REP	REPÈRE MARKIERUNG MARKING MARCO SEGNO
A-05 ↑		LAT	LATÉRAL SEITLICH LATERAL LATERAL LATERALE	RMP	REMPLECE MODÈLE PRÉCÉDENT ERSETZT DIE FRÜHEREN AUSFÜHRUNGEN REPLACES PREVIOUS MODELS REEMPLAZA LOS MODELOS PRECEDENTES SOSTITUISCE I MODELLI PRECEDENTI
HE	HEXAGONAL SECHSKANT HEXAGONAL EXAGONAL ESAGONALE	LON	LONGUEUR LÄENGE LENGHT LONGITUD LUNGHEZZA	RP	REMPACÉ PAR ERSETZT DURCH SUPERSEDED BY REEMPLAZADO POR SOSTITUITO DA
HEF	ÉCROU AUTO-FREINE SELBSTSICHERNDE MUTTER SELF LOCKING NUT TUERCA AUTOFRENADA DADO AUTOFRENATO	M. AR	MARCHE ARRIÈRE RUECKWAERTISGANG REVERSE MARCHA ATRAS RETROMARCIA	SAUF	EXCEPTÉ MIT AUSNAHME EXCEPT EXCEPTO SALVO
HEX	ÉCROU CRÉNELÉ KRONENMUTTER CASTELLATED NUT TUERCA ALMENADA DADO A CORONA	NFP	NE FOURNISSEONS PLUS NICHT MEHR LIEFERBAR NO LONGER SUPPLIED NO FABRICAMOS MAS NON PIU FORNITO	SUP	SUPÉRIEUR OBEN UPPER SUPERIOR SUPERIORE
HEMB	ÉCROU A EMBASE MUTTER M. BREITER ANLAUFFLÄCHE NUT WITH LARGE BASE TUERCA C/CN BASILLA DADO A Basetta	OPTION	OPTION WAHLWEISE OPTIONAL OPCION OPZIONE	TA	TARAUEUSE BLECHSCHRAUBE THREAD CUTTER SCREW TERRAJANTE FILETTANTE
HERI	ÉCROU HE AVEC RONDELLE IMPERDABLE MUTTER MIT SCHEIBE NUT WITH WASHER TUERCA CON APANDELA IMPERDIBLE DADO CON RONDELLA IMPERDIBILE	PORCOU	MONTAGE PORTE COULISSANTE EINBAU SCHEIBETUER SLIDING DOOR EQUIPMENT MONTAJE PUERTA DESLIZANTE MONTAGGIO PORTIERA SLITTANTE	TCA	VIS A TÊTE CARRÉE VIERKANTKOPFSCHRAUBE SQUARE HEAD SCREW TORNILLO DE CABEZA CUADRADA VITE A TESTA QUADRATA
INF	INFÉRIEUR UNTERN LOWER INFERIOR INFERIORE	PORT LAT	PORTE LATÉRALE BATTANTE TUER DOOR PUERTA PORTIERA	TCB	TÊTE CYLINDRIQUE BOMBÉE GEWÖLBTER ZYLINDERKOPF ROUNDED CYLINDRICAL HEAD CABEZA CILINDRICA COMBADA TESTATA CILINDRICA TONDA
INT	INTÉRIEUR INNEN INTERNAL INTERIOR INTERNO	Q	ÉCROU CARRÉ VIERKANTMUTTER SQUARE NUT TUERCA CUADRADA DADO QUADRATO	TCF	TÊTE CYLINDRIQUE FENDUE SPALTZYLINDERKOPF SLOTTED CYLINDRICAL HEAD CABEZA CILINDRICA HENDIDA TESTA CILINDRICA TAGLIATA
INTM	INTERMÉDIAIRE ZWISCHENGELEGEN INTERMEDIATE INTERMEDIO INTERMEDIO	RAPVOL	RAPPORT VOLUMÉTRIQUE VOLUMENVERHÄLTNIS VOLUME RATIO RELACION VOLUMETRIC RAPPORTO VOLUMETRIC	TF	TÊTE FRAISÉE FRAESKOPF COUNTERSUNK HEAD CABEZA AVELLANADA TESTATA SVASATA

<p>1117</p> <p>A-06 ↑</p>	<p><b>SYMBOLES UTILISÉS DANS LE TEXTE (Suite)</b>          ZEICHENERKLAERUNG (Forts.)          SYMBOLS USED IN THE TEXT (Cont.)          LEYENDA DE LOS SIMBOLOS (Cont.)          PROSPETTO DEI SIMBOLI (Cont.)</p>	<p>TPB</p>	<p>VIE BOMBÉE (POÉLIER)          SCHRAUBE M. GEWOELBTEM KOPF          SCREW WITH ROUNDED HEAD          TORNILLO CABEZA COMBADA          VITE A TESTA TONDA</p>
<p>TFB</p>	<p>TÊTE FRAISÉE BOMBÉE          GEWOELBTER FRAESKOPF          ROUNDED COUNTERSUNK HEAD          CABEZA AVELLANADA COMBADA          TESTATA SVASATA TONDA</p>	<p>TR</p>	<p>TÊTE RONDE          RUNDKOPF          ROUND HEAD          CABEZA REDONDA          TESTA TONDA</p>
<p>TH</p>	<p>TÊTE HEXAGONALE          SECHSKANTKOPF          HEXAGONAL HEAD          CABEZA EXAGONAL          TESTATA ESAGONALE</p>	<p>TT</p>	<p>TOUS TYPES          ALLE TYPEN          ALL TYPES          TODOS TIPOS          TUTTI TIPI</p>
<p>THEMB</p>	<p>VIS A EMBASE          SCHRAUBE MIT BREITEM KOPF          SCREW WITH LARGE HEAD          TORNILLO DE BASILLA          VITE A BASETTA</p>	<p>V</p>	<p>VOLT          VOLT          VOLT          VOLTIO          VOLT</p>
<p>THRI</p>	<p>VIS TH AVEC RONDELLE IMPERDABLE          SCHRAUBE MIT SCHEIBE          SCREW WITH WASHER          TORNILLO CON ARANDELA IMPERDIBLE          VITE CON RONDELLA IMPERDIBILE</p>	<p>W</p>	<p>WATT          WATT          WATT          VATIO          WATT</p>
<p>TO</p>	<p>JOINT TORIQUE          RING DICHTUNG          RING SEAL          JUNTA TORICA          GOMMINO</p>	<p>XT</p>	<p>MONTAGE EXPORT          EXPORT AUSFUEHRUNG          EXPORT FITTING          MONTAJE EXPORT          MONTAGGIO ESPORT</p>
<p>TÔLE</p>	<p>VERSION SANS GLACE          AUSFUEHRUNG OHNE SEITLICHE FENSTER          EQUIPMENT WITH UNGLAZED SIDE PANELS          VERSION SIN CRISTALES LATERALES          VERSIONE SENZA CRISTALLI LATERALI</p>	<p>NOTA</p>	<p>SUSPENSION VARIABLE          =          SUSPENSION HYDRACTIVE</p>

1117 **SYMBOLES UTILISÉS DANS LE TEXTE**  
**ZEICHENERKLAERUNG**  
**SYMBOLS USED IN THE TEXT**  
**LEYENDA DE LOS SIMBOLOS**  
**PROSPETTO DEI SIMBOLI**

A-07 ↑

**AMBULANCE**  
SANITATSWAGEN  
AMBULANCE  
AMBULANCIA  
AMBULANZA

**ACCOUDOIR AVANT**  
ARMLEHNE VORN  
FRONT ARMREST  
CON APOYABRAZOS DELANTERO  
APPOGGIA. BRACCIO. POSTERICRE

**AVEC ASSISTANCE DE FREINAGE**  
MIT SEVRO-BREMSUNG  
WITH BRAKE SERVO  
CON SERVO-FRENO  
CON SERVO-FRENO

**AVEC COMPENSATEUR**  
MIT BREMSAUSGLEICH  
WITH COMPENSATOR  
CON COMPENSADOR  
CON COMPENSATORE

**AVEC COMPENSATEUR INCORPORÉ**  
MIT EINGEBAUTEM BREMSAUSGLEICH  
WITH INTEGRAL COMPENSATOR  
CON COMPENSADOR INTEGRADO  
CON COMPENSATOR INTEGRADO

**AMIANTE**  
MAGNET  
MAGNET  
AMIANTO  
AMIANTO

**ALARME ANTI-VOL**  
DIEBSTAHLSICHERUNG  
THEFT PROTECTION ALARM  
ANTI-ROBO ALARMA  
ANTIFURTO - ALARMI

**ANTI-BLOC ROUE**  
ANTIBLOCKIER SYSTEM  
ABS  
ANTI-BLOQUEO RUEDA  
ANTI BLOCCAGGIO RUOTA

**ANTI-DÉMARRAGE CODE**  
CODE ANLASSSPERRE  
ANTI-START CODE  
ANTIARRANQUE CODIGO

**ATMOSPHÈRE POUSSIÈRES**  
STAUBDRUCKLUFT  
ATMOSPHERIC DUST  
ATMOSFERA POLUOS  
EQUIPAGGIAMENTO CONTRO LA PÓLVERE

**ATTACHE DE REMORQUE**  
ANHANGERKUPPLUNG  
TOWBAR  
ATADURA REMOLQUE  
MONTAGGIO PER TRAINO

**AVERTISSEUR D'OUBLI ÉCLAIRAGE**  
SIGNAL FÜR BELEUCHTUNGS ERINN  
LIGHTING OBLIVION HORN  
BOCINA ALUMBRADO

**BERLINE**  
BERLINE  
SALOON  
BERLINA  
BERLINA

**BERLINE ENTREPRISE 3 PORTES**  
BERLINE 3 TUEREN  
SALOON 3 DOORS  
BERLINA 3 PUERTAS  
BERLINA 3 PORTE

**BERLINE 4 PORTES**  
BERLINE 4 TUEREN  
SALOON 4 DOORS  
BERLINA 4 PUERTAS  
BERLINA 4 PORTE

**BERLINE 5 PORTES**  
BERLINE 5 TUEREN  
SALOON 5 DOORS  
BERLINA 5 PUERTAS  
BERLINA 5 PORTE

**BREAK**  
BREAK - KAROSSERIEN  
ESTATE CAR BODY  
CARROCERIA BREAK  
CARROZZERIA BREAK

**BREAK ENTREPRISE 3 PORTES**  
BREAK KAROSSERIEN - 3 TUEREN  
ESTATE CAR BODY - 3 DOORS  
CARROCERIA BREAK - 3 PUERTAS  
CARROZZERIA BREAK - 3 PORTE

**BREAK FAMILIALE**  
BREAK KAROSSERIEN - FAMILIEN  
ESTATE CAR BODY - FAMILY  
CARROCERIA BREAK - FAMILIAR  
CARROZZERIA BREAK - DOMESTICO

**BREAK 3 PORTES**  
BREAK KAROSSERIEN - 3 TUEREN  
ESTATE CAR BODY - 3 DOORS  
CARROCERIA BREAK - 3 PUERTAS  
CARROZZERIA BREAK - 3 PORTE

**BREAK 5 PORTES**  
BREAK KAROSSERIEN - 5 TUEREN  
ESTATE CAR BODY - 5 DOORS  
CARROCERIA BREAK - 5 PUERTAS  
CARROZZERIA BREAK - 5 PORTE

**BANQUETTE 2/3 - 1/3 - RABATTABLE**  
SITZBANK 2/3 - 1/3 - UMKLAPPBAR  
FOLDING BENCH SEAT 2/3 - 1/3  
BANQUETA 2/3 - 1/3 - PLEGABLE  
SEDILE 2.3 - 1/3 - ARTICULAZIONE

**BANQUETTE ARRIERE RABATTABLE**  
HINTERESITZBANK - UMKLAPPBAR  
REAR FOLDING BENCH SEAT  
BANQUETA TRASERA PLEGABLE  
SEDILE POSTERIORE - ARTICULAZIONE

**BENNE BASCULANTE**  
KIPPER HINTEN  
REAR DUMPER BODY  
CESTO BASCULAR TRASEROS

**CLINIQUE**  
KLINIK  
HOSPITAL  
CLINICA  
CLINICA

**CONDAMNATION LEVE-VITRE ARRIERE**  
HINTERE TUEREN VERRIEGELUNG  
REAR DOOR LOCK KNOB  
SEGURO PUERTA TRASERA  
SERRATURA DI SICUREZZA - PORTA POSTERIORE

**COMMANDE SIEGE AVANT MANUELLE**  
MANULLE BETATIG VORDERSITZ  
FRONT SEAT MANUAL CONTROL  
MANDO ASIEN TO DELANTERO MANUAL  
COMMANDI SEDILE ANTERIORE MANUEL

**COMMANDE SIEGE AVANT ÉLECTRIQUE**  
ELEKTRISCHE BETATIG VORDERSITZ  
FRONT SEAT ELECTRIC CONTROL  
MANDO ASIEN TO DELANTERO ELECTRO  
COMMANDI SEDILE ANTERIORE ELECTRICO

**1117 SYMBOLES UTILISÉS DANS LE TEXTE**  
**ZEICHENERKLÄRUNG**  
**SYMBOLS USED IN THE TEXT**  
**LEYENDA DE LOS SIMBOLOS**  
**PROSPETTO DEI SIMBOLI**

A-08 ↑

**CONDAMNATION CENTRAL. COTÉ CONDUCTEUR**  
ZENTRALVERRIEG. FAHRER  
CENTR. LOCK SYSTEM DRIVER SIDE  
CIERRE DE PUERTAS CENTRAL (CONDUCTOR)  
CHIUSURA CENTRALIZZATA DELLE PORTE (GUIDATORE)

**CONDAMNATION CENTRAL. CONDUCTEUR + PASSAGER**  
ZENTRALVERRIEG. FAHRER + PASSAGI.  
CENTR. LOCK SYSTEM DRIVER + PASS.  
CIERRE DE PUERTAS CENTRAL (CONDUCTOR + PASS.)  
CHIUSURA CENTRALIZZATA DELLE PORTE (GUIDATORE + PASS.)

**CHAUFFAGE**  
HEIZGERAT  
HEATER  
CALEFACCION  
RISCALDATORE

**CEINTURE DE SÉCURITÉ ARRIÈRE A ENROULEUR**  
AUFROLLGURT HINTEN  
REAR INERTIA-REEL SAFETY BELT  
CINTURON SEGUR. TRAS. CON ENROL.  
CINTURA POSTERIORE - ARROTOLATORE AUTOMATICO

**CEINTURE DE SÉCURITÉ ARRIÈRE STAT.**  
SICHERHEITSGURT  
REAR STATIC SAFETY BELT  
CINTURON SEGUR. TRAS. ESTATICO  
CINTURA POSTERIORE FISSA

**CEINTURE ABDOMINALE AVEC ENROULEUR**  
GURTE MIT AUFROLLER  
INERTIA REEL LAP BELT  
CON ENROLL. Y CINTURON ABDOMIN.  
CINTURA ABDOMINALE - ARROTOLATORE AUTOMATICO

**CEINTURE DE SÉCURITÉ AVANT STAT.**  
STATIKGURT VORN  
FRONT STATIC SAFETY BELT  
ARROLLAR. CINTURON ABDOMINAL  
CINTURA ANTERIORE FISSA

**CEINTURES PASSIVES**  
GURTEL PASSIV.  
PASSIVE SAFETY BELT  
CINTURON PASSIVE  
CINTURA PASSIVA

**CEINTURE DE SÉCURITÉ AVANT A ENROULEUR**  
AUFROLLGURT VORN  
FRONT INERTIA REEL SAFETY BELT  
CINTURON SEGUR. DEL. ESTATICO  
CINTURA ANTERIORE - ARROTOLATORE AUTOMATICO

**CLIMAT TEMPÉRÉ**  
GEMAESSIGTES KLIMA  
TEMPERATE CLIMATE  
CLIMA TEMPERANTE  
CLIMA TAMPERARE

**CLIMAT GRAND FROID**  
SEHR KALTE LAENDER  
VERY COLD COUNTRIES  
CLIMA GRANDE FRIO  
CLIMA GRANDE FREDDO

**CLIMAT TRÈS CHAUD**  
TROPISCHE LAENDER.  
HOT CLIMATE  
CLIMA ISIMO CALIENTE  
CLIMA GRANDE CALORE

**CLIMATISEUR**  
HEIZUNGSANLAGE  
HEATER  
CLIMATIZZADOR  
CLIMATISATORE

**CHAUFFAGE COMPLÉMENTAIRE**  
ZUSATZHEIZUNG  
ADDITIONAL HEATING  
CALENTAMIENTO COMPLEMENTARIO  
RISCALDATORE - COMPLEMENT.

**COLONNE DE DIRECTION RÉGLABLE**  
VERSTELLBARE LENKSAULE  
ADJUSTABLE STEERING COLUMN  
COLUMN DEL VOLANTE REGULANDO  
TUBO PER ALBERO COMMANDO STERZO - REGOLAZIONE

**CHAUFFANTE**  
HEIZBAR  
HEATING  
CALENTAMIENTO  
RISCALDAMENTO

**CLAIR**  
KLAR  
CLEAR  
CLARO  
CHIARO

**DISQUES VENTILÉS**  
BREMSSCHEIBE BELUEFTET  
VENTILATED DISC  
DISCO VENTILADO  
DISCO VENTILE

**DIRECTION NON ASSISTÉE**  
OHNE SERVO-LENKUNG  
EXCEPT POWER STEERING  
CONJUNTO DIRECCION NO ASISTIDA  
STERZO NO SERVO COMMANDO

**DIRECTION ASSISTÉE**  
SERVO-LENKUNG  
POWER STEERING  
CONJUNTO DIRECCION ASISTIDA  
STERZO CON SERVO COMMANDO

**DIRECTION ASSISTÉE VARIABLE**  
SERVOLENKUNG VARIABLE  
VARIABLE POWER STEERING  
DIRECCION ASISTIDA VARIABLE  
STERZO CON SERVO COMMANDO VARIAB.

**EMPATTEMENT COURT**  
RADSTAND - KURZ  
WHEELBASE - SHORT  
BATALLA - CORTO  
PASSO - CORTO

**EMPATTEMENT LONG**  
RADSTAND - LANGUE  
WHEELBASE - LENGTH  
BATALLA - LONG.  
PASSO - LUNGHE.

**ESSUIE-VITRE INTERMITTANT**  
SCHEIBENWISCHER MIT INTERVALL  
INTERMITTENT WINDOW WIPER  
LIMPIAPARABRISAS INTERMITENTE  
TERGICRISTALLO - INTERMIT.

**ESSUIE-VITRE AVANT**  
SCHEIBENWISCHER VORN  
FRONT WINDOW WIPER  
LIMPIAPARABRISAS DELANTERAS  
TERGICRISTALLO ANTERIORE

**ESSUIE-VITRE ARRIÈRE**  
SCHEIBENWISCHER HINTEN  
REAR WINDOW WIPER  
LIMPIA LUNETAS TRASERA  
TERGICRISTALLO POSTERIORE

**EMBRAYAGE STANDARD**  
STANDARD KUPPLUNG  
STANDARD CLUTCH  
EMBRAGUE STANDARD  
FRIZIONE STAND.

**EMBRAYAGE AUTOMATIQUE**  
AUTOMAT. KUPPLUNG  
AUTOMATIC CLUTCH  
EMBRAGUE AUTOMATICA  
FRIZIONE AUTOMATICO



1117

**SYMBOLES UTILISÉS DANS LE TEXTE**  
**ZEICHENERKLAERUNG**  
**SYMBOLS USED IN THE TEXT**  
**LEYENDA DE LOS SIMBOLOS**  
**PROSPETTO DEI SIMBOLI**

A-09 ↑

**EQUIPEMENT RADIO**  
**RADIO EINBAUSATZ**  
**RADIO EQUIPMENT**  
**EQUIPO RADIO**  
**RADIO EQUIPAGGIAMENTO**

**FEU DE BROUILLARD ARRIERE**  
**NEBELHECKLEUCHTE**  
**REAR FOG LAMP**  
**PILOTOS NIEPLA TRASEROS**  
**LUCI POSTERIORI ANTINEBBIA**

**FEUX DIURNES**  
**TAGESLEUCHTE**  
**DAYLIGHT RUNNING LIGHTS**  
**LUZ DEL DIA**  
**LUCE DE GIORNO**

**FREIN ARRIERE A TAMBOUR**  
**HINTERE TROMMEL BREMSE**  
**REAR DRUM BRAKE**  
**FRENO DE TAMBOR TRASERO**  
**FRENO A TAMBURO - ANTERIORE**

**FREIN ARRIERE A DISQUE**  
**HINTERE SCHEIBENBREMSE**  
**REAR DISC BRAKE**  
**FRENO DE DISCO TRASERO**  
**FRENO A DISCO ANTERIORE**

**INTERMITTENCE RÉGLABLE**  
**VERSTELLBARE INTERVALLSCHALTUNG**  
**ADJUSTABLE ALTERNATING DEVICE**  
**INTERMITENCIA REGULANDO**  
**INTERMITTENZA RETTIFICA**

**INCLINAISON MANUELLE**  
**NEIGUNG MANUELLE**  
**MANUAL TILT**  
**INCLINACION MANUAL**  
**INCLINAZIONE MANUALE**

**INCLINAISON ÉLECTRIQUE**  
**NEIGUNG ELEKTRISCH**  
**ELECTRIC TILT**  
**INCLINACION ELECTRICO**  
**INCLINAZIONE ELETTRICO**

**LEVE-VITRE ARRIERE - COMMANDE ÉLECTRIQUE**  
**ELEK. FENSTERHEBER HT**  
**ELECT. CONTR. RR WINDOW LIFTER**  
**ELEVALUNA TRASEROS MANDO ELECT**  
**ALZACRISTALLO ELETTRICO, ORDINAZIONE POSTERIORE**

**LEVE-VITRE AVANT - COMMANDE ÉLECTRIQUE AVANT**  
**VERD. FENSTERHEBER MIT VORD. B**  
**FRONT ELECT. CONTR. FRONT WIND. LIFTER**  
**ELEVALUNA MANDO DEL. ELECTRICO**  
**ALZACRISTALLO ANTERIORE ELETTRICO, ORDINAZIONE ANTERIORE**

**LEVE-VITRE**  
**FENSTERHEBER**  
**ELECTRIC CONTROL WINDOW**  
**ELEVALUNAS**  
**ALZACRISTALLO**

**LEVE-VITRE SÉQUENTIEL**  
**SCHEIBENHEBER REIHENFOLGE**  
**SEQUENTIAL WINDOW LIFTER**  
**ELEVALUNA SECUENCIA**  
**ALZACRISTALLO, SEQUENZA**

**LUNETTE ARRIERE CHAUFFANTE**  
**HEIZ - RUECKFENSTER**  
**HEATING REAR WINDOW**  
**LUNETA TRASERA ANTIVAHU**  
**LUNOTTO POSTERIORE TERMICO**

**MONTAGE HP**  
**LAUTSPRECHERMONTAGE**  
**LOUDSPEAKER ASSEMBLY**  
**MONTAJE HP**  
**MONTATURA ALTA-PARLANTE**

**MONTAGE SANS DÉFLECTEUR ARRIERE**  
**MONTAGE OHNE HINT. AUSST. FENS**  
**ASSEMBLY WITH REAR SPOILER**  
**MONTAJE SIN DEFLECTOR TRASERO**  
**MONTATURA SENZA DEFLETTORE POSTERIORE**

**MONTAGE AVEC DÉFLECTEUR**  
**MONTAGE MIT HINT. AUSSTELLFENS**  
**ASSEMBLY WITH REAR SPOILER**  
**MONTAJE CON DEFLECTOR TRASERO**  
**MONTATURA CON DEFLETTORE POSTERIORE**

**MONTAGE AVEC ACCOUDOIR ARRIERE CENTRAL**  
**MONTAGE MIT HINTERE ARMLEHNE**  
**ASSEMBLY WITH REAR CENTRAL ARMREST**  
**MONTAJE CON APOYABRAZOS TRASERO CENTRAL**  
**MONTATURA CON POSTERIORE APPOGGIA CENTRALE**

**NETTOYAGE VITRE PROJECTEUR**  
**SCHEINWERFERWASCHANLANGE**  
**HEADLAMP GLASS CLEANING OR HEAD**  
**LIMPIAFAROS**  
**LAVACRISTALLO**

**NON CHAUFFANTE**  
**NICHT HEIZBAR**  
**NOT HEATED**  
**NO CALENTAMIENTO**  
**NO RISCALDAMENTO**

**OPTION TÉLÉPHONE**  
**WAHLSEISE MIT TELEFON**  
**PHONE OPTION**  
**OPCION TELEFONO**  
**OPZIONE TELEFONO**

**ORDINATEUR DE BORD**  
**BORDCOMPUTER**  
**DASHBOARD COMPUTER**  
**CALCULADOR**  
**CALCOLATORE DI GUIDA**

**PORCOU**  
**SCHIEBETUR**  
**SLIDING DOOR**  
**PUERTA DESLIZANTE**  
**PORTIERA SLITTANTE**

**PRÉÉQUIPEMENT RADIO**  
**VORAUSRUSTUNG FUR RADIO**  
**RADIO PREEQUIPMENT**  
**PREEQUIPO RADIO**  
**PRE-EQUIPAGGIAMENTO RADIO**

**PAYS FROID**  
**KALTE LAENDER**  
**COLD COUNTRIES**  
**PAISANO FRIO**  
**PAESE FREDO**

**PAYS CHAUD**  
**WARM LAENDER**  
**HEAT COUNTRIES**  
**PAISANO CALIDO**  
**PAESE CALDO**

**POIGNÉES AV. + AR. AVEC CROCHETS**  
**HANDGRIFF (VOR - HINTERE) MIT HAKEN**  
**HANDLE (FRONT - REAR) WITH LOCK**  
**MANECILLA (DELANTERA - TRASERA) CON GANCHO**  
**MANOPOLA (ANTERIORE - POSTERIORE) CON GANCIO**

**POIGNÉES ARRIERE AVEC CROCHETS**  
**HANDGRIFF - VOR - MIT HAKEN**  
**HANDLE - FRONT - WITH LOCK**  
**MANECILLA - DELANTERA - CON GANCHO**  
**MANOPOLA - ANTERIORE - CON GANCIO**

**POMPE A ESSENCE ÉLECTRIQUE**  
**KRAFTSTOFF PUMPE, ELEK.**  
**ELECTRIC FUEL PUMP**  
**ELECTRICO BOMBA DE COMBUSTIBLE**  
**ELETTRICO POMPA BENZINA**

1117 **SYMBOLES UTILISÉS DANS LE TEXTE**  
**ZEICHENERKLÄRUNG**  
**SYMBOLS USED IN THE TEXT**  
**LEYENDA DE LOS SIMBOLOS**  
**PROSPETTO DEI SIMBOLI**

A-10 ↑

**POMPE A ESSENCE MÉCANIQUE**  
KRAFTSTOFF PUMPE, MECA.  
MECANIC FUEL PUMP  
MECANICO BOMBA DE COMBUSTIBLE  
MECANICO POMPA BENZINA

**PORTE BAGAGES**  
GEPACKROST  
LUGGAGE RACK  
PORTAEQUIPAJES  
RETE PORTAPACCHI

**PROJECTEURS ANTI-BROUILLARD**  
NEBELSCHEINWERFER  
FOG LAMP  
LIMPIAFAROS ANTI NIEBLA  
PROIETTORE SIGILLATO

**PROJECTEURS LONGUE PORTÉE**  
FERNSCHEINWERFER  
HIGH BEAM HEADLIGHT  
FAROS LARGA ALCANCE  
PROIETTORE PORTATA LUNGA

**PLAFONNIER**  
DECKENLEUCHE  
INTERIOR LIGHT  
LUZ DE TECHO  
LUCE DI SOFFITTO

**RÉHAUSSE RÉGLABLE AVANT**  
REGULIERBARE ERHOCHUNG VORN.  
FRONT ADJUSTMENT SPACER  
REALCE REGLAJE DELANTERO  
RIALZARE REGOLATO POSTERIORE

**RÉHAUSSE RÉGLABLE AVANT - ARRIERE**  
REGULIERBARE ERHOCHUNG VORN/HINT.  
FRONT REAR ADJUSTMENT SPACER  
REALCE REGLAJE DELANTERO ATRAS  
RIALZARE REGOLATO POSTERIORE - ANTERIORE

**RALLONGÉ**  
VERLANGERUNG  
EXTENSION  
PROLONGADOR  
ALLUNGARE

**RÉFRI**  
KLIMAAANLAGE  
AIR CONDITIONING  
REFRIGERANTE  
REFRIGERANTE

**RÉGULATION DE VITESSES**  
TEMPO-MAT  
SPEED CONTROL  
REGULADOR DE VELOCIDADE  
VELOCITA REGOLARIZZARE

**RÉHAUSSE MANUELLE AVANT CONDUCTEUR**  
MECH. MANUELLE VORD. ERHOCHUNG  
DRIVER FRONT MANUEL EXTENSION

ELEVAZIONE MANUALE - POSTERIORE, GUIDA

**RÉHAUSSE MOTORISÉE**  
MOTORISIERTER ERHOCHUNG  
MOTORIZED SPACER  
MOTOR. REALCE  
MOTOR. ELEVAZIONE

**RÉHAUSSE RÉGLABLE PARALLÈLE**  
PARALELE REGULIERB. ERHOCHUNG  
PARALLEL. ADJUSTMENT SPACER  
REALCE REGLAJE PARALELO  
ELEVAZIONE REGOLATA - PARALLELO

**RÉTROVISEUR EXTÉRIEUR SANS COMMANDE**  
AUSSENSPIEGEL OHNE IN. EINST.  
EXT. REARVIEW MIRROR W/O CONTROL  
RETROVISOR EXT. SIN CONTROL  
SPECCHIO RETROVISORE ESTERNO SENZA ORDINAZIONE

**RÉTROVISEUR EXTÉRIEUR COMMANDE INTÉRIEURE MANUELLE**  
IN. MAN. EINST. AUSSENSPIEGEL  
EXT. REARVIEW MIRROR MAN. INT. CONTROL  
RETRO. EXT. CONTROL INTERIOR MANUEL  
SPECCHIO RETROV. ESTERNO CON ORDINAZIONE INT. MANUALE

**RÉTROVISEUR EXTÉRIEUR CHAUF. COMMANDE INTÉR. MANUELLE**  
IN. MAN. EINST. AUSSENSPIEGEL HEI.  
HT EXT. REARVIEW MIRROR MN. INT. CTR  
RETRO. EXT. ANTIVAHQ CONTROL INT. MANUEL  
SPECCHIO RETROVISORE EST. (RISCALDO.) CON ORDINAZIONE  
INTERNO MANUALE

**RÉTROVISEUR EXTÉRIEUR COMMANDE INTÉRIEURE ÉLECTRIQUE**  
EL. EINST. AUSSENSPIEGEL  
EXT. REARVIEW MIRROR EL. INT. CONTROL  
RETRO. EXT. CONTROL INT. ELECT.  
SPECCHIO RETROVISORE EST. CON ORDINAZIONE INT. ELETTRICO

**RÉTROVISEUR EXTÉRIEUR CHAUF. COMMANDE INTÉRIEURE ELECT.**  
EL. EINST. AUSSENSPIEGEL H.  
HT EXT. REARVIEW MIRROR EL INT. CTR  
RETRO EXT. ANTIVAHQ CONTROL INT.  
SPECCHIO RETROVISORE EST. (RISCALDO.) CON ORDINAZIONE  
INTERNO ELETTRICO

**RÉTROVISEUR EXTÉRIEUR**  
AUSSENRUECKSPIEGEL  
EXTERIOR MIRROR  
RETROVISOR EXT.  
SPECCHIO RETROVISORE ESTERNO

**RÉGULATION TEMPÉRATURE**  
TEMPERATURREGLER  
TEMPERATURE CONTROL  
REGULACION TEMPERATURA  
REGOLATORE TEMPERATURA

**SIÈGE CHAUFFANT**  
HEIZBARER SITZ  
HEATED SEAT  
ASSIENTO CALIENTE  
SEDILE RISCALDO

**SANS PORTE LATÉRALE**  
OHNE SEITENTUER  
W/O SIDE DOOR  
SIN PUERTA LATERAL  
SENZA PORTA LATERALE

**SIÈGE AVANT DROIT**  
VORDERSITZ RECHTS  
FRONT SEAT RIGHT  
ASIENTO DELANTERO DERECHO  
SEDILE ANTERIORE - DESTRO

**SIÈGE AVANT GAUCHE**  
VORDERSITZ LINKS  
FRONT SEAT LEFT  
ASIENTO DELANTERO IZQUIERDO  
SEDILE ANTERIORE - SINISTRO

**SANS CONDAMNATION CENTRALISÉE**  
OHNE ZENTRALVERRIEG.  
W/O CENTRAL LOCKING SYSTEM  
SIN CONDENAÇÃO CENTRAL DE PUERTAS  
SENZA CONDANNA CENTRALE

**SANS ASSISTANCE DE FREINAGE**  
OHNE SEVRO-BREMSE  
W/O BRAKE SERVQ  
SIN AMPLICADOR DE FRENADA  
SENZA FRENATA ASSISTENZA

**1117**      **SYMBOLES UTILISÉS DANS LE TEXTE**  
**ZEICHENERKLÄRUNG**  
**SYMBOLS USED IN THE TEXT**  
**LEYENDA DE LOS SIMBOLOS**  
**PROSPETTO DEI SIMBOLI**

**A-11** ↑

**SANS AMIANTE**  
OHNE MAGNET  
W/O ASBESTOS  
SIN AMIANTO  
SENZA AMIANTO

**SIÈGES ARRIÈRE SÉPARÉS**  
HINT. EINZELSITZE  
SEPARATE REAR SEATS  
ASIENTOS TRAS. SEPARADO  
SEDILE POSTERIORE - SEPARAZIONE

**SANS RÉTROVISEUR EXTÉRIEUR**  
OHNE AUSSEN RUECKSPIEGEL  
OUTSIDE EX. WITHOUT VIEW MIRROR  
SIN RETROVISORES EXTERIORES  
SENZA SPECCHIO RETROVISORE ESTERNO

**SIÈGE AVANT CONDUCTEUR**  
FAHRERSITZ  
FRONT DRIVERS SEAT  
ASIENTO DELANTERO CONDUCTOR  
SEDILE ANTERIORE - GUIDA

**SIÈGE A MÉMOIRE**  
COMPUTERSITZ  
SEAT WITH MEMORISED POSITION  
ASIENTO EN MEMORIA  
SEDILE CON MEMORIA

**SIÈGE AVANT PASSAGER**  
BEIFAHRSITZ  
FRONT PASSENGERS SEAT  
ASIENTO DELANTERO PASAJERO  
SEDILE ANTERIORE - PASSEGGERO

**TOIT FIXE**  
OHNE SCHIEBEDAEL  
FIXED ROOF  
TECHO FIJO  
TETTO FISSO

**TOIT OUVRANT COMMANDE MANUELLE**  
SCHIEBEDACH MANUEL. BETAETIG.  
MANUAL CONTR SUN-ROOF  
TECHO CORREDIZO MANDO MANUAL  
TETTO SCORREVOLE - ORDINAZIONE MANUALE

**TOIT OUVRANT**  
SCHIEBEDACH  
SUN-ROOF  
TECHO CORREDIZO  
TETTO SCORREVOLE

**TOIT OUVRANT COMMANDE ÉLECTRIQUE**  
SCHIEBEDACH ELEKTR. BETAETIG.  
ELECTR. CONTR. SUN-ROOF  
TECHO MANDO ELECTRICO  
TETTO SCORREVOLE - ORDINAZIONE ELETTRICO

**TEINTÉE**  
GETOENT  
TINTED  
TENIDO  
TINTO

**TEINTÉE VERT**  
GETOENT GRÜN  
TINTED GREEN  
TENIDO VERDE  
TINTO VERDE

**TEINTÉE BRONZE**  
GETOENT BRONZE  
TINTED BRONZE  
TENIDO BRONCE  
TINTO BRONZO

**TEINTÉE VERTE + ANTENNE RADIO**  
GETOENT GRÜN + ANTENNE  
TINTED GREEN + AERIAL  
TENIDO VERDE + ANTENA  
TINTO VERDE + ANTENNA

**VITRE PIVOTANTE**  
DREHSCHIEBE  
HINGED WINDOW  
ORDENADOR DE VIAJE  
VETRO GIRANTE

**4 ROUES MOTRICES**  
4 ALLRADANTRIEB  
4 DRIVEN WHEELS  
4 RUEDAS MOTOR  
4 RUOTA MOTRICE

15/02/91 1117 <b>TABEAU DES VUES</b> AUFSTELLUNG DER BILDER TABLE OF PICTURE B01 ↑ <b>TABLA DE VISTAS</b> TABELLA DELLE VEDUTE		<b>GROUPE</b> GROUP GROUP <b>01</b> GRUPO GRUPPO		REFRIGERATEUR RENIFLARD JAUDE CARTOUCHE OELPUMPE - FILTEREINSATZ OIL PUMP - FILTER CARTRIDGE BOMBA DE ACEITE - FILTRO DE ACEITE POMPA OLIO-CARTUCCIA FILTRO OLIO	2250-10	C14 C15
<b>SOUS-GROUPE</b> UNTERGRUPPE SUBGROUP SUBGRUPO SOTTOGRUPPO	<b>NUMERO</b> NUMBER NUMBER NUMERO NUMERO	<b>VUE</b> BILD PICTURE VISTA VEDUTA	<b>BOITE DE VITESSES COMPLETE</b> KOMPLETTES GETRIEBE COMPLETE GEARBOX CAJA DE CAMBIOS COMPLETA CAMBIO DI VELOCITA' COMPLETO	3300-10	D15	
<b>MOTEUR - POCHETTE DE JOINTS</b> MOTOR - DICHTSATZ ENGINE - GASKET KIT MOTOR - JUEGO DE JUNTAS MOTORE - SERIE GUARNIZIONI	0010-10	C02	<b>BOITE DE VITESSES ET CARTERS</b> GERTRIEBEGEHAEUSE GEARBOX HOUSING CARTER DE CAJA DE VELOCIDADES CARTER SCATOLA CAMBIO	3303-10	D14	
<b>CULASSE</b> ZYLINDERKOPF CYLINDER-HEAD CULATA TESTATA	1120-10	C03 C04 C05 C06	<b>CARTER BOITE DE VITESSES - FIXATION</b> GETRIEBEGEHAEUSE - BEFESTIGUNG GEARBOX CASING - FASTENING CARCASA DE LA CAJA DE CAMBIO-FIJACION CORPO DEL CAMBIO DI VELOCITA'-FISSAGGIO	3314-10	D13 D12	
<b>CARTER MOTEUR</b> KURBELGEHAEUSE CRANKCASE CARTER DEL MOTOR BASAMENTO DEL MOTOR	1140-10	C07	<b>COMMANDE DE COMPTEUR</b> GESCHWINDIGKEITSMESSERANTRIEB SPEEDOMETER DRIVE MANDO CUENTAKILOMETROS COMANDO CONTACHILOMETRI	3323-10	D11	
<b>CARTER MOTEUR - FIXATION</b> MOTORGEHAEUSE - BEFESTIGUNG CYLINDER BLOCK - SECURING BLOQUE MOTOR - SUJECION MONOBLOCCO - FISSAGIO	1142-10	C08	<b>ARBRE PRIMAIRE-BALADEUR</b> PRIMAERWELLE-SHIEBEMUFFE PRIMARY SHAFT-SLIDING SLEEVE ARBOL PRIMARIO - DESPLAZABLE ALBERO PRIMARIO-SCORREVOLE	3342-10	D10 D09	
<b>VILEBREQUIN - ARBRE A CAMES</b> MOTORGEHAEUSE - BEFESTIGUNG CYLINDER BLOCK - SECURING BLOQUE MOTOR - SUJECION MONOBLOCCO - FISSAGIO	1212-10	C09 C10 C11	<b>ARBRE SECONDAIRE - PIGNONS - SYNCHROS</b> SEKUNDAERWELLE - ZAHNRAEDER - SYNCHROME SECONDARY SHAFT - GEARS - SYNCHRONIZERS ARBOL SECUNDARIO ALBERO SECONDARIO	3344-10	D08 D07 D06	
<b>POMPE A HUILE-CARTOUCHE FILTRANTE</b> OELPUMPE - FILTEREINSATZ OIL PUMP - FILTER CARTRIDGE BOMBA DE ACEITE - FILTRO DE ACEITE POMPA OLIO CARTUCCIA FILTRO OLIO	2221-10	C12 C13	<b>LEVIER - AXES - FOURCHETTES</b> HEBEL - ACHSEN - GABELN LEVERS - SHAFTS - FORKS PALANCAS - EJES - HORQUILLAS LEVAS-PERNI-FORCELLE	3355-10	D05	

<p>15/02/91  1117 <b>TABLEAU DES VUES</b>  AUFSTELLUNG DER BILDER  TABLE OF PICTURE  B02 ↑ <b>TABLA DE VISTAS</b>  <b>TABELLA DELLE VEDUTE</b></p> <p><b>GROUPE</b>  <b>GROUP</b>  <b>GROUP 01</b>  <b>GRUPO</b>  <b>GRUPPO</b></p>		
<p><b>SOUS-GROUPE</b>  UNTERGRUPPE  SUBGROUP  SUBGRUPO  SOTTOGRUPPO</p>	<p><b>NUMERO</b>  <b>NUMBER</b>  <b>NUMBER</b>  <b>NUMERO</b>  <b>NUMERO</b></p>	<p><b>VUE</b>  <b>BILD</b>  <b>PICTURE</b>  <b>VISTA</b>  <b>VEDUTA</b></p>
<p><b>COMMANDE DE VITESSES-COTE HABITACLE</b>  GANGSCHALTUNG INNENRAUMSEITE  GEAR-CHANGE CONTROL-BINACLE SIDE  MANDO DE VELOCIDADES-LADO BITACORA  COMANDO DELLMARCE - LATO ABITACOLO</p> <p><b>DIFFERENTIEL</b>  DIFFERENTIALGETRIEBE  DIFFERENTIAL  DIFERENCIAL  DIFFERENZIALE</p>	<p>3358-10</p> <p>3430-10</p>	<p>D04 D03</p> <p>D02 D01</p>

15/02/91 1117 01-0010-10 PAGE : 1 C02 ↑	<b>MOTEUR - POCHETTE DE JOINTS</b> MOTOR - DICHTSATZ ENGINE - GASKET KIT MOTOR - JUEGO DE JUNTAS MOTORE - SERIE GUARNIZIONI	51	95 616 725	01 REP A 06/664 - 2 POS -(D) 3157 ▶ -(A) 3157 ▶ -(CH) 3614 ▶	<b>MOTEUR NEUF</b> MOTOR NEU NEW ENGINE MOTOR NUEVO MOTORE NUOVO
- NOTA: LES MOTEURS SONT FOURNIS AVEC: REFRIGERATEUR, ALLUMEUR ET JAUGE D'HUILE SANS VOLANT MOTEUR NI AUTRE EQUIPEMENT 1 POS: ESSENCE SUPER - 2 POS: ESSENCE SANS PLOMB - ANM: DIE MOTOREN WERDEN GELIEFERT: MIT OELKUEHLER, VERTEILER UND OELMESSTAB OHNE SHWNNGRAD UND SONTIGE AUSRUESTUNG - NOTE: ENGINES ARE SUPPLIED WITH: OIL COOLER, IGNIT. DISTRIBUTOR AND OIL DIPSTICK WITHOUT FLYWHEEL AND OTHER EQUIPMENT - NOTA: LOS MOTORES SE ENTREGAN: CON REFRIGERADOR, ENCENDIDO Y VARILLA DE NIVEL DE ACEITE SIN VOLANTE NI OTRO EQUIPO - NOTA: MOTORI SONO FORNITI: CON RADIATORE OLIO, SPINTEROGENO E ASTINA CONTROLLO OLIO SENZA VOLANO NE EQUIPAGGIAMENTO					
01	5 412 403	01 REP A 08/635 - 1 POS DEO-2-75478957	MOTEUR NEUF MOTOR NEU NEW ENGINE MOTOR NUEVO MOTORE NUOVO		
02	5 463 048	01	POCHETTE MOTEUR MOTOR DICHTSATZ ENGIN GASKT KIT JUNTAS DE MOTOR S. GUARN. MOTORE		
51	95 543 284   5 412 403	<b>XT</b> 01 REP A 08/635 - 1 POS -(D) 11/79 ▶ 3156 -(A) 11/79 ▶ -(DK) 11/79 ▶ -(I) 1696 ▶ 2335  01 REP A 08/635 - 1 POS -(D) ▶ 11/79 -(A) ▶ 11/79 -(DK) ▶ 11/79 -(I) ▶ 1895 -(I) 2335 ▶ -(CH) RMP DEO 2-75478937	MOTEUR NEUF MOTOR NEU NEW ENGINE MOTOR NUEVO MOTORE NUOVO		

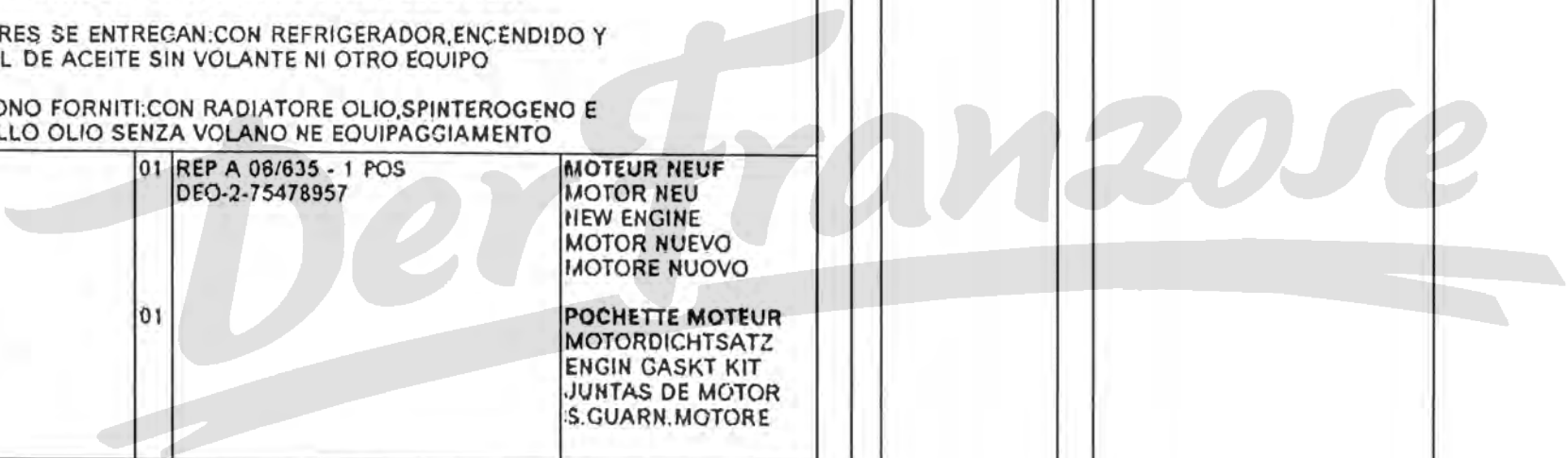

15/02/91  
1117 01-1120-10  
PAGE : 1  
C03 ↑

**CULASSE**  
ZYLINDERKOPF  
CYLINDER-HEAD  
CULATA  
TESTATA

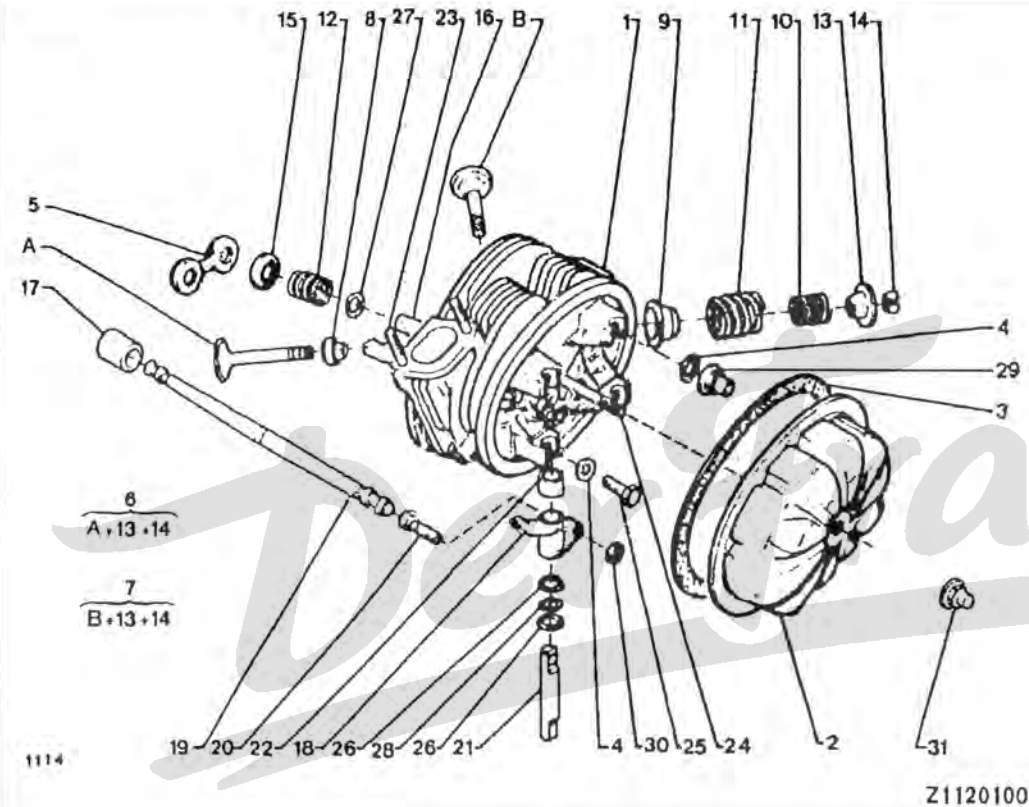

01	5 482 018	01 G-	CULASSE ZYLINDERKOPF CYLINDER-HEAD CULATA TESTATA
	5 482 023	01 D-	
02	75 478 957	02	

**COUVERCLE**  
DECKEL  
CYL-HEAD COVER  
TAPA DE CULATA  
COPERCHIO

03	75 516 398	02	JOINT DICHTUNG COVER GASKET JUNTA DE TAPA GUARNIZIONE
04	5 433 578	08 CU 8,2X14,5X0,9	RONDELLE PLATE FLACHSCHEIBE PLAIN WASHER ARANDELA PLANA RONDELLA PIATTA
05	75 504 636	02	JOINT CAOUTCHOU GUMMIDICHTUNG RUBBER SEAL JUNTA GOMA GUARNIZIONE GOM
06	5 457 476	02 ENS-DIAM 34	SOUPAPE ECH AUSLASSVENTIL EXHAUST VALVE VALVULA ESCAPE VALVOLA SCARICO
07	5 457 475	02 ENS-DIAM 40	SOUPAPE ADM EINLASSVENTIL INTAKE VALVE VALVULA ADM VALVOLA ASPIRAZ
08	AYA 124 63	01 POCHETTE 4 JOINTS	JOINT SOUPAPE VENTIL.DICHTUNG VALVE STEM SEAL RETEN VALVULA GUARNIZIONE
09	75 516 381	01 DIAM 31,6-H 9,5	CENTREUR ZENTRIERSTUECK CENTRING STUD CENTRADOR CENTRATORE
10	AM 124 9 A NFP	04 DIAM INT 17,3	RESSORT SOUPAPE VENTILFEDER VALVE SPRING MUELLE VALVULA MOLLA VALVOLA
11	75 491 633	04 DIAM 24X32,4	
12	75 516 419	04	RESSORT RUCKZUGFEDER RETURN SPRING MUELLE MOLLA RICHIAMO

5/02/91  
 117 01-1120-10  
 PAGE : 2  
 :04 ↑

**CULASSE**  
 ZYLINDERKOPF  
 CYLINDER-HEAD  
 CULATA  
 TESTATA

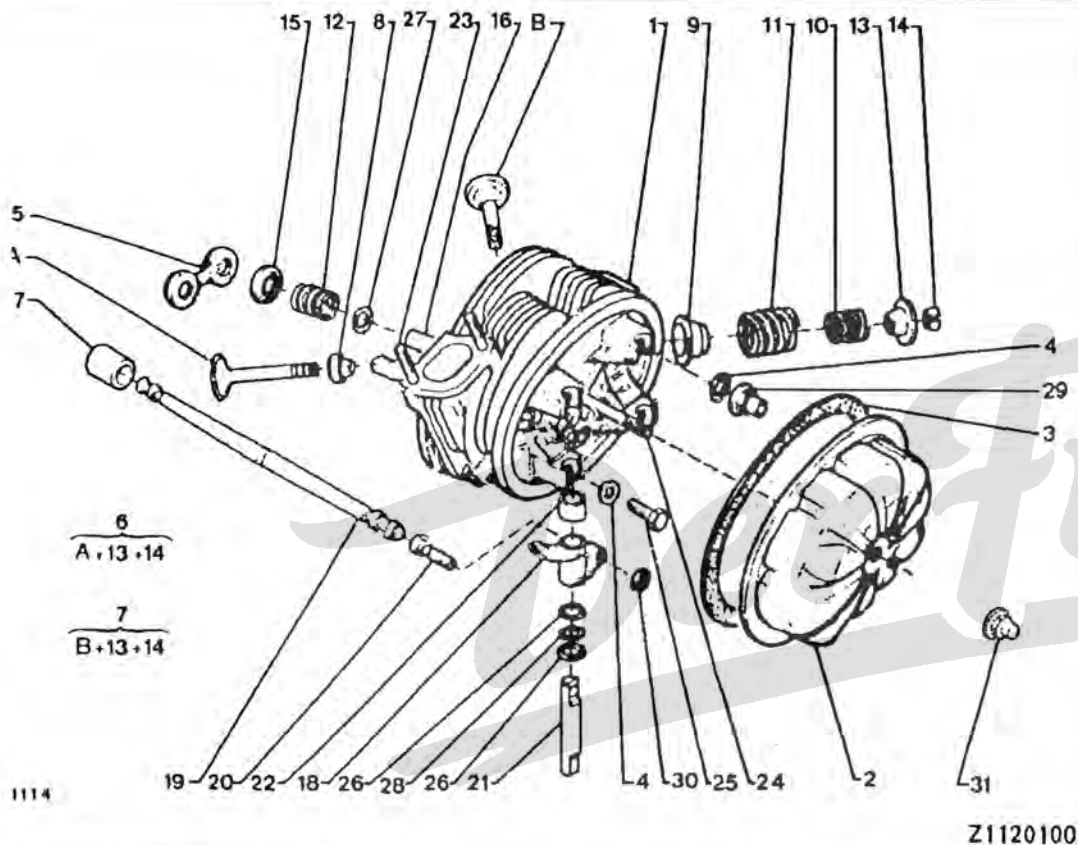

1114

Z1120100

75 516 382

04 DIAM 30 - H 7.95

CUVETTE  
 FEDERTELLER  
 SPRING RETAINER  
 PLATILLO MUELLE  
 SCODELLINO

75 412 011

06 H 7,5

DEMI-CONE  
 HALBKEGEL  
 VALVE HALF-CONE  
 SEMI CONO  
 SEMICONO

15	75 504 637	04		COUPELLE TELLER CUP COPELA SCODELLINO
16	75 516 420	04	1 POS DIAM 18X155 - DIAM 17X34	TUBE DE TIGE ROHR PUSHROD TUBE TUBO DE VARILLA TUBO
	75 421 901	04	2 POS DIAM 18,5 X155 - DIAM 17 X 34	
17	75 467 070	04	1 POS DIAM 24-42	POUSSOIR STOESSSEL VALVE PISTON TAQUE VALVULA PUNTERIA
	75 516 383	04	2 POS DIAM 24,2-42	
18	75 516 387	02	AV D - AR G	CULBUTEUR KIPHEBEL VALV ROCK'R GEAR BALANCIN BILANCIERE
	75 516 390	02	AV G - AV D	
19	75 487 233	04	LOH 286,3	TIGE CULBUTEUR KIPHEBELSTANGE ROCKER PUSHROD VARILLA BALANC ASTA BILANCERE
20	75 516 389	04	DIAM 7X100-25	VIS CULBUTEUR KIPHEBSCHRAUBE ROCKER SCREW TORNILLO REGLAJ VITE REGOLAZ.
21	75 516 392	04	DIAM 14	AXE CULBUTEURS KIPHEBELACHSE VALV ROCK SHAFT EJE BALANCINES PERNO BILANCERI
22	75 516 393	04	DIAM 14X18,5X8,95	ENTRETOISE ABSTANDSSTUECK SHAFT SPACER DISTANCIADOR DISTANZIALE

...!



15/02/91  
1117 01-1120-10  
PAGE : 3  
C05 ↑

**CULASSE**  
ZYLINDERKOPF  
CYLINDER-HEAD  
CULATA  
TESTATA

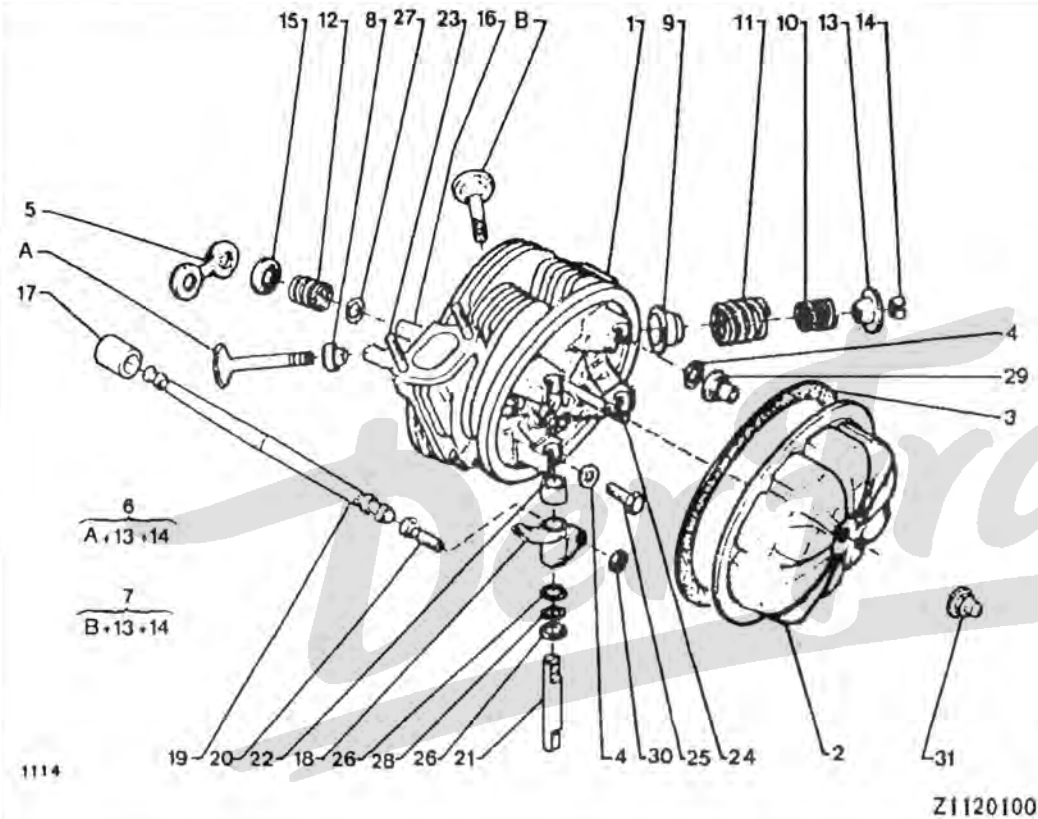

25	26 228 129	04	TR 8X34		VIS FIX AXE ACHS BEF SCHRAU STR SHAFT SCREW TORNILLO EJE VITE FISSAGGIO
26	75 516 394	04	14X19X0,8		RONDELLE SCHEIBE WASHER ARANDELA RONDELLA
27	75 516 421	04	17X25X1,5		
28	79 03 057 096	04	ELAS 14,6X18,8X1,05		
29	75 420 099	06	HE 8X1,25-H 20	▶ 1574	ECROU MUTTER NUT TUERCA DADO
	79 03 033 018	06	DIAM 8 X1,25	1574 ▶	ECROU A EMBASE MUTTER NUT WITH BASE TUERCA CCN BASE DADO A BASETTA
30	75 412 014	04	DIAM 7X1,00-H6		ECROU REGLAGE KIPPEB MUTTER ROCKER NUT TUERCA DADO COLLETTORE
31	75 420 118	02	HE 7X1,00-H20		ECROU BORGNE HUTMUTTER CAP NUT TUERCA DADO CIECO

23	26 152 139 RP 26165029	04	DIAM 7x1,00-36	▶ 1695	GOUJON STEBOLZEN STUD ESPARRAGO PERNO
	26 165 029	04	DIAM 7X1 00-36	1696 ▶	
24	26 162 549	02	DIAM 7X1 00-79		

51	5 482 018	01	G- -(D) -(A) -(DK) -(I) -(I) -(CH)		<b>XT</b>  ▶ 11/79 ▶ 11/79 ▶ 11/79 ▶ 1696 2335 ▶  ▶ 11/79 ▶ 11/79 ▶ 11/79	<b>CULASSE</b> ZYLINDERKOPF CYLINDER-HEAD CULATA TESTATA
	5 482 023	01	D- -(D) -(A) -(DK)			

**CULASSE**  
 ZYLINDERKOPF  
 CYLINDER-HEAD  
 CULATA  
 TESTATA

51

95 615 621  
 NFP

01 D- ENS  
 -(DK) 3157 ▶  
 -(I) 3157 ▶  
 -(A) 3157 ▶  
 -(D) 3157 ▶

CULASSE  
 ZYLINDERKOPF  
 CYLINDER-HEAD  
 CULATA  
 TESTATA

5 505 834  
 RP 95616727

01 G-  
 -(I) 1696 ▶ 3156  
 -(DK) 11/79 ▶ 3156  
 -(D) 11/79 ▶ 3156  
 -(A) 11/79 ▶ 3156

95 615 620  
 NFP

01 G- ENS RMP 5505823  
 -(D) 3157 ▶  
 -(A) 3157 ▶  
 -(I) 3157 ▶  
 -(DK) 3157 ▶

95 616 727

01 G-  
 -(A) 3157 ▶  
 -(DK) 3157 ▶  
 -(I) 3157 ▶  
 -(D) 3157 ▶

5 505 835  
 RP 95616728

01 D-  
 -(I) 1696 ▶ 3156  
 -(D) 11/79 ▶ 3156  
 -(A) 11/79 ▶ 3156  
 -(DK) 11/79 ▶ 3156

95 616 728

01 D-  
 -(A) 3157 ▶  
 -(DK) 3157 ▶  
 -(I) 3157 ▶  
 -(D) 3157 ▶

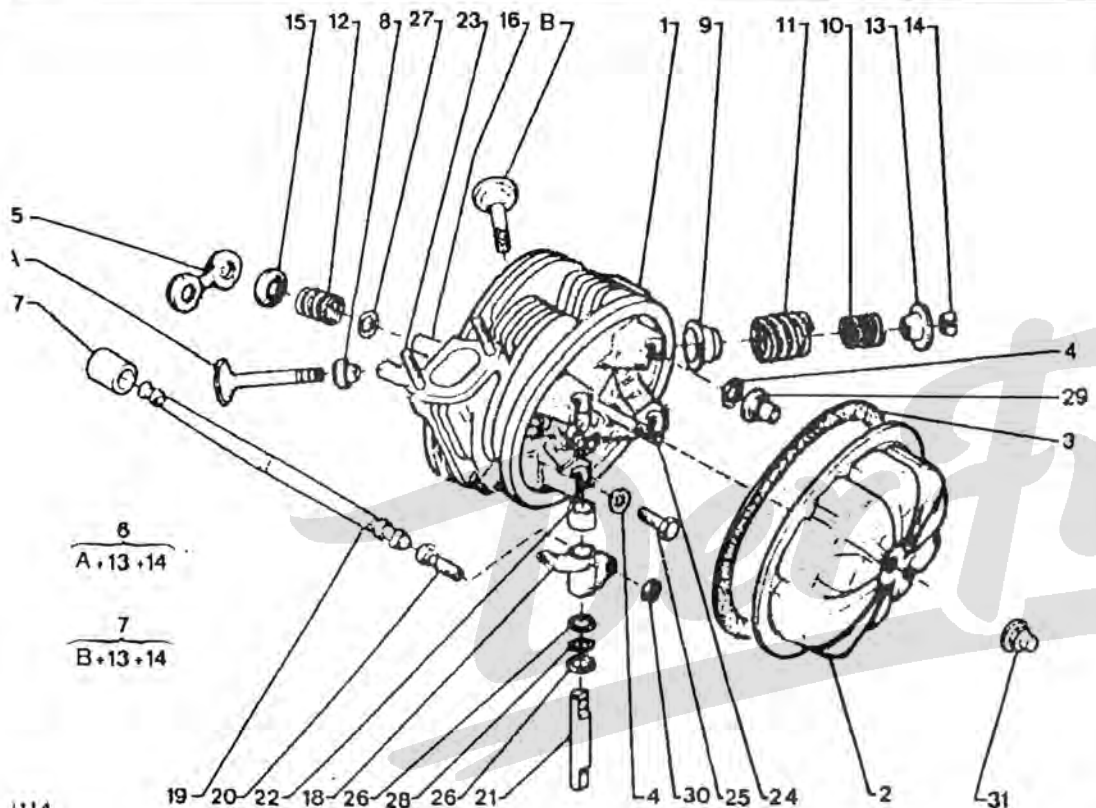

Z1120100

5 482 023

01 (suite)  
 -(I) ▶ 1696  
 -(I) 2335 ▶  
 -(CH)

CULASSE  
 ZYLINDERKOPF  
 CYLINDER-HEAD  
 CULATA  
 TESTATA

5 505 828  
 NFP

01 D-  
 -(D) 11/79 ▶ 3156  
 -(A) 11/79 ▶ 3156  
 -(DK) 11/79 ▶ 3156  
 -(I) 1696 ▶ 3156

15/02/91  
1117 01-1140-10  
PAGE : 1  
C07 ↑

**CARTER MOTEUR**  
KURBELGEHAEUSE  
CRANKCASE  
CARTER DEL MOTOR  
BASAMENTO DEL MOTOR

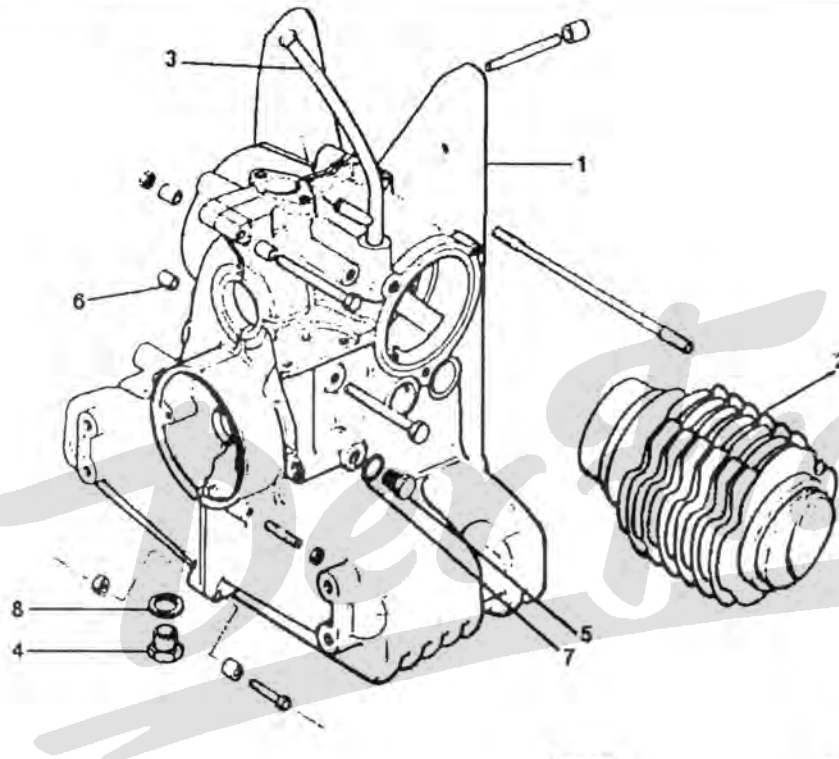

1117

109783

01-1140-10

Z1140100

- NOTA: LES PIECES NON REPEREES VOIR CHAPITRE 01-1142-10

01	5 427 960	01	CARTER CYL ZYLINDERBLOCK CYLINDER BLOCK BLOQUE CILINDRO SCATOLA CILINDR
02	5 426 572	01	DIAM 74-UFLEX  JEU 2 CYL + PIST. 2ZYL.M.KOLBEN SET 2 CYL + PIST JUEGO 2 CYL + PIS 2 CIL + PISTONI

03	75 517 331	01	LON 375	GUIDE DE JAUGE STARFUEHRUNG OIL GAUGE GUIDE GUIA VARILLA GUIDA ASTINA
04	95 573 978	01	DIAM 16X1,50	BOUCHON VIDANGE ABLASS-STOPFEN DRAIN PLUG TAPON VACIADO TAPPO SCARICO
05	AZ 114 91	01	TH 12X1,50	BOUCHON STOPFEN PLUG TAPON TAPPO
06	75 521 078	01	DIAM 12-12	
07	22 458 009	01	CU 12,2X17X1	JOINT DICHTUNG CIRCUIT SEAL JUNTA GUARNIZIONE
08	22 478 009	01	16,3X22X1	
52	95 616 726	01	<b>XT</b> DIAM 74X70-TAUX7,9 -(D) -(A)	JEU 2 CYL + PIST. 2ZYL.M.KOLBEN SET 2 CYL + PIST JUEGO 2 CYL + PIS 2 CIL + PISTONI

**CARTER MOTEUR - FIXATION**  
**MOTERGEHAEUSE - BEFESTIGUNG**  
**CYLINDER BLOCK - SECURING**  
**BLOQUE MOTOR - SUJECION**  
**MONOBLOCCO - FISSAGIO**

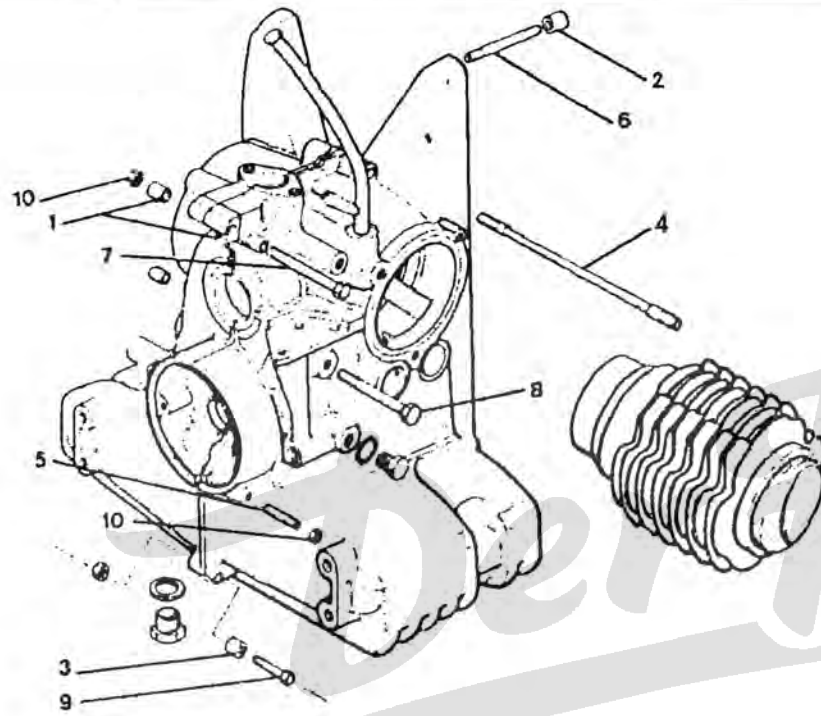

1117 *Les/nd* 01.1142-10  
 Z1142100

- NOTA: LES PIECES NON REPEREES VOIR CHAPITRE 01-1140-10

01	75 521 625	99	7,5X15X20	ENTRETOISE ABSTANDSSTUECK SPACER JUEGO DISTANCIA DISTANZIALE
02	AZ 331 99	02	10X14X27,5	BAGUE CENTRAGE ZENTRIERING CENTRING BUSH CASQUILLO CENT. BOCCOLA CENTRAG
03	75 521 048	02	7,6 X 10 X 11	

04	75 427 959	02	INF DIAM 8X1,125 - DIAM 9X1,125 LON 210,5 DIAM 9X1,125 LON210,5	GOUJON STEBBOLZEN STUD ESPARRAÇO PERNO
	75 427 958	04	SUP DIAM 8X1,125 - DIAM 9X1,25 - LON 239,5 DIAM 9X1,25 · LON239,5	
05	26 163 059	01	DIAM 7X1,00-30,5	-
	26 163 069	01	DIAM 7X1,00-65,5	-
06	26 163 039	01	INF 10X1,50-75	-
	26 163 049	01	INF 10X1,50-80	-
	26 163 029	02	SUP 10X1,50-87	-
07	79 03 001 585	01	TH 7X1,00	VIS TH SCHRAUBE CAPSCREW TORNILLO TH VITE
08	26 212 079	04	TH 10X1,50-85	-
09	79 03 101 776	03	TH 7X1,00-50	-
	79 03 101 786	01	TH 7X1,00-85	-
10	79 03 032 036	07	HE 7X1,00-5,5	ECROU MUTTER NUT TUERCA DADO

15/02/91  
 1117 01-1212-10  
 PAGE : 1  
 C09 ↑

**VILEBREQUIN - ARBRE A CAMES**  
 MOTORGEHAEUSE - BEFESTIGUNG  
 CYLINDER BLOCK - SECURING  
 BLOQUE MOTOR - SUJECION  
 MONOBLOCCO - FISSAGIO

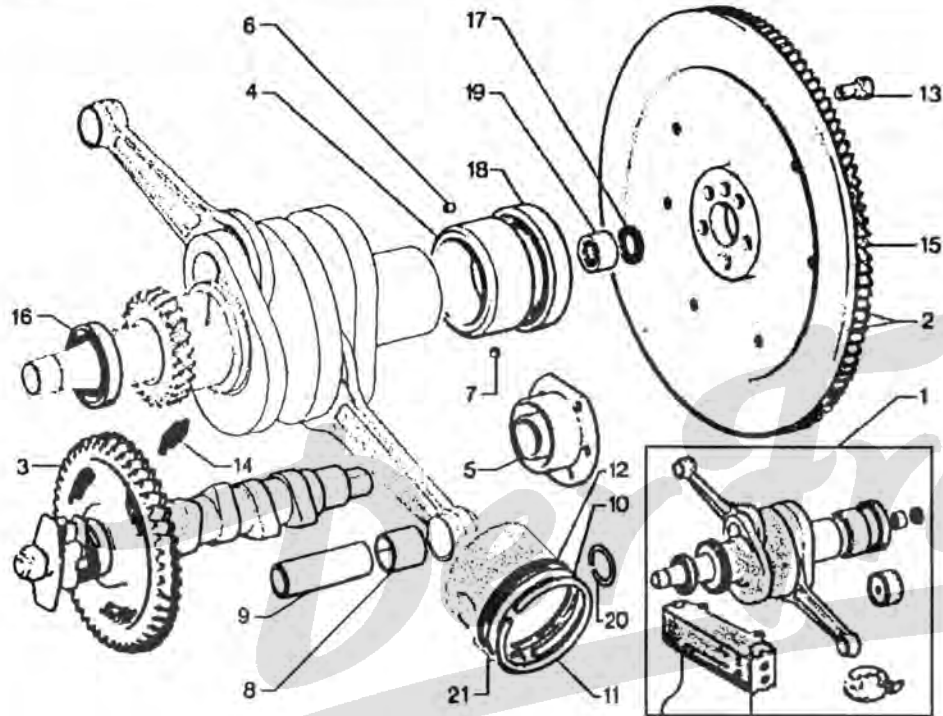

1114

1-121-10  
 Z1212100

- NOTA: LES PISTONS NE SONT VENDUS QU'ASSEMBLES AVEC LES CYLINDRES
- ANM: DIE KOLBEN WERDEN NUR ZUSAMMEN MIT ZYLINDERN GELIEFERT
- NOTE: PISTONS ARE ONLY SOLD ASSEMBLED WITH THE CYLINDERS
- NOTA: LOS PISTONES NO SE VENDEN SINO JUNTOS CON LOS CILINDRO
- NOTA: PISTONI SONO FORNITI INSIEME CON I CILINDRI

01	95 605 456	01 RMP 5503396	2518 ▶	COFFRET EMBIEL. STANGENSET ROD SET CAJA BIELAS COF. BIELLA
02	5 424 930	01 EMBNOR	▶ 1917	VOLANT MOT NE SCHWUNGSCHIE NE FLYWHEEL NEW VOLANTE MOT NE VOLANO MOT NE
	95 559 486	01 EMBNOR	1918 ▶	-
	5 424 931	01 EMBNOR	▶ 2426	-
03	95 533 239	01		ARBRE A CAMES NOCKENWELLE CAMSHAFT ARBOL DE LEVAS ALBERO A CAMES
04	75 516 356	01 1POS-56X63X34-AR		COUSSINET LAGERBUCHSE BEARING COJINETE CUSCINETTO
	75 432 324	01 2POS-55,75X63X34 -AR		-
05	95 548 236	01 RMP 75516372 DEO 1-75488894 - 1-75488893	▶ 04/80	CORPS DE POMPE PUMPENGEHAEUSE PUMP BODY CUERPO DE BOMBA CORPO POMPA
06	26 170 539	01 DIAM 8,5-LON 15 "MECANINDUS"		GOUPILLE STIFT PIN PASADOR COPPIGLIA
07	75 516 347	02 1 POS 8X4-12,25		BAGUE CENTRAGE ZENTRIERRING CENTRING BUSH CASQUILLO CENT. BOCCOLA CENTRAG
	75 516 348	02 2 POS 8,2X4-12,25		-
08	75 420 101	02 20X22X25		DOUILLE BUCHSE CONNECT ROD BRG CASQUILLO BIELA BOCCOLA

.../...

**VILEBREQUIN - ARBRE A CAMES**  
 MOTORGEHAEUSE - BEFESTIGUNG  
 CYLINDER BLOCK - SECURING  
 BLOQUE MOTOR - SUJECION  
 MONOBLOCCO - FISSAGIO

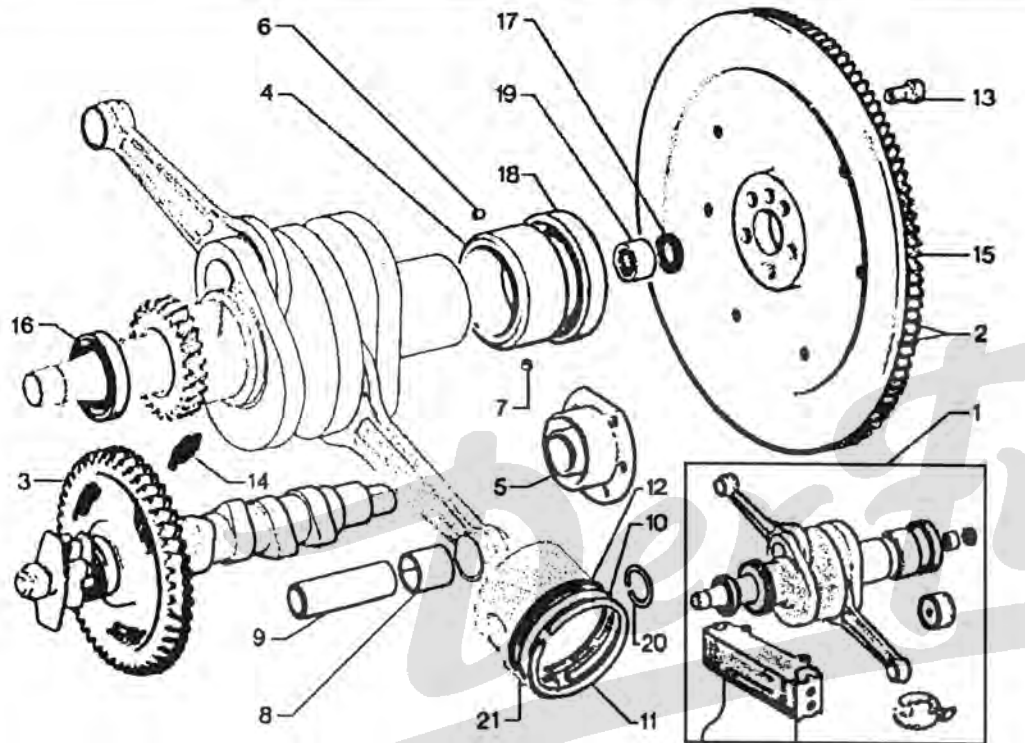

1114

1-121-10

Z1212100

11	5 490 326	02	DIAM 74 - EP 1,75	SEGMENT SUP KOLBENRING OBEN PISTON TOP RING SEGMENTO COMPRE SEGMENTO SUP
12	75 490 327	02	DIAM 74 - E 3,4 "UFLEX"	SEGMENT REFOUL. ABWEISRING SUPPRESSOR RING SEGMENTO REPEL. SEGMENTO SUP
13	75 429 058	05	TH 8X26,5	VIS FIX VOLANT SCHEIB.BEF.SCHR FLYWHEEL SCREW TORNILLO VOLANT VITE VOLANO
14	75 516 364	03	DIAM 10,5-21	RESSORT RUCKZUGFEDER RETURN SPRING MUELLE MOLLA RICHIAMO
15	96 995 258	01	107 DENTS	COURONNE DEMAR. ZAHNKRANZ START RING GEAR CORONA ARRANQUE CORONA
16	79 03 087 086	01	30X42X8	JOINT DE PALIER LAGERDICHTUNG BEARING SEAL JUNTA BANCADA PARAOLIO
	ZC 9612 607 U	01	2POS-30X42,5X8	-
17	79 03 087 053	01	1POS-12X18X3	-
	79 03 087 054	01	2POS-12X 8,2X3	-
	95 495 074	01	1POS-12X18X4	-
	95 496 417	01	2POS-12X18,2X4	-
18	95 496 879	01	56X69X10 2518 ▶	BAGUE CENTRAGE ZENTRIERING SPIGOT-BEARING CASQUILLO BOCCOLA CENTRAG
19	75 420 103	01	1 POS 12X18X16 "CALCAR"	-

.../...

09	75 524 593	01	DIAM 13X20-64	AXE DE PISTON KOLBENBOLZEN PISTON PIN BULON DE PISTON PERNO PISTONE
10	5 420 190 RP AM1216A	02	DIAM 74 - EP 2	SEGMENT RACLEUR OELABSTREIFRING PISTON OIL RING SEGMENTO RASCAD SEGMENTO RASCHI

15/02/91  
 1117 01-1212-10  
 PAGE 3  
 C11 ↑

**VILEBREQUIN - ARBRE A CAMES**  
 MOTORGEHAEUSE - BEFESTIGUNG  
 CYLINDER BLOCK - SECURING  
 BLOQUE MOTOR - SUJECION  
 MONOBLOCCO - FISSAGIO

21

5 503 402

01 ENS-"PAM"

JEU 6 SEGMENTS  
 SATZ 6 RINGE  
 SET 6 PIST RING  
 JUEGO 6 SEGMENT  
 SERIE 6 SEGMENT

95 650 887

02 COTE REPARATION  
 DIAM 74,5

JEU 3 SEGMENTS  
 SATZ 3 RINGE  
 SET 3 RING PIST  
 JUEGO 3 SEGMENT  
 SERIE 3 SEGMENT

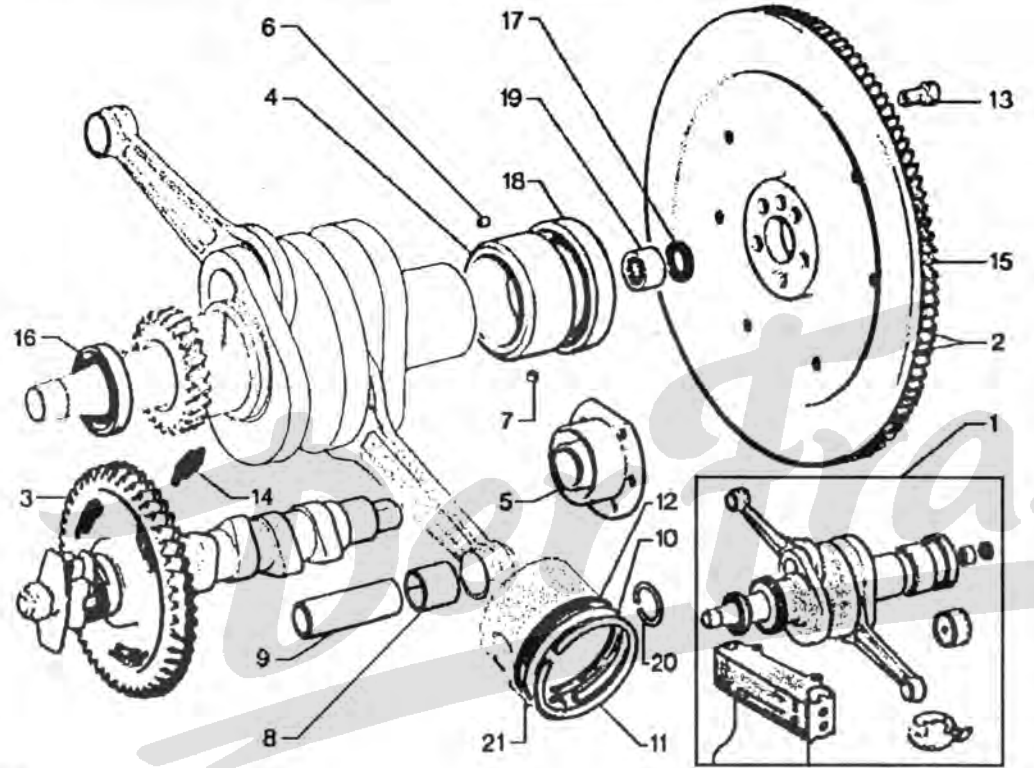

1114

1.121.10

Z1212100

19 75 420 102

01 2 POS 12X18,2X16  
 "CALCAR"

BAGUE CENTRAGE  
 ZENTRIERING  
 SPIGOT-BEARING  
 CASQUILLO  
 BOCCOLA CENTRAG

20 26 205 599

04 E 1,5

ANNEAU D'ARRET  
 VERGASER DIESEL  
 STOP-RING  
 ANILLO RETENCIO  
 ANELLO ARRESTO

15/02/91  
1117 01-2221-10  
PAGE : 1  
C12 ↑

**POMPE A HUILE-CARTOUCHE FILTRANTE**  
OELPUMPE - FILTEREINSATZ  
OIL PUMP - FILTER CARTRIDGE  
BOMBA DE ACEITE- FILTRO DE ACEITE  
POMPA OLIO-CARTUCCIA FILTRO OLIO

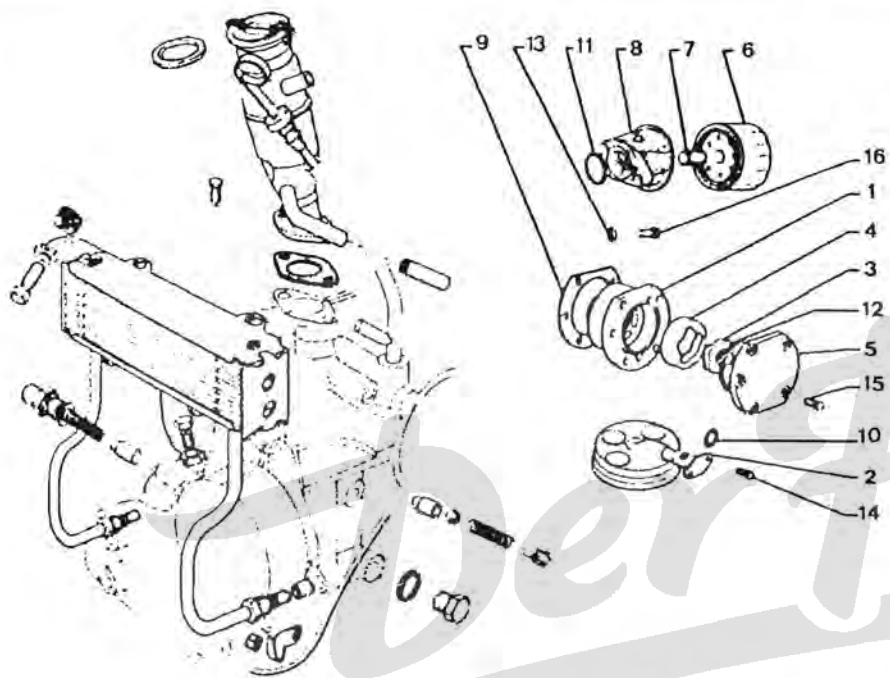

1117  
17-1,19+20+22+34+37  
[ 6/89 ]  
01-2221.10  
22221100

- NOTA: LES PIECES NON REPEREES VOIR CHAPITRE 01-2250-10

01	95 548 236	01 RMP 75516372 04/80 ▶ DEO 1-75488893 1-75488894	CORPS DE POMPE PUMPENGEHAEUSE PUMP BODY CUERPO DE BOMBA CORPO POMPA
02	75 516 403	01 DIAM 89	TAMIS D'HUILE OELSIEB OIL SCREEN FILTRO TAMIZ FILTRO OLIO

03	75 516 409	01 4 DENT-E 10,5 ▶ 04/80	PIGNON CDE PPE PUMP ANTRITZEL PUMP CONTR PINN PINON CDE PPE PIGNONE POMPA
	75 488 893	01 4 DENT-E 11,2 04/80 ▶	-
04	75 516 410	01 5 DENT-E 10,5 ▶ 04/80	-
	75 488 894	01 5 DENT-E 11,2 04/80 ▶	-
05	75 516 411	01 DIAM 54	COUVERCLE PPE ABDECKUNG OIL PUMP COVER TAPA BOMBA COPERCHIO
06	75 518 393	01 "PURFLUX"	FILTRE A HUILE OELFILTER OIL FILTER FILTRO ACEITE FILTRO OLIO
	75 491 083	01 "MAN"	-
07	75 516 416	01 DIAM 16X1,50-28	INSERT EINSATZ INSERT INSERTO INSERTO
08	75 516 414	01 DIAM 77	SUPPORT HALTER FILTER BRACKET SOPORTE SUPPORTO
09	75 492 142	01 5 DIAM 8-E 0 30 09/79 ▶ RMP 75516402	JOINT PPE HUILE PUMPENDICHTUNG OIL PUMP GASKET JUNTA DE BOMBA GUARNIZIONE POM
10	79 03 065 153	01 12,1X15,9X1,9	JOINT DICHTUNG GRBX PLUG GASKT JUNTA DE TAPON GUARNIZIONE
11	24 829 009	01 34X37,8X1,9	-
12	25 111 009	01 54,5X58,3X1,9	-

.../...



15/02/91  
 1117 01-2221-10  
 PAGE : 2  
 C13 ↑

**POMPE A HUILE-CARTOUCHE FILTRANTE**  
 OELPUMPE - FILTEREINSATZ  
 OIL PUMP - FILTER CARTRIDGE  
 BOMBA DE ACEITE- FILTRO DE ACEITE  
 POMPA OLIO-CARTUCCIA FILTRO OLIO

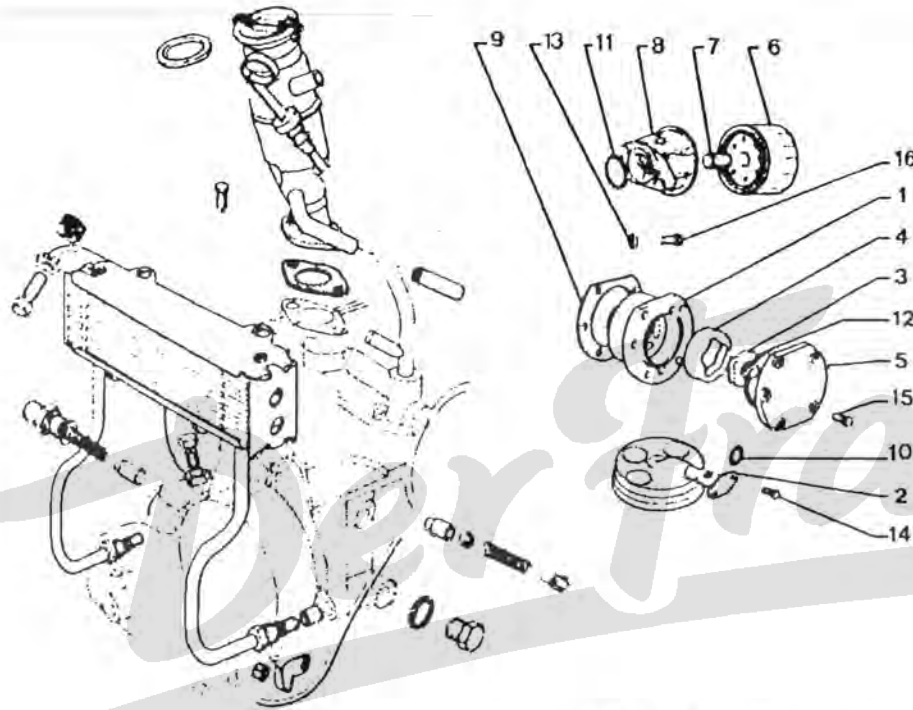

1117

17 = 1+19+20+22+34+37

5/89

01.2221.10  
 Z2221100

13	79 03 058 011	01	DIAM 7,2X14,2-1,4	RONDELLE CONIQU KONUSSCHEIBE SPRING WASHER ARANDELA RONDELLA CONICA
14	79 03 201 012	02	DIAM 5X0,80-14	VIS TH SCHRAUBE CAPSCREW TORNILLO TH VITE
15	75 516 412	05	TH 7X20	

16	26 213 659	05	TH7X65	VIS TH SCHRAUBE CAPSCREW TORNILLO TH VITE
	26 214 459	01	TH7X28	-
17	95 559 620	01	ENS-"PAM" 04/80 ▶	ENS REPARATION REPAR SATZ REPAIR SET JUEGO REPARACI INS RIPARAZIO

15/02/91  
1117 01-2250-10  
PAGE : 1  
C14 ↑

**REFRIGERATEUR RENIFLARD JAUDE CARTOUCHE**  
OELPUMPE - FILTEREINSATZ  
OIL PUMP - FILTER CARTRIDGE  
BOMBA DE ACEITE- FILTRO DE ACEITE  
POMPA OLIO-CARTUCCIA FILTRO OLIO

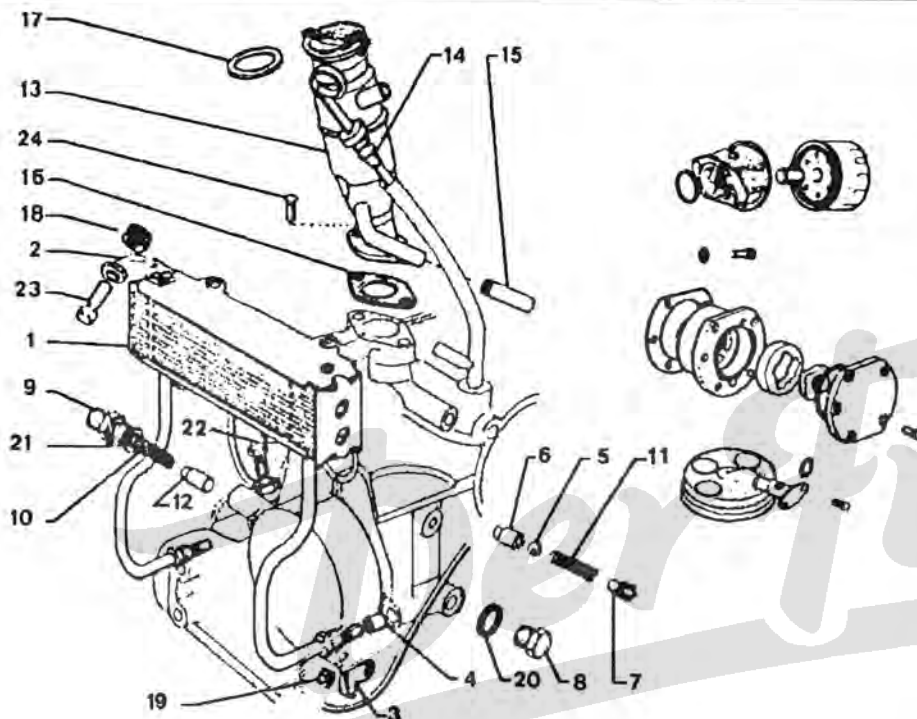

1117

41 = 1+19+20+22+34+37

[ 5/89 ]

01-2250 10

Z2250100

- NOTA: LES PIECES NON REPEREES VOIR CHAPITRE 01-2221-10

01	5 440 576	01		RADIATEUR + JOINT KUEHLER SEAL + OIL COLLER RADIADOR + JUNTAS RADIATORE OLIO
02	95 581 779	01	RMP 75520153	2061 ▶ TUYAU GRAISSAGE SCHMIRROHR GREASE PIPE TUBO ENGRASE TUBO LUBRIFICAZ

03	75 516 417	01	1 DIAM 8	PATTE FIX TUYAU ROHRBEF LASCHE PIPE FIX BRACKT SOP.FIX TUBO STAFFA TUBO
04	75 521 624	02	10,5X13,6X12,5	GARNITURE BESCHLAEGE PIPE LINING GUARNECIDO RIVESTIMENTO
05	24 104 009	01	DIAM 8,5	BILLE DE CLAPET VENTILKUGEL VALVE BALL BOLA DE VALVULA SFERA VALVOLA
06	75 508 466	01	1 POS-11,7X8,8X14,6	SIEGE DE CLAPET VENTILSITZ VALVE SEAT ASIENTO VALVULA SEDE VALVOLA
07	75 508 467	01	2 POS-11,9X8,8X14,6	-
07	75 411 410	01	DIAM 8,5-LON 10	COUPELLE TELLER CENTERING CUP COPELA CENTRAJE SCODELLINO
08	AZ 114 91	01	TH 12X1,50	BOUCHON STOPFEN PLUG TAPON TAPPO
09	75 516 401	01	TH 21X1,50-DIAM 13	-
10	75 403 834	01	15 SPIR-8,5X11,3	RESSORT FEDER PISTON SPRING MUELLE MOLLA
11	75 411 411	01	LON 23,5	-
12	75 516 400	01	DIAM 12 X 8,2 - 29,6	PISTON DECHARGE ENTLASTKOLBEN DISCHARG PISTON PISTON DESCARGA PISTONE SCARICO

.../...

15/02/91  
1117 01-2250-10  
PAGE : 2  
C15 →

**REFRIGERATEUR RENIFLARD JAUDE CARTOUCHE**  
OELPUMPE - FILTEREINSATZ  
OIL PUMP - FILTER CARTRIDGE  
BOMBA DE ACEITE- FILTRO DE ACEITE  
POMPA OLIO-CARTUCCIA FILTRO OLIO

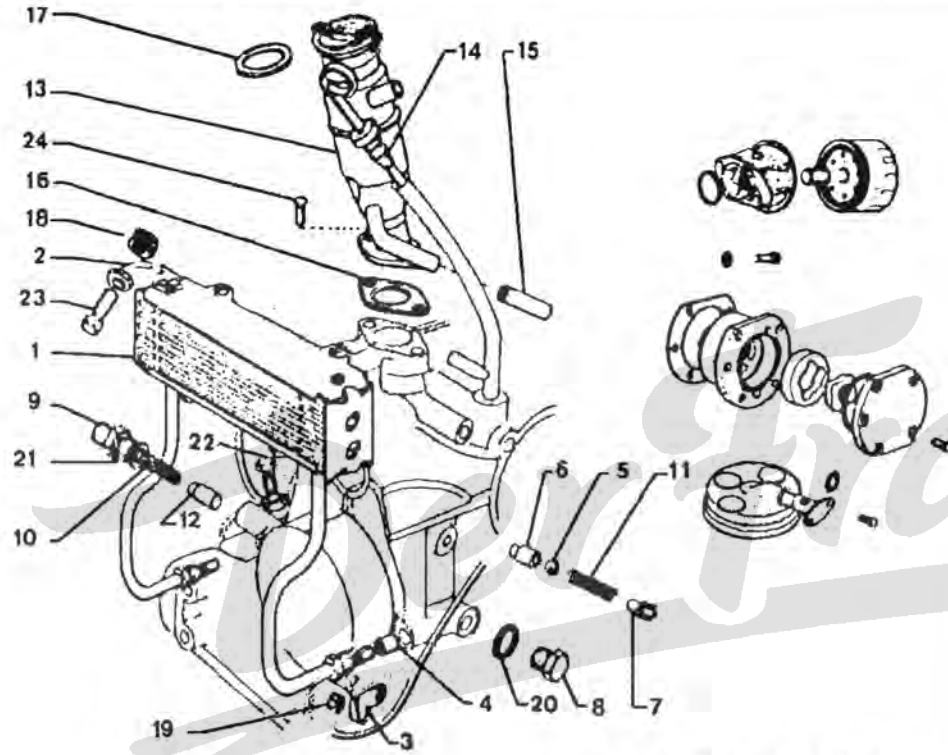

41 = 1+19+20+22+34+37

1117 [6/89] 01-2250 10  
Z2250 100

13	75 515 280	01	RENIFLARD ENTLUEFTER OIL BREATHER RESPIRADERO BOCCHETTONE	23	75 415 425	02	TH7X18 - 1 DIAM 1	-
14	75 503 614	01	LON 473,5 JAUGE D'HUILE OELMESSSTAB ENGINE OIL GAUGE VARILLA NIVEL ASTINA OLIO	24	95 623 773	02	TH7X1.00-25	VIS SCHRAUBE SCREW TORNILLO VITE

15	26 231 549 RP 95655310	01	7X16X40 CAOUTCHOUC					TUYAU DE RETOUR LEITUNG RETURN PIPE TUBO DE RETORNO ASTINA OLIO
16	75 427 388	01	1 DIAM 27 - 2 DIAM 8 ENT 48					JOINT DICHTUNG BREATHER GASKET JUNTA GUARNIZIONE
17	75 420 173	01	53X64X3					-
18	75 412 173	03	DIAM-7,2					JOINT DOUBLE DOPPELDICHTUNG GREASE SEAL JUNTA DOBLE DOPPIA GUARNIZ
19	75 520 086	01						BAGUE ELASTIQUE RING BUSHING CASQUILLO ELAS. BOCCOLA ELAST.
20	22 458 009	01	CU 18.2X17X1					JOINT DICHTUNG CIRCUIT SEAL JUNTA GUARNIZIONE
21	26 178 129	01	20,8X26,5X0,5					JOINT PPE HUILE PUMPENDICHTUNG OIL PUMP GASKET JUNTA DE BOMBA GUARNIZIONE POM
22	75 412 174	01	TH7X18-1 DIAM 2					VIS RACCORD VERB SCHRAUBE UNION-SCREW TORNILLO RACOR VITE RACCORDO

15/02/91  
 1117 01-3300-10  
 PAGE : 1  
 D15 ↓

**BOITE DE VITESSES COMPLETE**  
 KOMPLETTES GETRIEBE  
 COMPLETE GEARBOX  
 CAJA DE CAMBIOS COMPLETA  
 CAMBIO DI VELOCITA' COMPLETO

51

95 640 573

01 C 8 X 33  
 -(D)

**XT**

3628 ▶

BV NEUVE  
 GETRIEBE NEU  
 NEW GEARBOX  
 CAJA CAMBIOS NE  
 SCAT CAMBIO NE

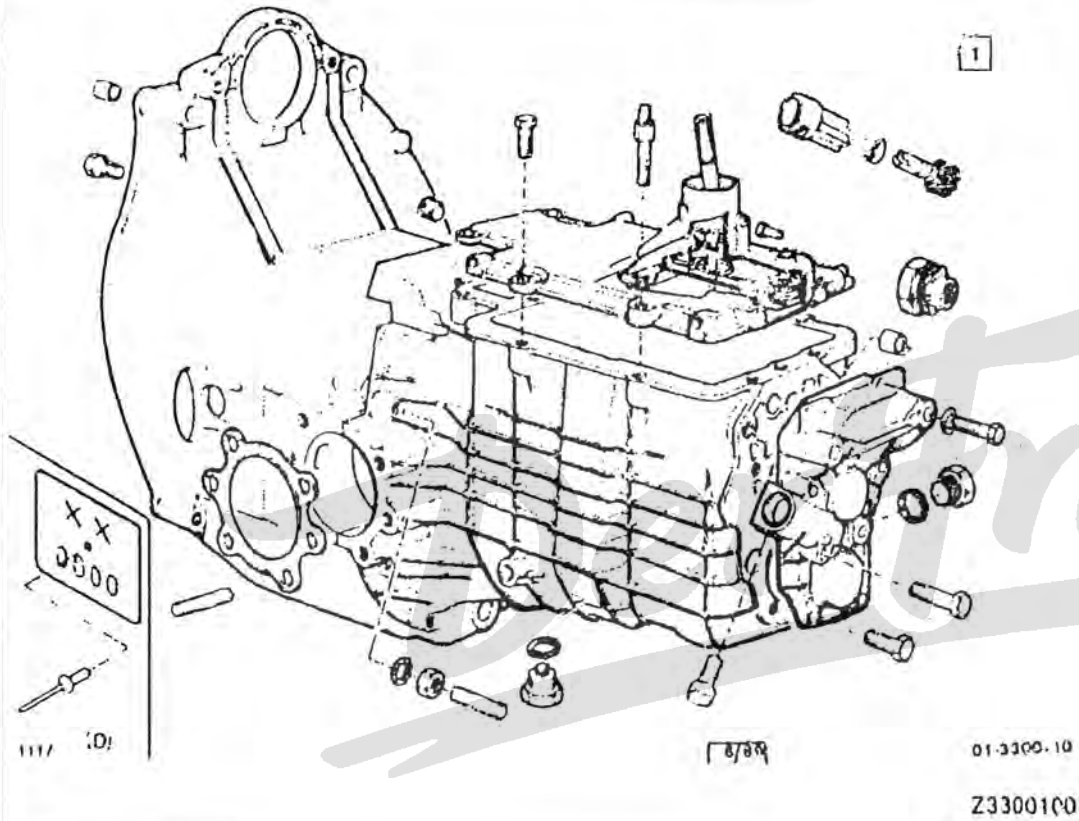

01	5 427 485 NFP	01	FREIN TAMBOUR ▶ 1665	BV NEUVE GETRIEBE NEU NEW GEARBOX CAJA CAMBIOS NE SCAT CAMBIO NE
	95 574 075	01	FREINS A DISQUES 1918 ▶ 1917 EMBCEN ▶ 2426	
	95 571 133	01	EMBNOR 1918 ▶ FREINS A DISQUES	

15/02/91  
1117 01-3303-10  
PAGE : 1  
D14 ↓

**BOITE DE VITESSES ET CARTERS**  
GERTRIEBEGEHAEUSE  
GEARBOX HOUSING  
CARTER DE CAJA DE VELOCIDADES  
CARTER SCATOLA CAMBIO

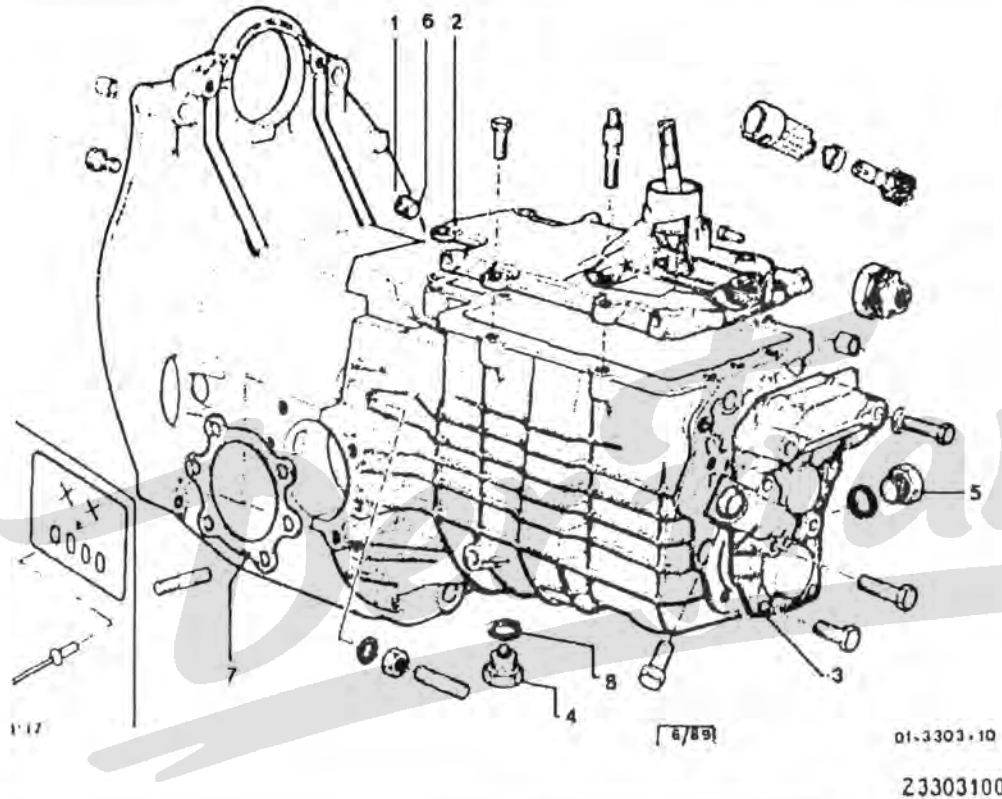

NOTA: LES PIÈCES NON REPEREES VOIR CAPITRES 01-3314-10  
01-3323-10

01	95 563 547	01 RMP AM33101	1666 ▶	CARTER BV GEHAEUSE GEAR-BOX HOUSG CARCASA CARTER
02	75 524 524	01 RMP AM33103 AM33111	02/80 ▶	COUVERCLE BV DECKEL GEAR-BOX COVER TAPA CAJA COPERCHIO

03	AM 331 3 C	01 AR	COUVERCLE BV DECKEL GEAR-BOX COVER TAPA CAJA COPERCHIO
04	95 573 978	01 DIAM 16X1,50	BOUCHON VIDANGE ABLASS-STOPFEN DRAIN PLUG TAPON VACIADO TAPPO SCARICO
05	75 411 362	01 TH 16X1,50	BOUCHON STOPFEN OIL LEVER PLUG TAPON NIVEL TAPPO SCARICO
06	ZC 9613 037 U	01 DIAM 8,10	-
07	AM 331 86 A	02 6-DIAM 9	JOINT DE CARTER GEHAEUSEDICHTUN HOUSING GASKET JUNTA CARCASA GUARNIZIONE CAR
08	22 478 009	02 16,3X22X1	JOINT DICHTUNG DRN PLUG GASKET JUNTA DE TAPON GUARNIZIONE
53	96 995 255	01 AR -(D)	<b>XT</b>  COUVERCLE BV DECKEL GEAR-BOX COVER TAPA CAJA COPERCHIO

**CARTER BOITE DE VITESSES - FIXATION**  
 GETRIEBEGEHAEUSE - BEFESTIGUNG  
 GEARBOX CASING - FASTENING  
 CARCASA DE LA CAJA DE CAMBIO-FIJACION  
 CORPO DEL CAMBIO DI VELOCITA-FISSAGGIO

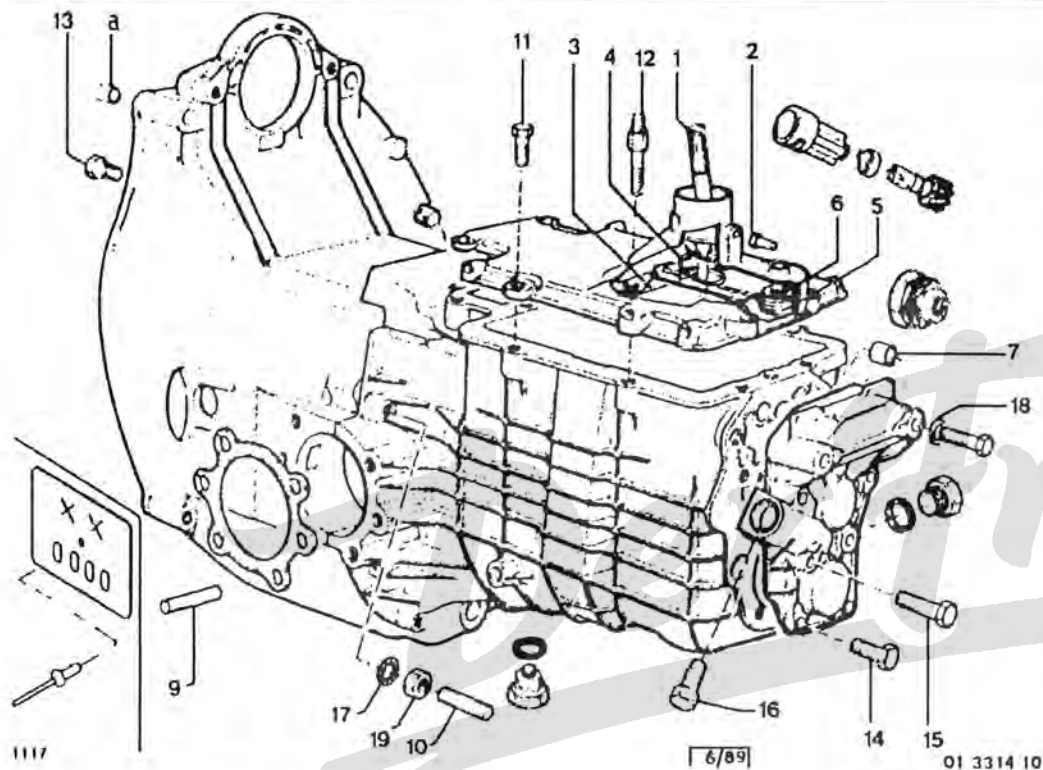

- NOTA: LES PIECES NON REPEREES VOIR CHAPITRES 01-3303-10  
 01-3323-10

01	75 524 525	01 RMP AM33103	02/80 ▶	LEVIER HEBEL LEVER PALANCA LEVA
02	AM 334 100	01 LON 15-DIAM 4		DOIGT MECANIQUE ZAPFEN MECHANL FINGER DEDO MECANICA LEVA

03	AM 334 95 A	01	DIAM 7,8	GUIDE RESSORT FUEHRUNG SPRING GUIDE GUIA RESORTE GUIDA MOLLA
04	AM 334 97	01		RESSORT FEDER LEVER SPRING RESORTE MOLLA
05	AM 334 103 A	01		-
06	AM 334 23	01	DIAM 7	CUVETTE STUETZGEHAEUSE SPRING RETAINER PLATILLO MUELLE SCODELLINO
07	5 402 249	02	DIAM 10,5X20X29	ENTRETOISE ABSTANDSSTUECK SPACER JUEGO DISTANCIA DISTANZIALE
08	AZ 331 99	03	10X14X27,5	BAGUE CENTRAGE ZENTRIERRING CENTRING BUSH CASQUILLO CENT. BOCCOLA CENTRAG
09	26 165 009	12	DIAM 9X8X1,25-43F17	GOUJON STEBBOLZEN STUD ESPARRAGO PERNO
10	26 165 019	04	DIAM 10X1,50-57,5F16	-
11	79 03 201 060	02	TH 10X1,50-LON 100	VIS TH SCHRAUBE CAPSCREW TORNILLO TH VITE
	79 03 101 777	04	TH 7X1,00-32	-
12	5 438 849	04	COL 7X1,00-51	VIS COLONNETTE STUETZSCHRAUBE SCREW COLUMN TORNILLO COLUMN VITE COLONNETTA

15/02/91  
 1117 01-3314-10  
 PAGE : 2  
 D12 ↓

**CARTER BOITE DE VITESSES - FIXATION**  
 GETRIEBEGEHAEUSE - BEFESTIGUNG  
 GEARBOX CASING - FASTENING  
 CARCASA DE LA CAJA DE CAMBIO-FIJACION  
 CORPO DEL CAMBIO DI VELOCITA-FISSAGGIO

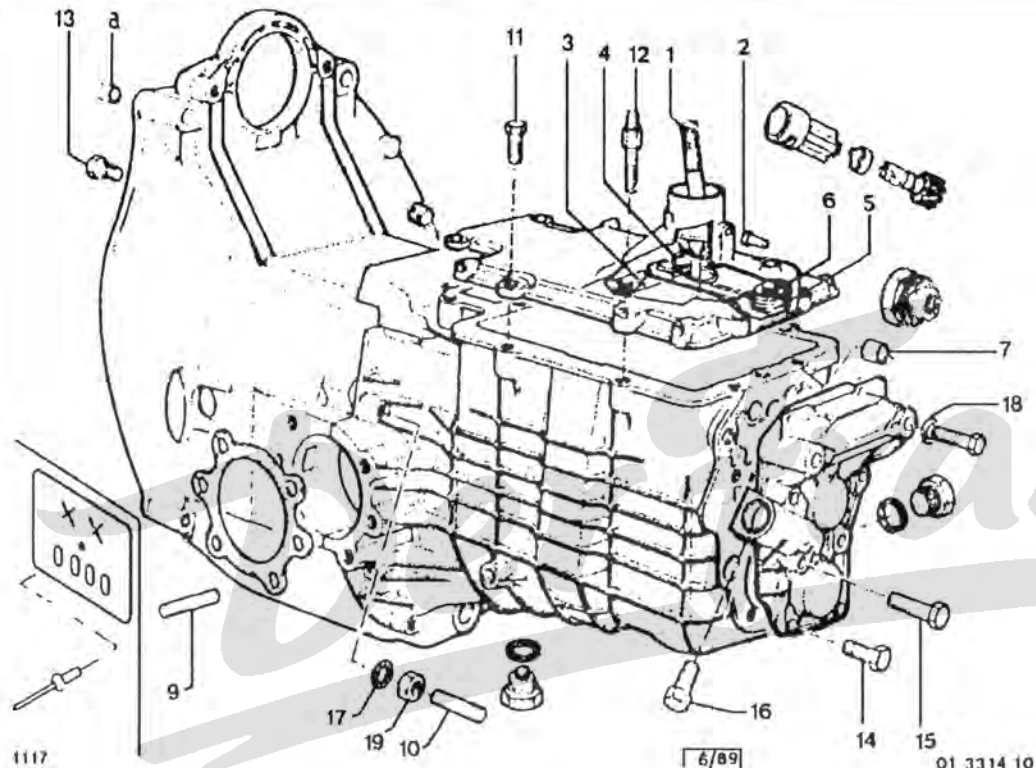

01 3314 10  
 Z3314100

13	95 623 773	04	TH7X1,00-25	VIS SCHRAUBE SCREW TORNILLO VITE
14	95 623 739	04	TH 7X100-28	VIS TH SCHRAUBE CAPSCREW TORNILLO TH VITE
15	79 03 101 760	05	8X35	-

16	79 03 101 776	01	TH 7X1,00-50	VIS TH SCHRAUBE CAPSCREW TORNILLO TH VITE
17	79 03 055 019	01	DIAM 10	RONDELLE GROWER GROWERSCHEIBE SPRING WASHER ARANDELA RONDELLA GROWER
18	79 03 056 017	02	DIAM 10,5X16,8	-
19	79 03 032 252 RP 7903232018	02	H . 10X1,50	ECROU HEXAGONAL SECHSKANTMUTTER HEXAGONAL NUT TUERCA DADO ESAGONALE

15/02/91  
 1117 01-3323-10  
 PAGE : 1  
 D11 ↓

**COMMANDE DE COMPTEUR**  
 GESCHWINDIGKEITSMESSERANTRIEB  
 SPEEDOMETER DRIVE  
 MANDO CUENTAKILOMETROS  
 COMANDO CONTACHILOMETRI

03

5 411 679

01 DIAM INT 12 - H 6,2 ▶ 1695

CUVETTE  
 FEDERTELLER  
 SPRING RETAINER  
 PLATILLO MUELLE  
 SCODELLINO

04

95 558 232

01 LON 47 "NYLON"  
 RMP AM3812

1696 ▶

PRISE DE FORCE  
 KRAFTABNAHME  
 POWER TAKE-OFF  
 CABLE CUENTAKM.  
 PRESA CONTACTM

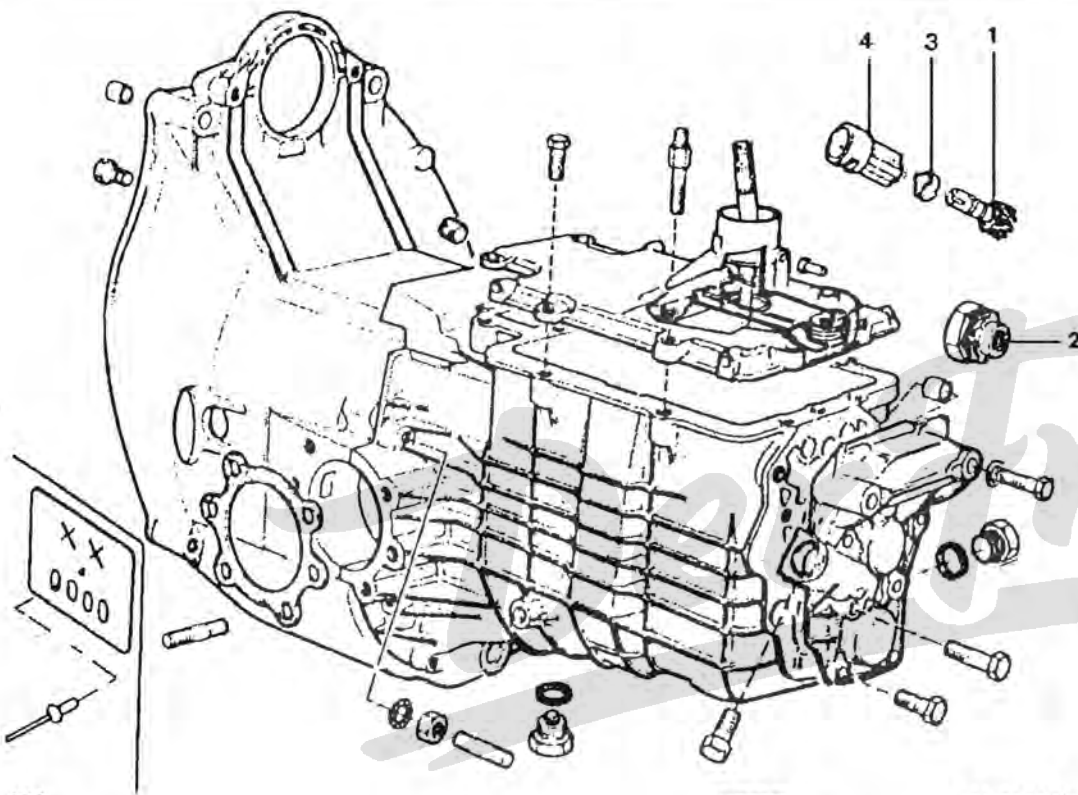

1117  
 01-3323-10  
 Z3323100

NOTA: LES PIECES NON REPEREES VOIR CHAPITRES 01-3303-10  
 01-3314-10-

1	AM 381 1 B	01 16 DENT	VIS TACHYMETRE TACHOSCHNECKE TACHOMETR SCREW CORONA C KM/TS VITE
2	AT 381 3 A	01 DIAM 16X1,50 4 FILETS	



15/02/91  
 1117 01-3342-10  
 PAGE : 1  
 D10 ↓

**ARBRE PRIMAIRE-BALADEUR**  
 PRIMAERWELLE-SHIEBEMUFFE  
 PRIMARY SHAFT-SLIDING SLEEVE  
 ARBOL PRIMARIO - DESPLAZABLE  
 ALBERO PRIMARIO-SCORREVOLE

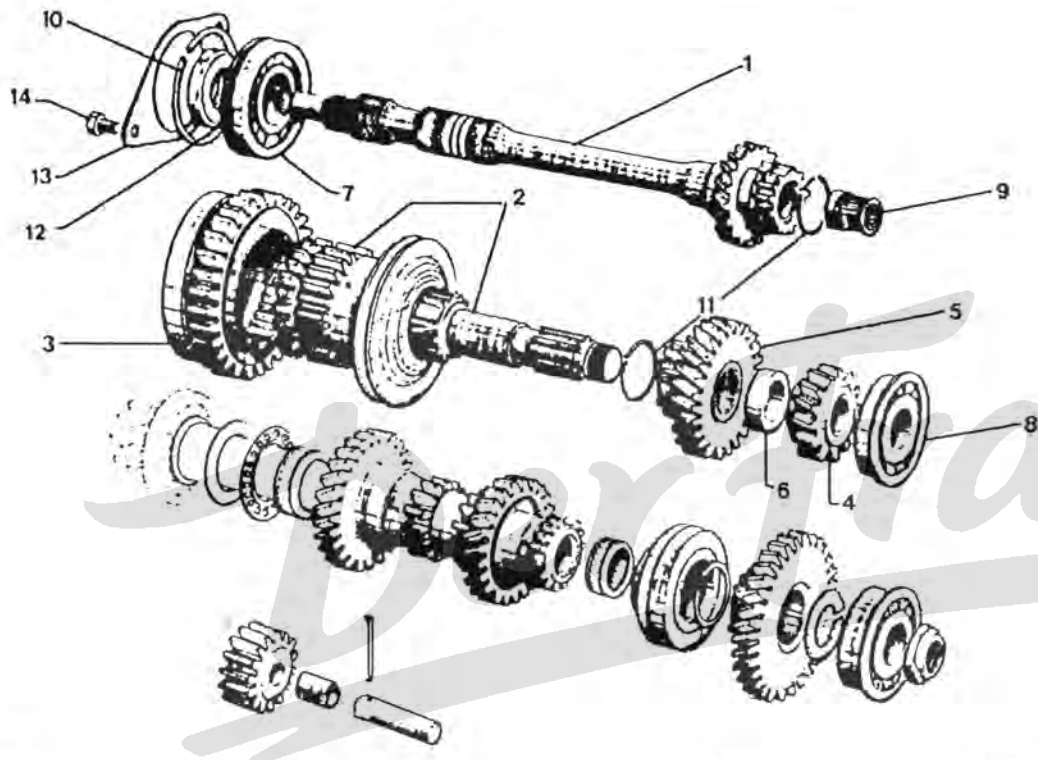

1117

[6/69]

01.3342.10

Z3342100

- NOTA: LES PIECES NON REPEREES VOIR CHAPITRE 01-3344-10

01	<b>AM 332 1 E</b>	01 19 DENT EMBCEN	1918 ▶ 2828	<b>ARBRE D'ENTREE</b> EINGANGSWELLE INPUT SHAFT ARBOL DE ENTRA, ALBERO DIENTRAT
	<b>95 563 550</b>	01 19 DENT EMBNOR	1918 ▶ -	

02	96 995 658	01		<b>ARBRE PRIMAIRE</b> PRIMAERWELLE PRIMARY SHAFT ARBOL PRIMARIO ALBERO PRIMARIO
03	<b>AM 335 04 B</b>	01 1E		<b>PIGNON BALADEUR</b> RITZEL PINION PINON DESPLAZA INGRANAG SCOR
04	<b>AYB 333 3</b>	01 14 DENT		<b>PIGNON REDUCT.</b> RITZEL REDUCER PINION PINON REDUCTOR PIGNONE
05	<b>AM 333 2 A</b>	01 26 DENT-2E		<b>PIGNON ARBRE</b> RITZEL PINION PINON ARBOL PIGNONE
06	<b>5 476 438</b>	01 20X28X12,4		<b>ENTRETOISE</b> ABSTANDSSTUECK SHAFT SPACER DISTANCIADOR Distanziale
07	<b>95 496 767</b>	01 DIAM 25X52X15		<b>ROULEMENT</b> LAGER BEARING RODAMIENTO CUSCINETTO
08	<b>79 03 090 276</b>	01 20X52X57X15		-
09	<b>ZC 9620 374 U</b>	01 15X20X27		-
10	<b>ZC 9620 542 U</b>	01 49X55,5X1,35		<b>SEGMENT D'ARRET</b> HALTERING BEARNG SNAP RING ANILLO RETENC. SEGMENTO FERMO
11	<b>A 335 90 A</b>	02 2E-3E-DIAM EXT 29,5		-
12	<b>AZ 332 4</b>	01 HE 22X1,50-E 10,5		<b>ÉCROU FIX ARBRE</b> BEF. MUTTER WELL SHAFT FIX NUT TUERCA DADO FISS. ALBER.

.../...

15/02/91  
 1117 02-1419-10  
 PAGE : 2  
 C05 ↑

COMMANDE D'ACCELERATEUR  
 GASPEDALBETAETIGUNG  
 ACCELERATOR CONTROL  
 MANDO DE ACELERADOR  
 COMANDO DEL ACCELERATORE

54

75 514 352

01 LON 992  
 -CAD

**XT**

CABLE DE CDE  
 BET.-ZUG  
 CONTROL CABLE  
 CABLE ACELERAD.  
 CAVO DI COMANDO

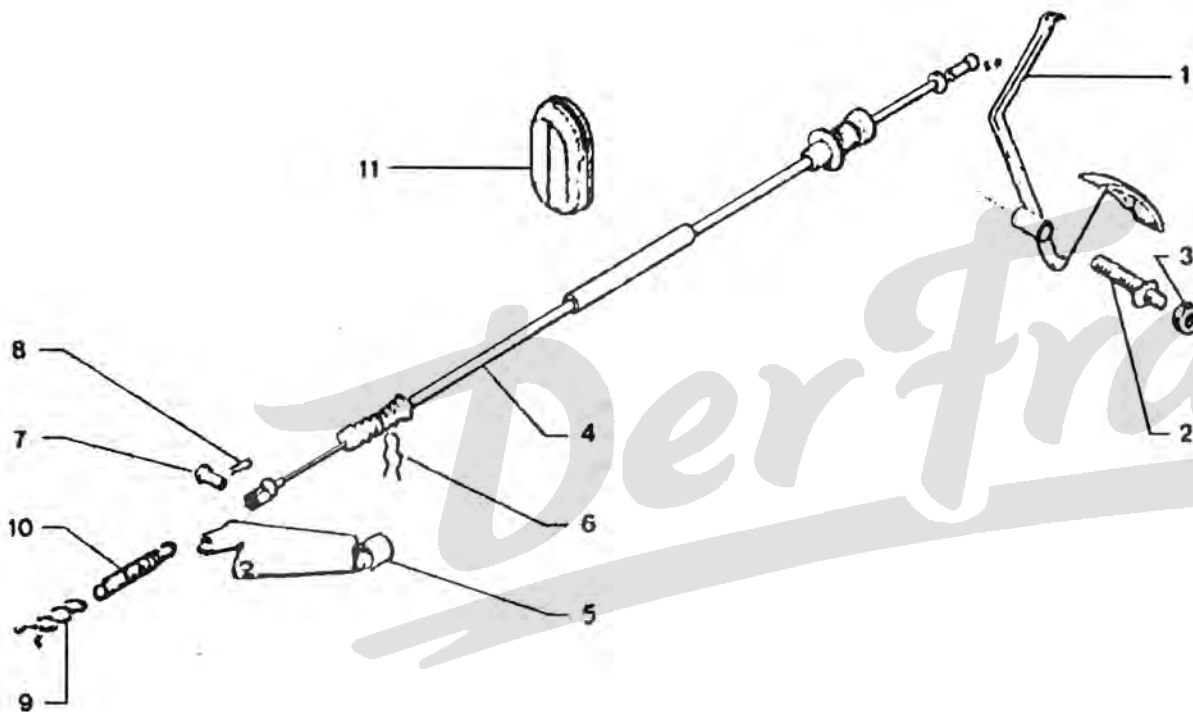

1114

2-142-10

Z1419100

1 5 507 094

01 CC - 76,2X35,2  
 SUR TABLIER

ETANCHEITE  
 ABDICHTUNG  
 SEALING  
 ESTANQUEIDAD  
 TENUTA

15/02/91  
 1117 02-1419-20  
 PAGE : 1  
 C06 ↑

**COMMANDE D'ACCELERATEUR**  
 GASPEDALBETAETIGUNG  
 ACCELERATOR CONTROL  
 MANDO DE ACELERADOR  
 COMANDO DEL ACCELERATORE

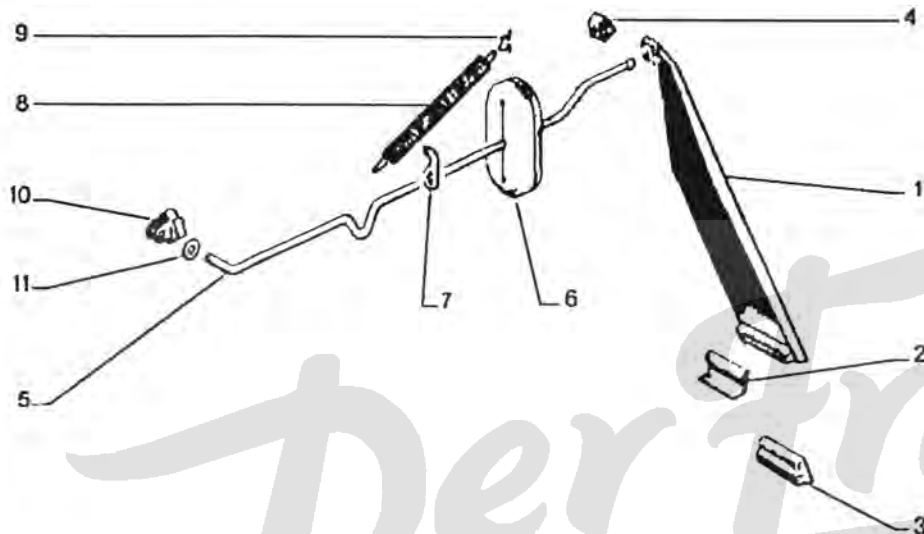

1114

2-142-20

Z1419200

(D)  
 ► 11/79

- NOTA: MONTAGE CARBURATEUR MONO-CORPS

01	AZ 142 301 A	01 AVEC BUTEE	PEDALE GASPEDAL ACCELERAT PEDAL PEDAL PEDALE
02	AZ 142 95	01 DIAM 8,5	SUPPORT PEDALE PEDALHALTER PEDAL BRACKET SOP.PEDAL ACELE SUPPORTO

03	AZ 142 107	01 LON 43 << NYLON >>	PALIER LAGER BEARING CASQUILLO CUSCINETTO
04	A 142 83	01	BUTEE CAOUTCHOU ANSCHLAG RUBBER BUFFER TOPE GOMA REGGISPINTA
05	AZ 142 387 A	01 LON 328	TIGE DE CDE BETAETIG.STANGE CONTROL ROD VARILLA MANDO ASTA COMANDO
06	AY 142 90	01 CC-35X76	ETANCHEITE ABDICHTUNG SEALING ESTANQUEIDAD TENUTA
07	5 420 540	01	CROCHET HAKEN HOOK GANCHO GANCIO
08	75 514 904	01 DIAM 12	RESSORT RUCKZUGFEDER RETURN SPRING MUELLE MOLLA RICHIAMO
09	75 420 121	01 EMBNOR	AGRAFE KLAMMER CLIP GRAPA AGRAFE
10	5 420 120	01	-
11	75 420 125	01 3X10X3	RONDELLE FLUTRE FILZSCHEIBE FELT WASHER ARANDELA RONDELLA FELTRO

15/02/91  
 1117 01-3342-10  
 PAGE:2  
 D9 ↓

ARBRE PRIMAIRE-BALADEUR  
 PRIMAERWELLE-SHIEBEMUFFE  
 PRIMARY SHAFT-SLIDING SLEEVE  
 ARBOL PRIMARIO - DESPLAZABLE  
 ALBERO PRIMARIO-SCORREVOLE

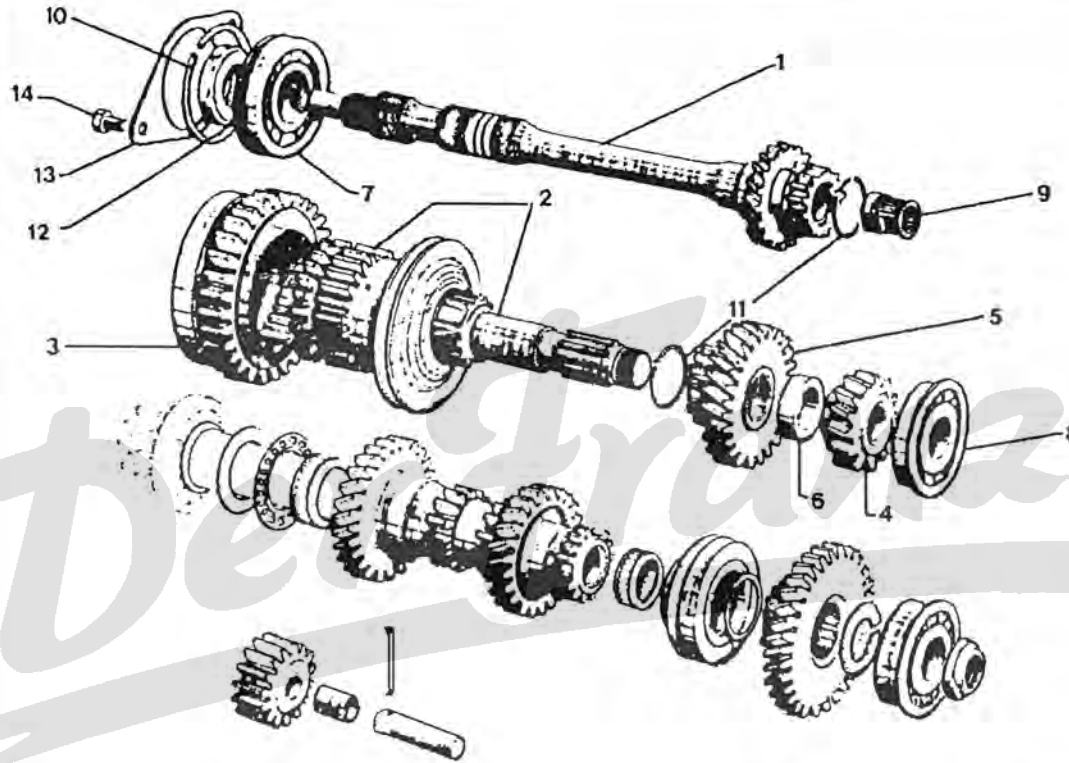

1117

[6/89]

01.3342.10

Z3342100

13	A 332 96	01	DIAM 46-E 3.5	BRIDE MAINTIEN HALTESTEG FLANGE BRIDA SUJECION STAFFA TENUTA
14	79 03 101 755	02	DIAM 7X1 00-22	VIS TH SCHRAUBE CAPSCREW TORNILLO TH VITE

15/02/91  
1117 01-3344-10  
PAGE : 1  
D08 ↓

**ARBRE SECONDAIRE - PIGNONS - SYNCHROS**  
SEKUNDAERWELLE - ZAHNRAEDER - SYNCHRONE  
SECONDARY SHAFT - GEARS - SYNCHRONIZERS  
ARBOL SECUNDARIO  
ALBERO SECONDARIO

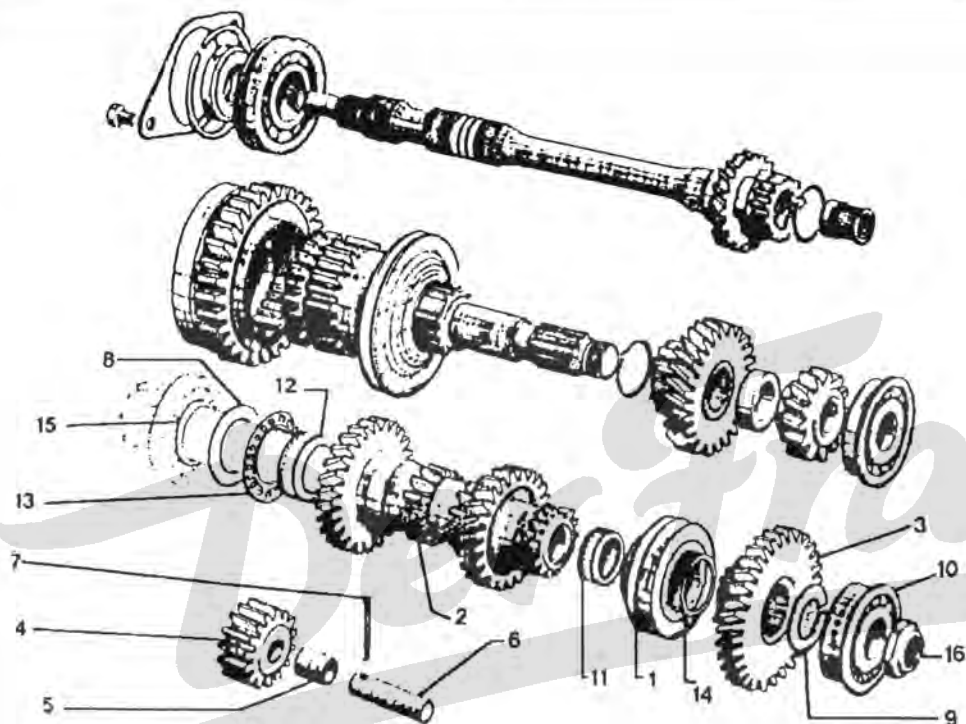

[B/B9]

01.3344.10

Z334410J

- NOTA: LES PICES NON REPEREES VOIR CHAPITRE 01-3342-10

01	96 995 659	01 4E	PIGNON BALADEUR RITZEL PINION PINON DESPLAZA INGRANAG SCOR
02	95 604 396	01 14X14X23X25 DENT	ARBRE INTM WELLE COUNTERSHAFT ARBOL INTERMED. ALBERO
	AM 333 5 C	01 14X14X23X27 DENT	-

03	AYB 333 4	01 25 DENT	PIGNON RITZEL RETURN PINION PINON INGRANAGGIO
04	AZ 333 7	01 15 DENT M AR	-
05	AZ 333 92	01 12X14,5X24	BAGUE DE PIGNON RING F.RITZEL PINION RING CASQUILLO PINON BOCCOLA PIGNONE
06	AZ 332 2	01 12X48,5	AXE DE RENVOI UMLENKACHSE RETURN SHAFT EJE REENVIO PERNO RINVIO
07	AZ 332 48	01 DIAM 5-LON 35	GOUPILLE D'AXE ACHSSTIFT SPINDLE PIN PASADOR DE EJE COPPIGLIA PERNO
08	AM 333 220	99 DIAM 29,5X43-E 1,64	RONDELLE SCHEIBE WASHER ARANDELA RONDELLA
	AM 333 221	99 DIAM 29,5X43-E 1,73	-
	AM 333 222	99 DIAM 29,5X43-E 1,82	-
	AM 333 223	99 DIAM 29,5X43-E 1,91	-
	AM 333 224	99 DIAM 29,5X43-E 2,00	-
	AM 333 225	99 DIAM 29,5X43-E 1,55	-
	AM 333 226	99 DIAM 29,5X43-E 1,46	-
	AM 333 227	99 DIAM 29,5X43-E 1,37	-
09	AM 344 300	99 DIAM 20X32-E 2,01	CALE DE REGLAGE EINSTELLBEILAGE ADJUSTMENT SHIM CALA REGLAJE SPESSORE DI REG
	AM 344 301	99 DIAM 20X32-E 2,05	-
	AM 344 302	99 DIAM 20X32-E 2,09	-

.../...

**ARBRE SECONDAIRE - PIGNONS - SYNCHROS**  
**SEKUNDAERWELLE - ZAHNRAEDER - SYNCHRONE**  
**SECONDARY SHAFT - GEARS - SYNCHRONIZERS**  
**ARBOL SECUNDARIO**  
**ALBERO SECONDARIO**

09

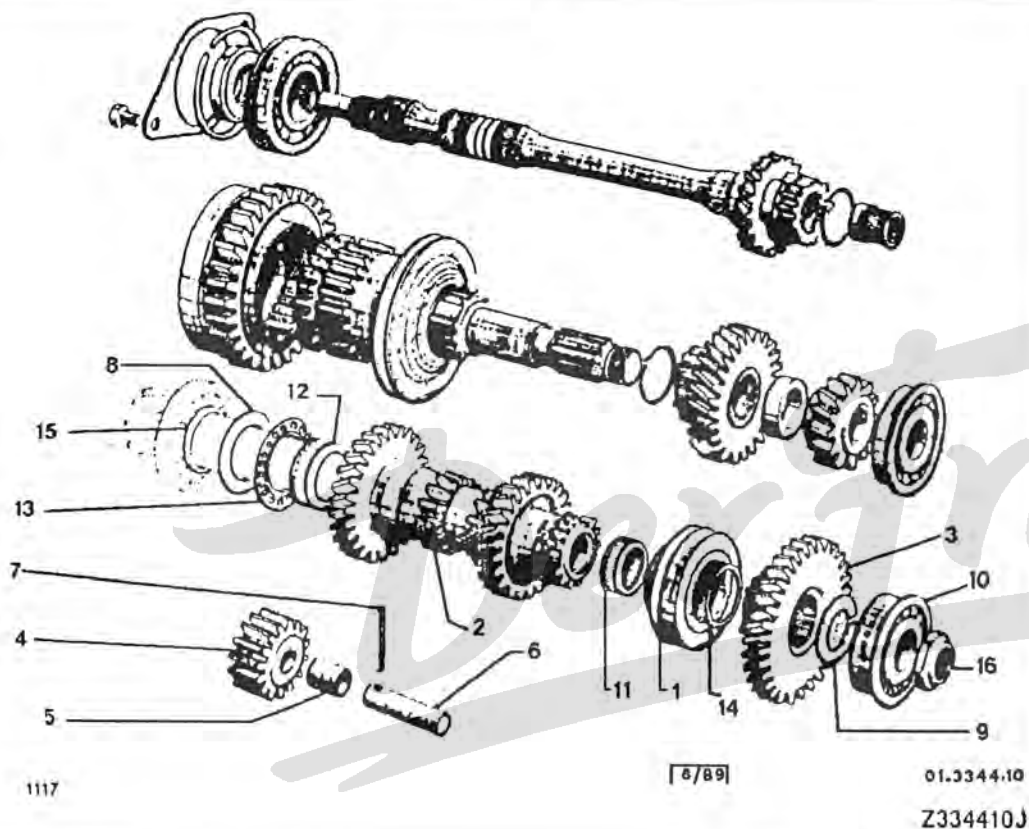

09	<b>AM 344 303</b>	99	DIAM 20X32-E 2,13	CALE DE REGLAGE EINSTELLBEILAGE ADJUSTMENT SHIM CALA REGLAJE SPESSORE DI REG
	<b>AM 344 304</b>	99	DIAM 20X32-E 2,17	-
	<b>AM 344 305</b>	99	DIAM 20X32-E 2,21	-
	<b>AM 344 306</b>	99	DIAM 20X32-E 2,25	-
	<b>AM 344 307</b>	99	DIAM 20X32-E 2,29	-

<b>AM 344 308</b>	99	DIAM 20X32-E 2,33	CALE DE REGLAGE EINSTELLBEILAGE ADJUSTMENT SHIM CALA REGLAJE SPESSORE DI REG
<b>AM 344 309</b>	99	DIAM 20X32-E 2,37	-
<b>AM 344 310</b>	99	DIAM 20X32-E 2,41	-
<b>AM 344 311</b>	99	DIAM 20X32-E 2,45	-
<b>AM 344 312</b>	99	DIAM 20X32-E 2,49	-
<b>AM 344 313</b>	99	DIAM 20X32-E 2,53	-
<b>AM 344 314</b>	99	DIAM 20X32-E 2,57	-
<b>AM 344 315</b>	99	DIAM 20X32-E 2,61	-
<b>AM 344 316</b>	99	DIAM 20X32-E 2,65	-
<b>AM 344 317</b>	99	DIAM 20X32-E 2,69	-
<b>AM 344 318</b>	99	DIAM 20X32-E 2,73	-
<b>AM 344 319</b>	99	DIAM 20X32-E 2,77	-
<b>AM 344 320</b>	99	DIAM 20X32-E 2,81	-
<b>AM 344 321</b>	99	DIAM 20X32-E 2,85	-
<b>AM 344 322</b>	99	DIAM 20X32-E 2,89	-
<b>AM 344 323</b>	99	DIAM 20X32-E 2,93	-
<b>AM 344 324</b>	99	DIAM 20X32-E 2,07	-
<b>AM 344 325</b>	99	DIAM 20X32-E 3,01	-
<b>AM 344 326</b>	99	DIAM 20X32-E 3,05	-
<b>AM 344 327</b>	99	DIAM 20X32-E 3,09	-
<b>AM 344 328</b>	99	DIAM 20X32-E 3,13	-
<b>AM 344 329</b>	99	DIAM 20X32-E 3,17	-
<b>AM 344 330</b>	99	DIAM 20X32-E 3,21	-

15/02/91  
1117 01-3344-10  
PAGE : 3  
D06 ↓

**ARBRE SECONDAIRE - PIGNONS - SYNCHROS**  
**SEKUNDAERWELLE - ZAHNRAEDER - SYNCHRONE**  
**SECONDARY SHAFT - GEARS - SYNCHRONIZERS**  
**ARBOL SECUNDARIO**  
**ALBERO SECONDARIO**

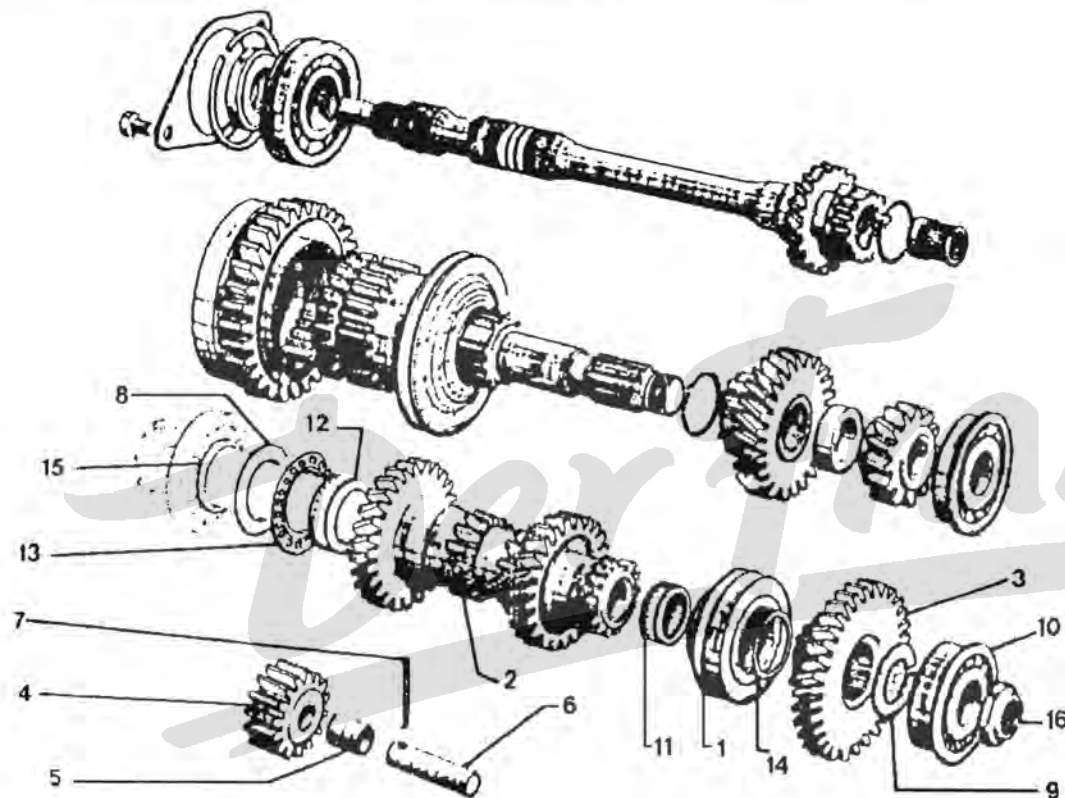

1117

[ 6/89 ]

01.3344.10

Z334410J

13	26 202 299	01	19,5X45,25X2,02	BUTEE AIGUILLES DRUCKNADELLAGER NEEDLE BEARING CASQUILLO CUSCINETTO
14	AM 335 90	01	4E-DIAM EXT 31	SEGMENT D'ARRET HALTERING BEARG SNAP RING ANILLO RETENC. SEGMENTO FERMO
15	AM 344 96 A	01	27,7X34,1X2,5	
16	A 344 5 A	01	HE 20X1,50	ECROU MUTTER NUT TUERCA DADO
10	95 572 590	01	20X52X57,15X22	ROULEMENT LAGER BEARING RODAMIENTO CUSCINETTO
11	ZC 9620 275 U	01	19X20X27	-
12	ZC 9620 361 U	01	29,5X33,5X18,2	-

**LEVIERS - AXES - FOURCHETTES**  
 HEBEL - ACHSEN - GABELN  
 LEVERS - SHAFTS - FORKS  
 PALANCAS-EJES-HOROUILLAS  
 LEVAS-PERNI-FORCELLE

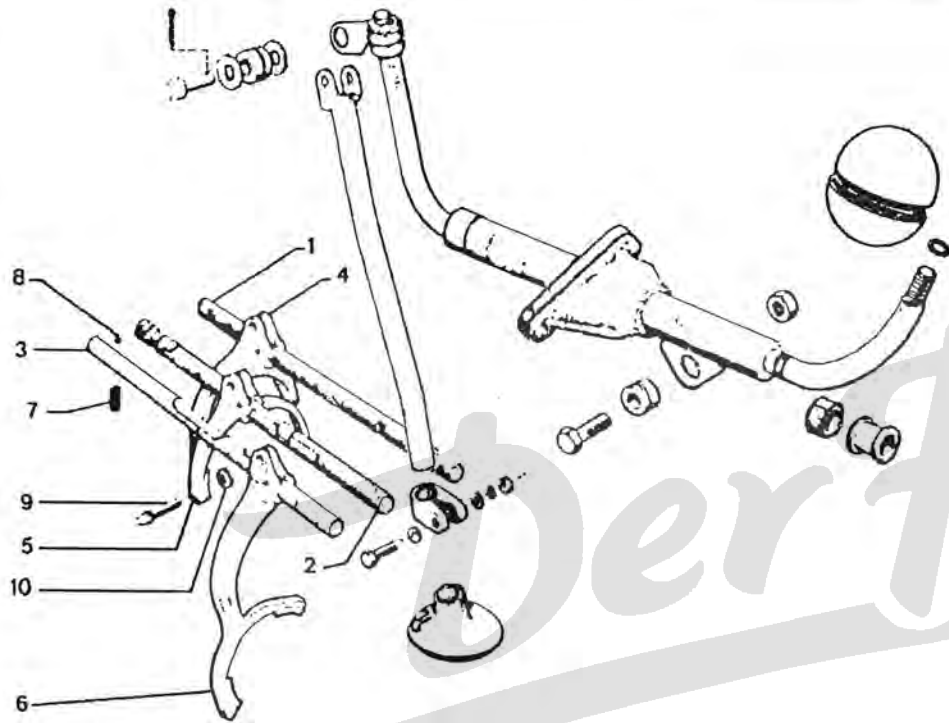

1117

[8/89]

01.3355.10

Z3355100

- NOTA: LES PIECES NON REPEREES VOIR CHAPITRE 01-3358-10

04	AM 334 6	01	1E -M AR	FOURCHETTE KLAMMER FORK HOROUILLA FORCELLA
05	AM 334 7	01	2E-3E	-
06	AM 334 8 A	01	4E	-
07	AM 334 11	03	14 SPIR DIAM EXT 7,5	RESSORT FEDER BALL SPRING MUELLE MOLLA
08	24 113 009	05	DIAM 7,5	BILLE VERROU KUGEL LOCKING BALL BOLA SFERA
09	26 228 109	03	7X18	VIS BUTEE D'AXE SCHRAUBE FORK STOP SCREW TORNILLO TOPE VITE
10	26 240 229	02	DIAM 6,5X14,2	CALE DE REGLAGE EINSTELLBEILAGE ADJUSTMENT SHIM CALA REGLAJE SPESSORE REGOL.

01	AM 334 1	01	1E-M AR -LON 220	AXE DE CDE BETAETIG.-ACHSE CONTROL SHAFT EJE DE MANDO PERNO CDO
02	AM 334 9	01	2E-3E -LON 220	-
03	AM 334 10	01	4E -LON 220	-



15/02/91  
1117 01-3358-10  
PAGE : 1  
D04 ↓

**COMMANDE DE VITESSES-COTE HABITACLE**  
GANGSCHALTUNG INNENRAUMSEITE  
GEAR-CHANGE CONTROL-BINACLE SIDE  
MANDO DE VELOCIDADES-LADO BITACORA  
COMANDO DELLMARCE - LATO ABITACOLO

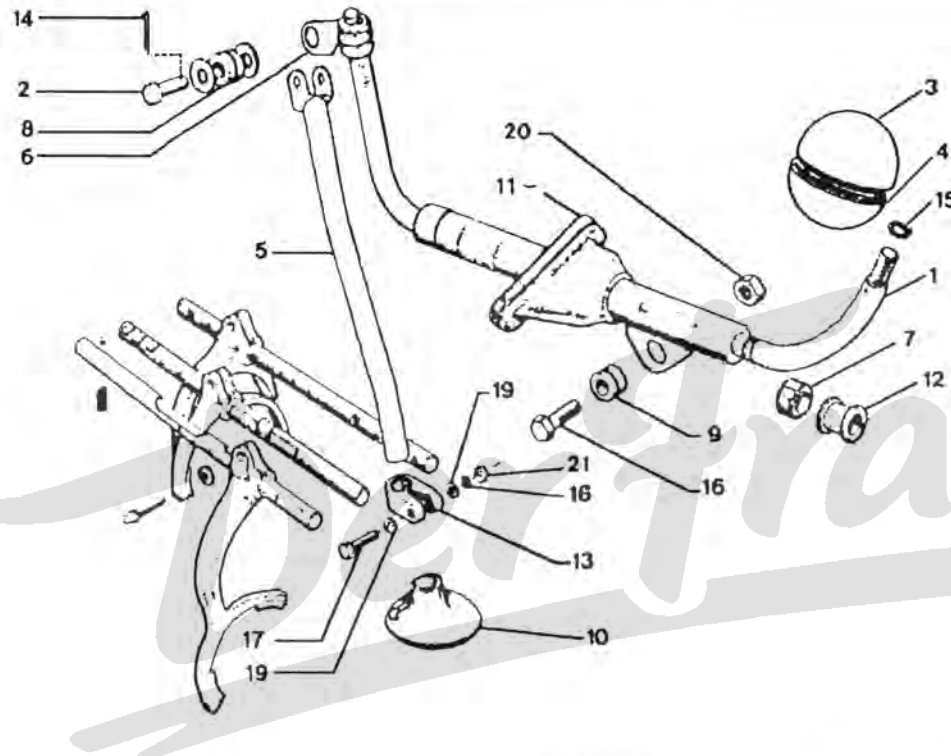

1117

8/89

01-3358-10  
Z3358100

- NOTA: LES PIECES NON REPEREES VOIR CHAPITRE 01-3355-10

01	96 995 313	01	LEVIER DE CDE HEBEL CONTROL LEVER PALANCA MANDO LEVA	03	AY 334 460 A	01	SUP	DEMI-BOULE HALBKUGEL LEVER HALF-KNOB SEMI POMO SEMISFERA LEVA
02	5 417 536	01	DIAM 6-LON 20	04	AY 334 461 A	01	INF	-
				05	AK 334 3 A	01	DIAM INT 10,25X235	LEVIER HEBEL SELECTION LEVER PALANCA SELECC. LEVA
				06	AY 334 51	01		BIELLETTE PASSA GESTAENGE F SCH GEARSHIFT LINK BIELETA PASO BIELETTA
				07	A 334 57	02	CC-13,7X20X12	BAGUE DE LEVIER HUELSE AN HEBEL LEVER RING CASQUILLO BOCCOLA LEVA
				08	5 419 946	02	6X16X12,5 CAOUTCHOUC	-
				09	AY 334 73	02	61X17X5,87 *NYLON*	-
				10	AM 334 62	01	CC-DIAM INT 8,5-34	PROTECTEUR SCHUTZ LEVER PROTECTOR PROTECTOR PROTEZIONE
				11	AZ 334 80	01	CC-32X72	JOINT DICHTUNG LEVER GASKET JUNTA GUARNIZIONE
				12	A 334 81 A	02	12X14X18X4,2	COUSSINET LAGERBUCHSE LEVER BEARING COJINETE CUSCINETTO
				13	AM 334 106	01	DIAM INT 14	COLLIER SCHELLE ADJUST COLLAR ABRAZADERA COLLARE

.../...

15/02/91  
 1117 01-3358-10  
 PAGE : 2  
 D03 ↓

**COMMANDE DE VITESSES-COTE HABITACLE**  
 GANGSCHALTUNG INNENRAUMSEITE  
 GEAR-CHANGE CONTROL-BINACLE SIDE  
 MANDO DE VELOCIDADES-LADO BITACORA  
 COMANDO DELLMARCE - LATO ABITACOLO

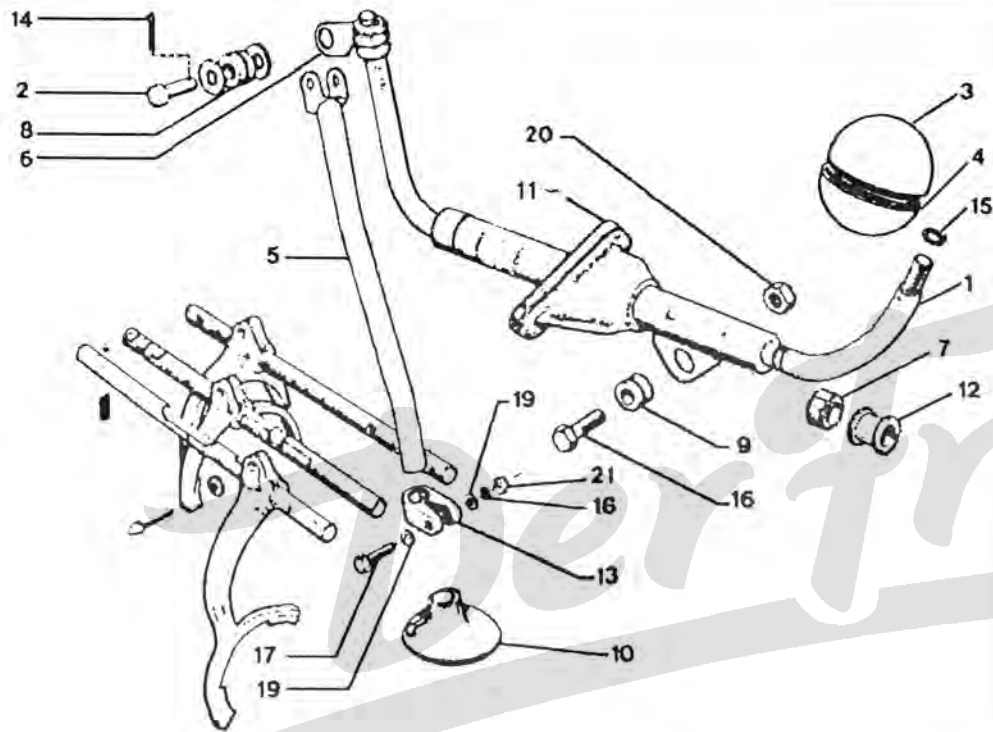

1117

15/91

01-3358-10  
 Z3358100

16	23 686 009	01	TH-6X1,00-28	VIS TH SCHRAUBE CAPSCREW TORNILLO TH VITE
17	79 03 101 806	01	TH 7X1,00-30	-
18	79 03 056 012	05	CR 7,3X12	RONDELLE GROWER GROWERSCHEIBE SPRING WASHER ARANDELA RONDELLA GROWER
19	79 03 053 390	02	DIAM 7X14X1,5	RONDELLE PLATE FLACHSCHEIBE PLAIN WASHER ARANDELA PLANA RONDELLA PIA'TA
20	79 03 234 016	01	HEF 6X1,00	ECROU MUTTER PIPE NUT TUERCA DADO
21	79 03 032 036	01	HE 7X1,00-5,5	-
<b>XT</b>				
51	96 995 269	01	ENS CAD	LEVIER DE CDE HEBEL CONTROL LEVER PALANCA MANDO LEVA

14	79 03 066 999	01	DIAM 2-LON-20	EPINGLE SPANGE BRAKE PLATE PIN GRUPILLA SPILLO
15	AY 334 89	01	10X13,5X1	RONDELLE SCHEIBE WASHER ARANDELA RONDELLA

15/02/91  
 1117 01-3430-10  
 PAGE : 1  
 D02 ↓

**DIFFERENTIEL**  
 DIFFERENTIALGETRIEBE  
 DIFFERENTIAL  
 DIFERENCIAL  
 DIFFERENZIALE

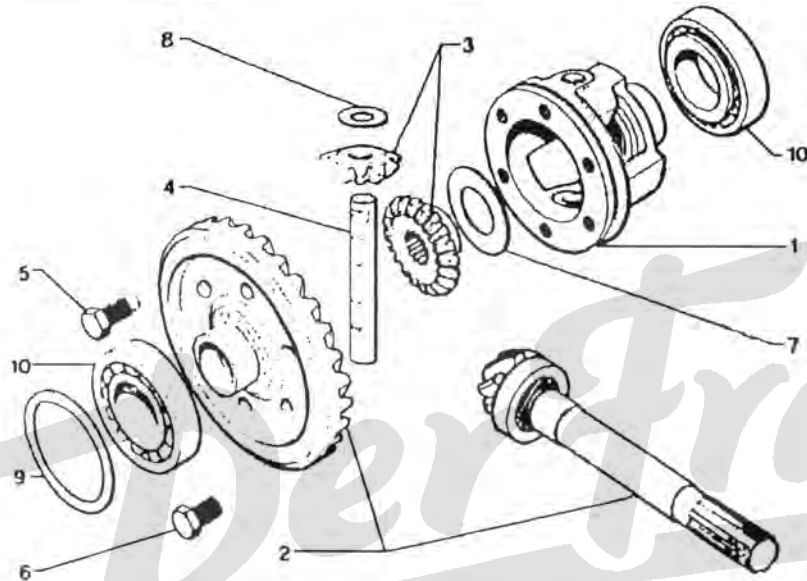

1117

105/841

1-343-10

Z3430100

01	* AZ 343 1	01	6 DIAM 10X1,25	BOITIER GEHAEUSE DIFF HOUSING CAJA PORTASATEL SCATOLA
02	* AY 344 01	01	C 8X33	SECTEUR CRANTE ZAHNRAD LOCKING SECTION SECTOR SETTORE DENTATO

03	* 75 511 563	01	ENS	ENS PLAN + SATEL. PLANET + SATELLIT GEAR SET PLANET + SATELIT PLANET + SATELLIT
04	* AM 343 4 A	01	DIAM 13 LON 94	AXE DES PIGNONS ACHSE F.RITZEL GEARS SPINDLE EJE SATELITES PERNO PIGNONI
05	* AZ 343 5	01	TH 10X28	VIS SCHRAUBE RING GEAR SCREW TORNILLO VITE FISS.
06	75 527 576	05	TH10X21,5	-
07	* AM 343 7	99	28,5X52-E 1,35	COUPELLE TELLER FRICTION CUP COPELA SCODELLINO
	* AM 343 7 B	99	E 1,47	-
	* AM 343 7 D	99	E 1,59	-
	* AM 343 7 F	99	E 1,71	-
08	* AM 343 8	99	13X28-E 1,47	RONDELLE SCHEIBE FRICTION WASHER ARANDELA RONDELLA
	* AM 343 8 B	99	E 1,61	-
	* AM 343 8 D	99	E 1,75	-
	* AM 343 8 F	99	E 1,89	-
	AM 343 8 H	99	E 2,03	-
	* AM 343 8 J	99	E 2,17	-
	* AM 343 8 L	99	E 2,31	-
09	* A 343 98	99	62X72-E 0,05	-
	* A 343 98 A	99	E 0,10	-
	* A 343 98 B	99	E 0,20	-

.../...

15/02/91  
 1117 01-3430-10  
 PAGE : 1  
 D01 ↓

**DIFFERENTIEL**  
 DIFFERENTIALGETRIEBE  
 DIFFERENTIAL  
 DIFERENCIAL  
 DIFFERENZIALE

10 26 203 529 02 DIAM 35X72X18  
**ROULEMENT**  
 LAGER  
 DIFFER. BEARING  
 RODAMIENTO  
 CUSCINETTO

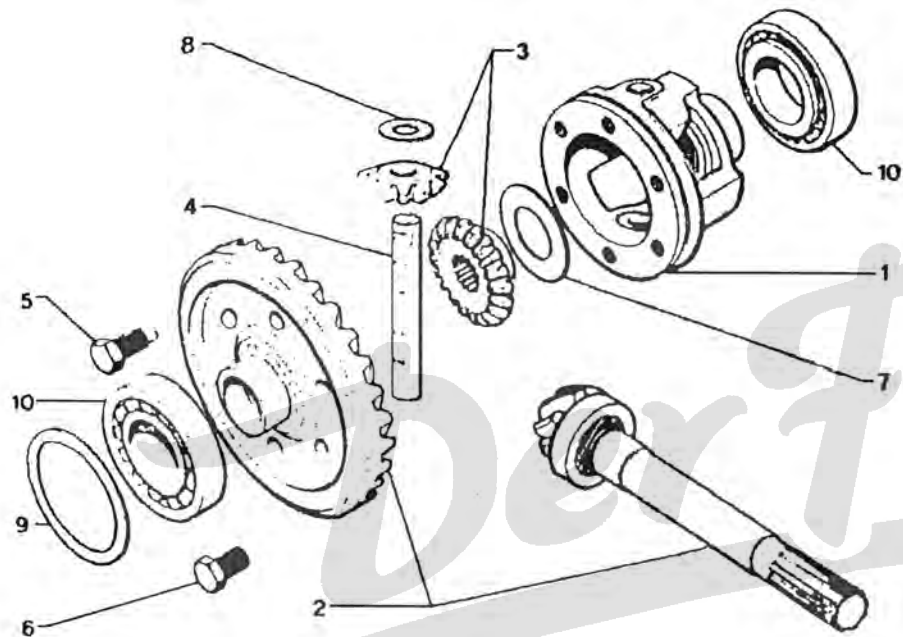

1117 [05/84] 1.343.10  
 Z3430100

09	* A 343 98 C	99 E,050	RONDELLE SCHEIBE FRICTION WASHER ARANDELA RONDELLA
	A 343 98 D	99 E 1,00	-
	* AZ 343 198 A	99 E 0,12	-

IMERO	SOUS-GROUPE	REP	NUMERO	SOUS-GROUPE	REP	NUMERO	SOUS-GROUPE	REP	NUMERO	SOUS-GROUPE	REP
102 249	01-3314-10	07	26 205 599	01-1212-10	20	75 516 383		17	95 604 396	01-3344-10	02
111 679	01-3323-10	03	26 212 079	01-1142-10	08	75 516 387		18	95 605 456	01-1212-10	01
112 403	01-0010-10	51	26 213 659	01-2221-10	16	75 516 389		20	95 615 620	01-1120-10	51
		01	26 214 459		16	75 516 390		18	95 615 621		51
117 536	01-3358-10	02	26 228 109	01-3355-10	09	75 516 392		21	95 616 725	01-0010-10	51
119 946		08	26 228 129	01-1120-10	25	75 516 393		22	95 616 726	01-1140-10	52
120 190	01-1212-10	10	26 231 549	01-2250-10	15	75 516 394		26	95 616 727	01-1120-10	51
124 930		02	26 240 229	01-3355-10	10	75 516 398		03	95 616 728		51
124 931		02	75 403 834	01-2250-10	10	75 516 400	01-2250-10	12	95 623 739	01-3314-10	14
126 572	01-1140-10	02	75 411 382	01-3303-10	05	75 516 401		09	95 623 773		13
127 485	01-3300-10	01	75 411 410	01-2250-10	07	75 516 403	01-2221-10	02		01-2250-10	24
127 960	01-1140-10	01	75 411 411		11	75 516 409		03	95 640 573	01-3300-10	51
133 578	01-1120-10	04	75 412 011	01-1120-10	14	75 516 410		04	95 650 887	01-1212-10	21
138 849	01-3314-10	12	75 412 014		30	75 516 411		05	96 995 255	01-3303-10	53
140 576	01-2250-10	01	75 412 173	01-2250-10	18	75 516 412		15	96 995 258	01-1212-10	15
157 475	01-1120-10	07	75 412 174		22	75 516 414		08	96 995 269	01-3358-10	51
157 476		06	75 415 425		23	75 516 416		07	96 995 313		01
163 048	01-0010-10	02	75 420 099	01-1120-10	29	75 516 417	01-2250-10	03	96 995 658	01-3342-10	02
176 438	01-3342-10	06	75 420 101	01-1212-10	08	75 516 419	01-1120-10	12	96 995 659	01-3344-10	01
182 018	01-1120-10	01	75 420 102		19	75 516 420		16	A 332 96	01-3342-10	13
		51	75 420 103		19	75 516 421		27	A 334 57	01-3358-10	07
182 023		51	75 420 118	01-1120-10	31	75 517 331	01-1140-10	03	A 334 81 A		12
		01	75 420 173	01-2250-10	17	75 518 393	01-2221-10	06	A 335 90 A	01-3342-10	11
190 326	01-1212-10	11	75 421 901	01-1120-10	16	75 520 086	01-2250-10	19	A 343 98	01-3430-10	09
103 402		21	75 427 388	01-2250-10	16	75 521 048	01-1142-10	03	A 343 98 A		09
105 828	01-1120-10	51	75 427 958	01-1142-10	04	75 521 078	01-1140-10	06	A 343 98 B		09
105 834		51	75 427 959		04	75 521 624	01-2250-10	04	A 343 98 C		09
105 835		51	75 429 058	01-1212-10	13	75 521 625	01-1142-10	01	A 343 98 D		09
458 009	01-1140-10	07	75 432 324		04	75 524 524	01-3303-10	02	A 344 5 A	01-3344-10	16
	01-2250-10	20	75 467 070	01-1120-10	17	75 524 525	01-3314-10	01	AK 334 3 A	01-3358-10	05
478 009	01-1140-10	08	75 478 957		02	75 524 593	01-1212-10	09	AM 124 9 A	01-1120-10	10
	01-3303-10	08	75 487 233		19	75 527 576	01-3430-10	06	AM 331 3 C	01-3303-10	03
688 009	01-3358-10	16	75 488 893	01-2221-10	03	95 495 074	01-1212-10	17	AM 331 86 A		07
104 009	01-2250-10	05	75 488 894		04	95 496 417		17	AM 332 1 E	01-3342-10	01
113 009	01-3355-10	08	75 490 327	01-1212-10	12	95 496 767	01-3342-10	07	AM 333 2 A		05
829 009	01-2221-10	11	75 491 083	01-2221-10	06	95 496 879	01-1212-10	18	AM 333 220	01-3344-10	08
111 009		12	75 491 633	01-1120-10	11	95 533 239		03	AM 333 221		08
162 139	01-1120-10	23	75 492 142	01-2221-10	09	95 543 284	01-0010-10	51	AM 333 222		08
162 549		24	75 503 614	01-2250-10	14	95 548 236	01-1212-10	05	AM 333 223		08
163 029	01-1142-10	06	75 504 636	01-1120-10	05		01-2221-10	01	AM 333 224		08
163 039		06	75 504 637		15	95 558 232	01-3323-10	04	AM 333 225		08
163 049		06	75 508 466	01-2250-10	06	95 559 486	01-1212-10	02	AM 333 226		08
163 059		05	75 508 467		06	95 559 620	01-2221-10	17	AM 333 227		08
163 069		05	75 511 563	01-3430-10	03	95 563 547	01-3303-10	01	AM 333 5 C		02
165 009	01-3314-10	09	75 515 280	01-2250-10	13	95 563 550	01-3342-10	01	AM 334 1	01-3355-10	01
165 019		10	75 516 347	01-1212-10	07	95 571 133	01-3300-10	01	AM 334 10		03
165 029	01-1120-10	23	75 516 348		07	95 572 590	01-3344-10	10	AM 334 100	01-3314-10	02
170 539	01-1212-10	06	75 516 356		04	95 573 978	01-3303-10	04	AM 334 103 A		05
178 129	01-2250-10	21	75 516 364		14		01-1140-10	04	AM 334 106	01-3358-10	13
202 299	01-3344-10	13	75 516 381	01-1120-10	09	95 574 075	01-3300-10	01	AM 334 11	01-3355-10	07
203 529	01-3430-10	10	75 516 382		13	95 581 779	01-2250-10	02	AM 334 23	01-3314-10	06

B05 ↑			INDEX					
NUMERO	SOUS-GROUPE	REP	NUMERO	SOUS-GROUPE	REP	NUMERO	SOUS-GROUPE	REP
AM 334 6	01-3355-10	04	AM 344 330		09	79 03 101 776		16
AM 334 62	01-3358-10	10	AM 344 96 A		15		01-1142-10	09
AM 334 7	01-3355-10	05	AM 381 1 B	01-3323-10	01	79 03 101 777	01-3314-10	11
AM 334 8 A		06	AT 381 3 A		02	79 03 101 786	01-1142-10	09
AM 334 9		02	AY 334 460 A	01-3358-10	03	79 03 101 806	01-3358-10	17
AM 334 95 A	01-3314-10	03	AY 334 461 A		04	79 03 201 012	01-2221-10	14
AM 334 97		04	AY 334 51		06	79 03 201 060	01-3314-10	11
AM 335 04 B	01-3342-10	03	AY 334 73		09	79 03 234 016	01-3358-10	20
AM 335 90	01-3344-10	14	AY 334 89		15			
AM 343 4 A	01-3430-10	04	AY 344 01	01-3430-10	02			
AM 343 7		07	AYA 124 63	01-1120-10	08			
AM 343 7 B		07	AYB 333 3	01-3342-10	04			
AM 343 7 D		07	AYB 333 4	01-3344-10	03			
AM 343 7 F		07	AZ 114 91	01-2250-10	08			
AM 343 8		08		01-1140-10	05			
AM 343 8 B		08	AZ 331 99	01-1142-10	02			
AM 343 8 D		08		01-3314-10	08			
AM 343 8 F		08	AZ 332 2	01-3344-10	06			
AM 343 8 H		08	AZ 332 4	01-3342-10	12			
AM 343 8 J		08	AZ 332 48	01-3344-10	07			
AM 343 8 L		08	AZ 333 7		04			
AM 344 300	01-3344-10	09	AZ 333 92		05			
AM 344 301		09	AZ 334 80	01-3358-10	11			
AM 344 302		09	AZ 343 1	01-3430-10	01			
AM 344 303		09	AZ 343 198 A		09			
AM 344 304		09	AZ 343 5		05			
AM 344 305		09	ZC 9612 607 U	01-1212-10	16			
AM 344 306		09	ZC 9613 037 U	01-3303-10	06			
AM 344 307		09	ZC 9620 275 U	01-3344-10	11			
AM 344 308		09	ZC 9620 361 U		12			
AM 344 309		09	ZC 9620 374 U	01-3342-10	09			
AM 344 310		09	ZC 9620 542 U		10			
AM 344 311		09	79 03 001 585	01-1142-10	07			
AM 344 312		09	79 03 032 036		10			
AM 344 313		09		01-3356-10	21			
AM 344 314		09	79 03 032 252	01-3314-10	19			
AM 344 315		09	79 03 033 018	01-1120-10	29			
AM 344 316		09	79 03 053 390	01-3358-10	19			
AM 344 317		09	79 03 055 019	01-3314-10	17			
AM 344 318		09	79 03 056 012	01-3358-10	18			
AM 344 319		09	79 03 056 017	01-3314-10	18			
AM 344 320		09	79 03 057 096	01-1120-10	28			
AM 344 321		09	79 03 058 011	01-2221-10	13			
AM 344 322		09	79 03 065 153		10			
AM 344 323		09	79 03 066 999	01-3358-10	14			
AM 344 324		09	79 03 087 053	01-1212-10	17			
AM 344 325		09	79 03 087 054		17			
AM 344 326		09	79 03 087 086		16			
AM 344 327		09	79 03 090 276	01-3342-10	08			
AM 344 328		09	79 03 101 755		14			
AM 344 329		09	79 03 101 760	01-3314-10	15			

15/02/91 1117	<b>TABLEAU DES VUES</b> AUFSTELLUNG DER BILDER TABLE OF PICTURE TABLA DE VISTAS TABELLA DELLE VEDUTE	<b>GROUPE</b> GROUP GROUP <b>02</b> GRUPO GRUPPO			<b>ALLUMEUR</b> ZUENDVERTEILER IGNITION DISTRIBUTOR DISTRIBUTOR SPINTEROGENO • <b>DUCELLIER</b> • <b>FEMSA</b>	2112-10 2112-20	<b>C14 C15</b> <b>D15 D14</b>
	<b>SOUS-GROUPE</b> UNTERGRUPPE SUBGROUP SUBGRUPO SOTTOGRUPPO		<b>NUMERO</b> NUMMER NUMBER NUMERO NUMERO	<b>VUE</b> BILD PICTURE VISTA VEDUTA	<b>BOBINE BOUGIE FAISCEAU D'ALLUMAGE</b> ZUENDKABELBUENDEL -KERZE.-SPULE IGNITION HARNESS-SPARK PLUG-COIL BOBINA BUJIA -CABLEADO ENCENDIDO BOBINA CANDELA-FASCIO ACCENSIONE	2120-10	<b>D13 D12</b>
	<b>BULURE ADMISSION-ECHAPPEMENT</b> -UND AUSLASSKROEMMER ET AND EXHAUST MANIFOLD LECTOR DE ADMISION Y ESCAPE LLETTORE ASPIRAZIONE ESCARICO		1411-10 1411-20	<b>C02</b> <b>C03</b>	<b>EMBRAYAGE</b> KUPPUNG CLUTCH EMBRAGUE FRIZIONE - ▶ 1977	3120-10	<b>D11</b>
	)- ▶ 11/79				<b>EMBRAYAGE CENTRIFUGE</b> FLIEHKRAFTKUPPLUNG CENTRIFUGAL CLUTCH EMBRAGUE CENTRIFUGO FRIZIONE CENTRIFUGA - ▶ 2425	3121-10	<b>D10 D09</b>
	<b>MANDE D'ACCELERATEUR</b> SPEDALBETAETIGUNG CELERATOR CONTROL MDO DE ACELERADOR MANDO DEL ACCELERATORE		1419-10 1419-20	<b>C04 C05</b> <b>C06</b>	<b>EMBRAYAGE A DIAPHRAGME</b> KUPPLUNG MIT FEDERSCHEIBE CLUTCH WITH DIAFRAGME EMBRAGUE A DIAFRAGMA FRIZIONE A DIAFRAMMA - 1978 ▶	3124-10	<b>D08 D07</b>
	)- ▶ 11/79				<b>ALTERNATEUR</b> WECHSELSTROMGENERATOR ALTERNATOR ALTERNADOR ALTERNATORE • <b>DUCELLIER 7532 E</b> • <b>PARIS RHONE A 11 M 12</b> • <b>FEMSA ALN 12-1</b> • <b>ISKRA AAG 0702</b>	5320-10 5320-20 5320-30 5320-40	<b>D06</b> <b>D05</b> <b>D04</b> <b>D03</b>
	<b>RBURATEUR</b> RGASER RBURETTOR RBURADOR RBURATORE		1434-10 1434-15 1434-20	<b>C07</b> <b>C08</b> <b>C09</b>	<b>ALTERNATEUR - FIXATION COURROIE</b> WECHSELSTROMGENERATOR-KEIRIEMENBETESTGG ALTERNATOR - BELT FASTENING ALTERNADOR-FIJACION CORREA ALTERNATORE-FISSAGGIO CINGHIA	5324-10	<b>O02</b>
	<b>OLEX - SAUF EMBRAYAGE CENTRIFUGE</b> <b>OLEX 12 720 000 - EMBRAYAGE CENTRIFUGE</b> <b>OLEX 34 PICS REP 193 - 3 PICS REP 194 - (D) - ▶ 11/79</b>						
	<b>RBURATEUR-NECESSAIRE DE REPARATION</b> RGASER - REPARATURSATZ RBURETTOR REPAIR KIT RBURADOR JUEGO REPARACION RBURATORE NECESSARIO RIPARACIONE		1438-10 1438-20	<b>C10</b> <b>C11</b>			
	<b>OLEX</b> <b>OLEX - (J) - ▶ 11/79</b>						
	<b>TRE A AIR</b> TFILTER FILTER TRO DE AIRE TRO ARIA		1710-10	<b>C12 C13</b>			

<p>15/02/91  1117 <b>TABLEAU DES VUES</b>  <b>AUFSTELLUNG DER BILDER</b>  <b>TABLE OF PICTURE</b>  B02 ↑ <b>TABLA DE VISTAS</b>  <b>TABELLA DELLE VEDUTE</b></p>	<p><b>GROUPE</b>  <b>GROUP</b>  <b>GROUP 02</b>  <b>GRUPO</b>  <b>GRUPPO</b></p>	
<p><b>SOUS-GROUPE</b>  <b>UNTERGRUPPE</b>  <b>SUBGROUP</b>  <b>SUBGRUPO</b>  <b>SOTTOGRUPPO</b></p>	<p><b>NUMERO</b>  <b>NUMMER</b>  <b>NUMBER</b>  <b>NUMERO</b>  <b>NUMERO</b></p>	<p><b>VUE</b>  <b>BILD</b>  <b>PICTURE</b>  <b>VISTA</b>  <b>VEDUTA</b></p>
<p><b>DEMARREUR</b>  <b>ANLASSER</b>  <b>STARTER</b>  <b>MOTOR DE ARRANQUE</b>  <b>MOTORINO AVVIAMENTO</b>  - <b>DUCELLIER</b>  - <b>PARIS RHONE D 8 E 148</b>  - <b>PARIS RHONE D 9 E 93</b>  - <b>ISKRA AZE 0305</b>  - <b>FEMSA MTA 12-30 - ► 2641</b>  - <b>BOSCH 9000141104 - 2642 ►</b></p>	<p><b>5330-10</b>  <b>5330-20</b>  <b>5330-25</b>  <b>5330-30</b>  <b>5330-40</b>  <b>5330-45</b></p>	<p><b>D01 E01</b>  <b>E02</b>  <b>E03</b>  <b>E04 E05</b>  <b>E06 E07</b>  <b>E08 E09</b></p>



**TUBULURE ADMISSION-ECHAPPEMENT**  
**EIN-UND AUSLASSKRUEMMER**  
**INLET AND EXHAUST MANIFOLD**  
**COLECTOR DE ADMISION Y ESCAPE**  
**COLLETTORE ASPIRAZIONE ESCARICO**

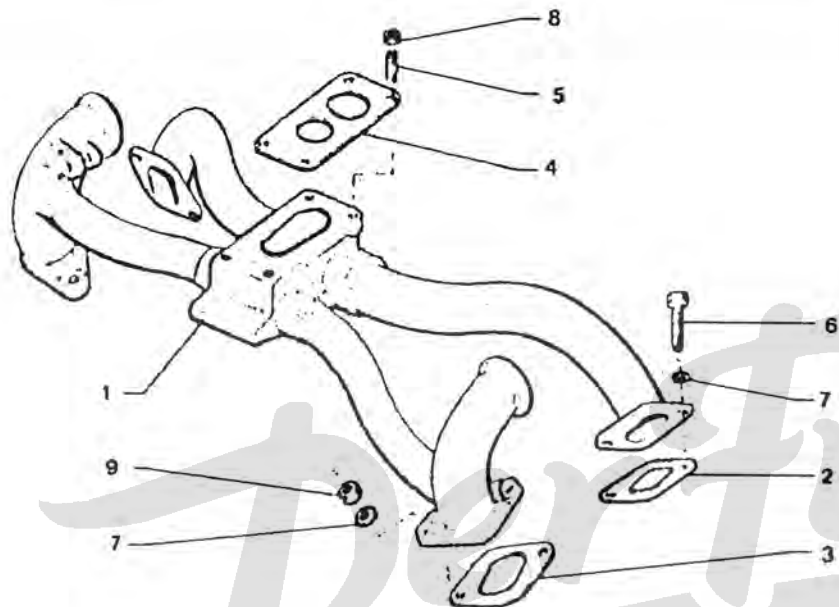

1114

2-141-10  
 Z1411100

- **NOTA: MONTAGE CARBURATEUR DOUBLE-CORPS**
- **NOTA.MONTAGE ZWEISTUFENVERGASER**
- **NOTE:ASSEMBLING CARBURETTER TWO-BARREL**
- **NOTA.MONTAGE CARBURADOR DE DOBLE CUERPO**
- **MONTAGGIO CARBURATORE A DOPPIO CONDOTTO**

01	95 581 013	01	RMP AM141 1K	TUBULURE KRUEMMER MAIFOLD COLECTOR COLLETTORE
----	------------	----	--------------	---

02	75 491 225	02	28,5X43,5 ADM	JOINT DICHTUNG MANIFOL GASKET JUNTA COLECTOR GUARNIZIONE
03	75 491 352	02	ENT 63 ECH	-
04	75 490 505	01	E 7-2 DIAM INT 27 G	ENTRETOISE ABSTANDSSTUECK SPACER DISTANCIADOR DISTANZIALE
05	26 161 509	02	DIAM 8X1,25-37	GOUJON STEBOLZEN STUD ESPARRAGO PERNO
	26 161 619	02	D'AM 8X1,25-42	-
06	95 623 773	04	TH7X1,00-25	VIS SCHRAUBE SCREW TORNILLO VITE
07	79 03 056 012	08	CR 7,3X12	RONDELLE GROWER GROWERSCHEIBE SPRING WASHER ARANDELA RONDELLA GROWER
08	79 03 032 124	04	HE8X1,25	ECROU MUTTER NUT TUERCA DADO
09	79 03 032 249	04	HE 7X1,00	

15/02/91  
1117 02-1419-10  
PAGE : 1  
C04 ↑

**COMMANDE D'ACCELERATEUR**  
GASPEDALBETAETIGUNG  
ACCELERATOR CONTROL  
MANDO DE ACELERADOR  
COMANDO DEL ACCELERATORE

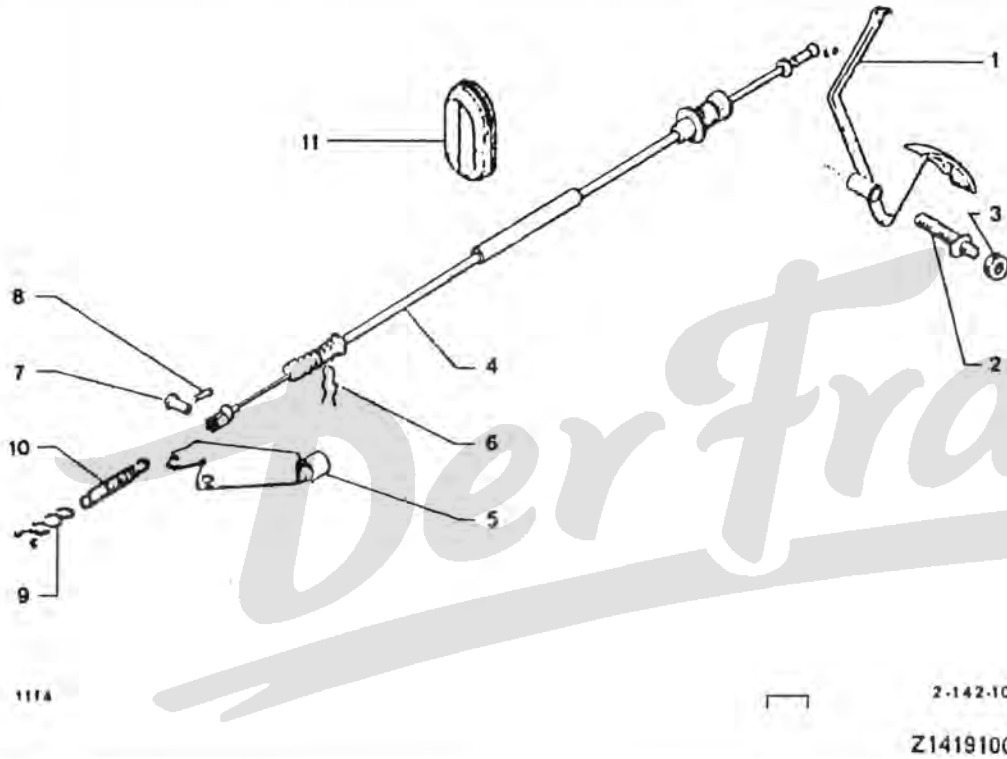

1114

2-142-10  
Z1419100

- NOTA: MONTAGE CARBURATEUR DOUBLE-CORPS
- NOTA:MONTAGE ZWEISTUFENVERGASER
- NOTE:ASSEMBLING CABURETTER TWO BARREL
- NOTA:MONTAGE CARBURATORE DE DOBLE CUERPO
- NOTA:MONTAGIO CARBURATORE A DOPPIO CONDOTTO

01	5 507 099	01	PEDALE GASPEDAL ACCELERAT PEDAL PEDAL PEDALE
----	-----------	----	--

02	75 515 541	01	DIAM 9X1,25 L:12-32	AXE DE PEDALE PEDALBOLZEN PEDAL SPINDLE EJE PEDAL PERNO PEDALE
03	25 223 019	01	HE 9X1,25	ECROU MUTTER NUT TUERCA DADO
04	5 507 100	01	LON 762	CABLE DE CDE BET.-ZUG CONTROL CABLE CABLE ACELERAD. CAVO DI COMANDO
05	95 576 962	01	RMP 25223009 ▶ 1788	SUPPORT D'ARRET HALTER SHEATH BRACKET SOPORTE SUPPORTO
06	79 03 066 995	01		EPINGLE KLAMMER ACLR CABLE PIN GRUPILLA GRAFFETTA
07	AM 142 67	01		AXE DE SECTEUR BOLZEN F.SEGM. SECTION PIN EJE SECTOR PERNO SETTORE
08	79 03 066 999	01	DIAM 2-LON-20	EPINGLE SPANGE BRAKE PLATE PIN GRUPILLA SPILLO
09	5 509 540	01	EMBCEN ▶ 12/80	AGRAFE KLAMMER CLIP GRAPA AGRAFE
	75 420 121	01	EMBNOR 12/80 ▶	-
10	75 420 119	01	DIAM EXT 13	RESSORT FEDER CABLE SPRING MUELLE CABLE MOLLA

.../...

**CARBURATEUR**  
VERGASER  
CARBURETTOR  
CARBURADOR  
CARBURATORE

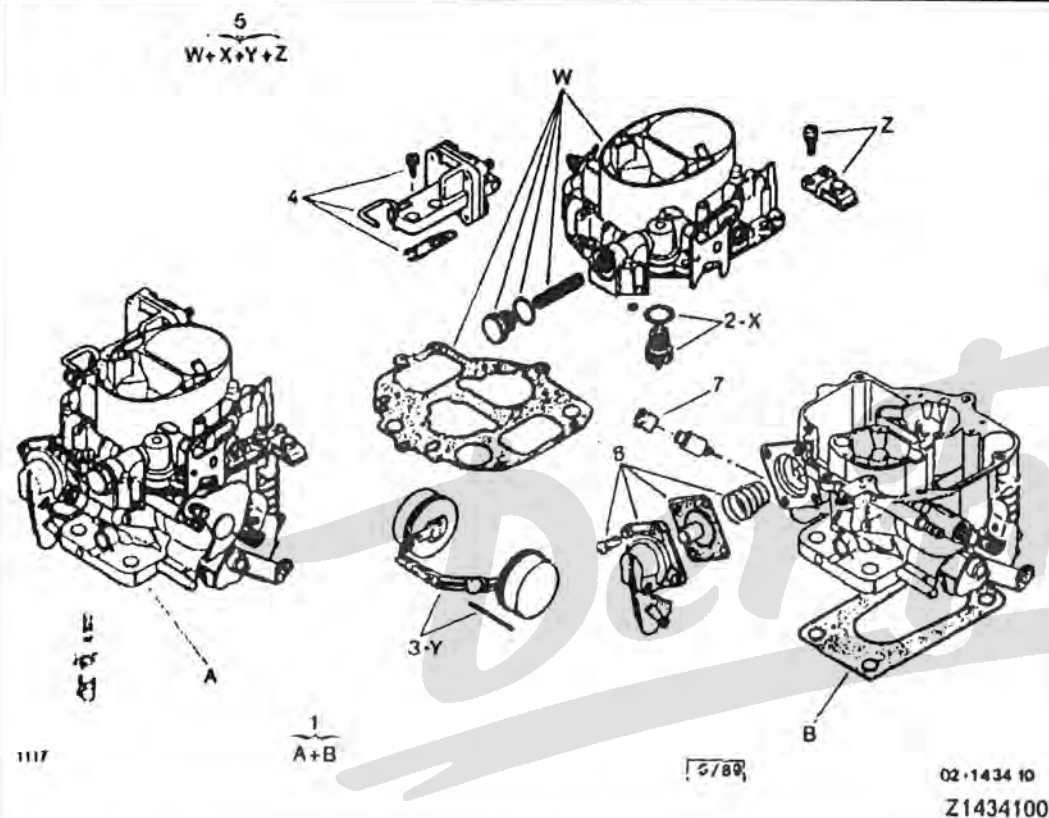

**SOLEX**  
**SAUF EMBRAYAGE CENTRIFUGE**

01	95 545 941	01	12 992000 RMP 5501073 12719000 26/35 SCIC REP197 > 6/80	CARBURATEUR VERGASER CARBURETTOR CARBURADOR CARBURATORE
02	5 486 485	01	AVEC JOINT ▶ 2092	POINTEAU CARBU. VERG.NADELVENT. CARB NEEDL VALV VALVULA AGUJA GALLEGGIANTE
	95 577 882	01	AVEC JOINT 2093 ▶	-

03	5 437 082	01	ASS	FLOTTEUR SCHWIMMER CARBURETR FLOAT FLOTADOR GALLEGGIANTE
04	95 568 478	01	06/80 ▶	ENS ASSISTANCE UNTERST.SATZ ASSISTED ASSY ENS ASISTENCIA INS.ASSISTENZA
05	95 582 995 NFP	01	COMPLET 2124 ▶	DESSUS DE CUVE GEHAEUSEDECKEL FLOAT CHB COVER CUERPO SUPERIOR PARTE SUP.VASCH
06	95 595 730	01	ENS	POMPE REPRISE BESCHLEUNIGPUMP ACCELERAT PUMP BOMBA ACELERACI POMPA RIPRESA
07	5 501 075	01	DIAM 9,2-10 HAUT13,4	BOUCHON DE VIS STOPFEN R.SCHRA SCREW PLUG CAPUCHON TAPPO VITE

15/02/91  
1117 02-1434-15  
PAGE : 1  
C08 ↑

**CARBURATEUR**  
VERGASER  
CARBURETTOR  
CARBURADOR  
CARBURATORE

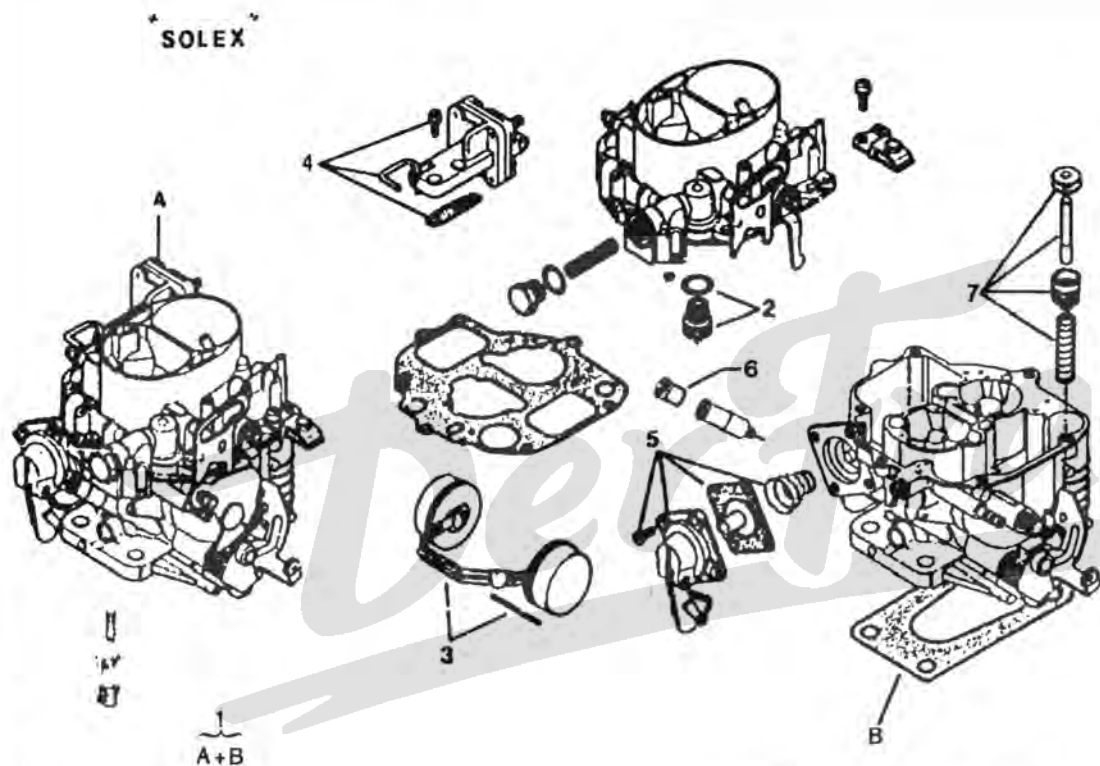

02	5 486 485	01	AVEC JOINT	► 09/81	POINTEAU CARBU. VERG.NADELVENT. CARB NEEDL VALV VALVULA AGUJA GALLEGGIANTE
	95 577 882	01	AVEC JOINT	09/81 ►	-
03	5 437 082	01	ASS		FLOTTEUR SCHWIMMER CARBURETR FLOAT FLOTADOR GALLEGGIANTE
04	95 568 478	01		06/80 ►	ENS ASSISTANCE UNTERST.SATZ ASSISTED ASSY ENS ASISTENCIA INS.ASSISTENZA
05	95 595 730	01	ENS		POMPE REPRISE BESCHLEUNIGPUMP ACCELERAT PUMP BOMBA ACELERACI POMPA RIPRESA
06	5 501 075	01	DIAM 9,2-10 HAUT13,4		BOUCHON DE VIS STOPFEN R.SCHRA SCREW PLUG CAPUCHON TAPPO VITE

**SOLEX 12 720 000**  
**EMBAYAGE CENTRIFUGE**

- NOTA: LES PIECES NON REPEREES SONT NFP

01	5 501 074	01	12 720000 26/35 SCIC REP 198	► 06/80	CARBURATEUR VERGASER CARBURETTOR CARBURADOR CARBURATORE
	95 545 941	01	12 992000 12 993000-26/35 SCIC REP 226	06/80 ►	-

**CARBURATEUR**  
 VERGASER  
 CARBURETTOR  
 CARBURADOR  
 CARBURATORE

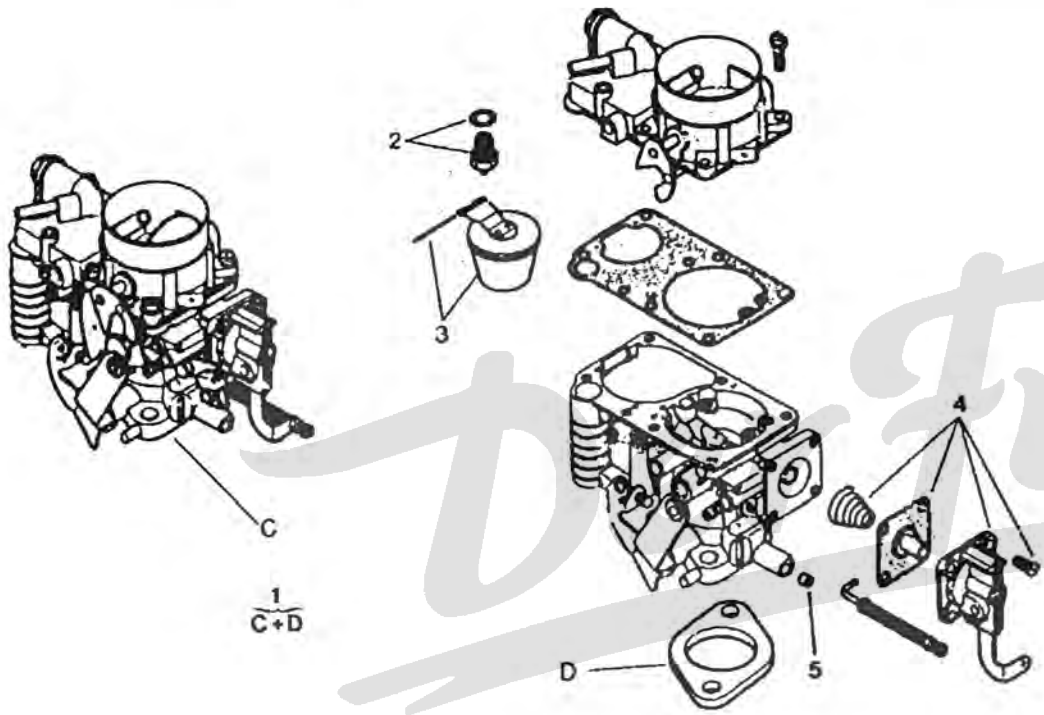

[ 6/89 ]      02-1434 20  
 Z1434200

**SOLEX 34 PICS REP 193 - 34 PICS REP 194**  
 (D)  
 ► 11/79

- NOTA: POUR L'EMPLOI AVEC UN EMBRAYAGE NORMAL, RETOURNER LE LEVIER (L) DANS LA POSITION INVERSE

02	95 533 290	01		FLOTTEUR SCHWIMMER CARBURETR FLOAT FLOTADOR GALLEGGIANTE
03	5 478 724	01		POINTEAU CARBU. VERG.NADELVENT. CARB NEEDL VALV VALVULA AGUJA GALLEGGIANTE
04	5 504 891	01	ENS	POMPE REPRISE BESCHLEUNIGPUMP ACCELERAT PUMP BOMBA ACELERACI POMPA RIPRESA
05	75 489 718	01	DIAM EXT 6,70-H4	BOUCHON DE VIS STOPFEN R.SCHRA SCREW PLUG CAPUCHON TAPPO VITE
01	5 501 070	01	COMPLET	CARBURATEUR VERGASER CARBURETTOR CARBURADOR CARBURATORE

15/02/91  
 1117 02-1438-10  
 PAGE : 1  
 C10 ↑

**CARBURATEUR-NECESSAIRE DE REPARATION**  
 VERGASER - REPARATURSATZ  
 CARBURETTOR REPAIR KIT  
 CARBURADOR JUEGO REPARACION  
 CARBURATORE NECESSARIO RIPARAZIONE

03

75 515 610

01 SANS JOINTS  
 DE CORPS DE CUVE

NEC CARBURATEUR  
 REP-SATZ  
 CARB REPAIR KIT  
 JUEGO REPARACI.  
 NECESSARIO

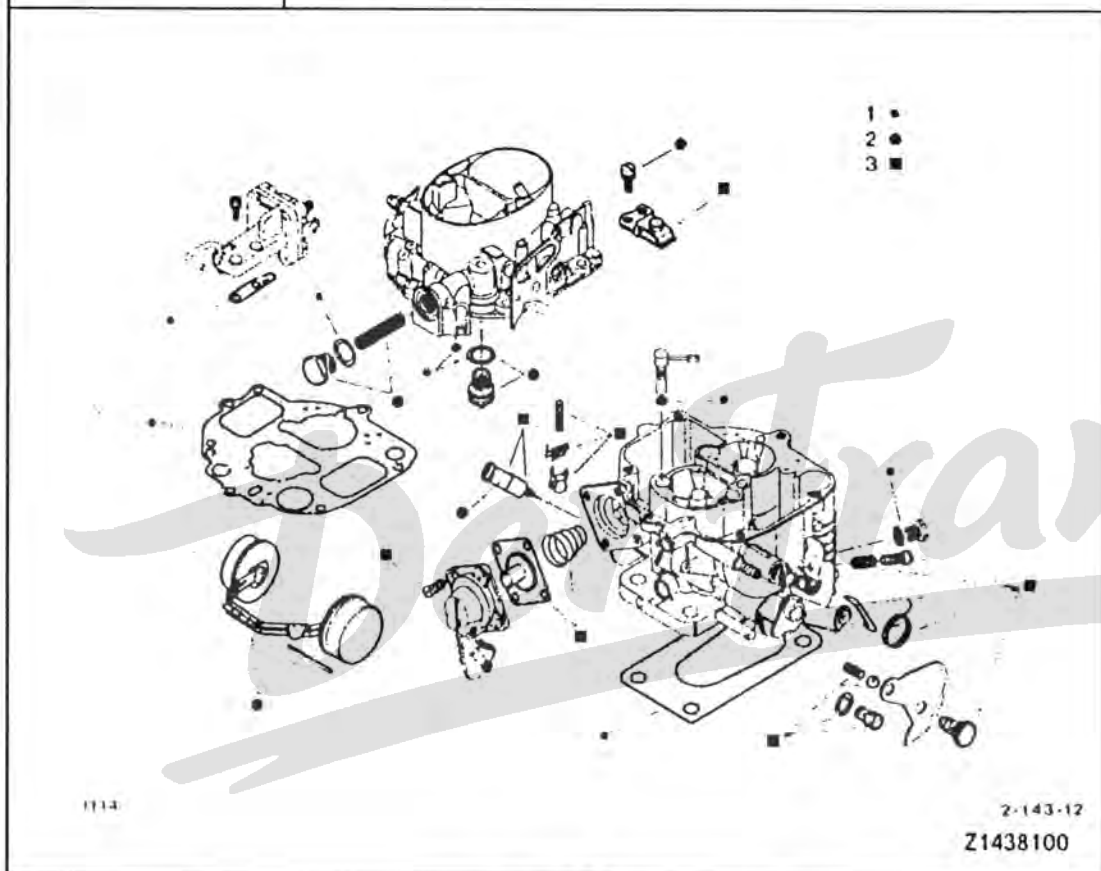

**SOLEX**

01	5 451 034	01	ENS	POCHETTE JOINTS DICHTSATZ CARB GASKET KIT JUEGO DE JUNTAS SERIE GUARNIZ.
02	75 515 609	01	SANS JOINTS DE DESSUS DE CUVE ▶ 1757	NEC CARBURATEUR REP-SATZ CARB REPAIR KIT JUEGO REPARACI. NECESSARIO
	95 577 884	01	SANS JOINTS DE DESSUS DE CUVE 1758 ▶	-

15/02/91  
 1117 02-1438-20  
 PAGE : 1  
 C11 ↑

**CARBURATEUR-NECESSAIRE DE REPARATION**  
 VERGASER - REPARATURSATZ  
 CARBURETTOR REPAIR KIT  
 CARBURADOR JUEGO REPARACION  
 CARBURATORE NECESSARIO RIPARAZIONE

03

75 517 322

01

SANS JOINTS  
 DE CORPS DE CUVE

**NEC CARBURATEUR  
 REP-SATZ  
 CARB REPAIR KIT  
 JUEGO REPARACI.  
 NECESSARIO**

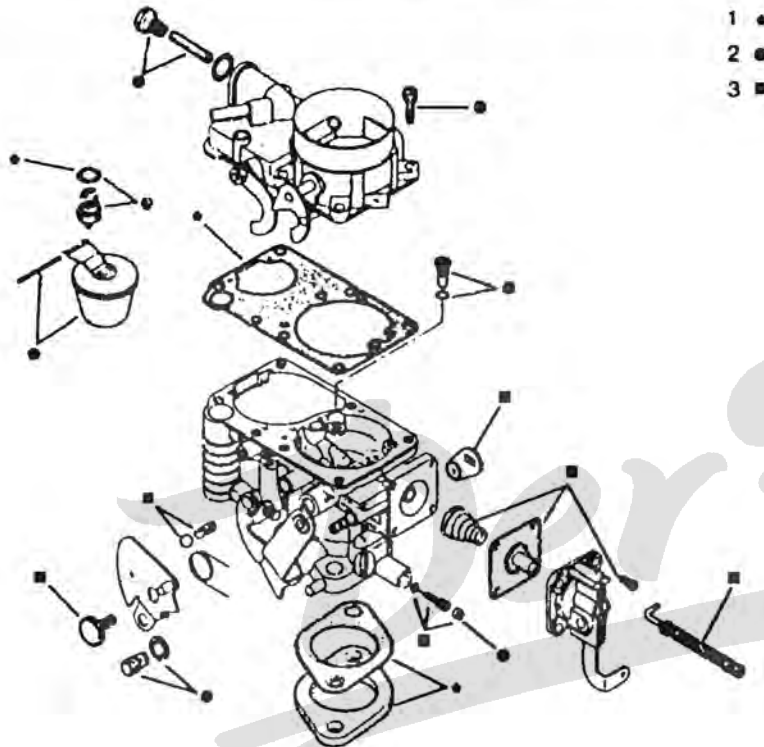

- 1 ●
- 2 ●
- 3 ■

Z1438200

Z1438200

**SOLEX  
 (D)  
 ► 11/79**

01

5 451 055

01 ENS

**JOINT DE CARBU.  
 VERGASERDICHTUN  
 CARBURET GASKET  
 JUNTA CARBURAD.  
 GUARNIZIONE**

02

75 517 320

01 SANS JOINTS  
 DESSUS DE CUVE

**NEC CARBURATEUR  
 REP-SATZ  
 CARB REPAIR KIT  
 JUEGO REPARACI.  
 NECESSARIO**

15/02/91  
 1117 02-1710-10  
 PAGE : 1  
 C12 ↑

FILTRE A AIR  
 LUFTFILTER  
 AIR FILTER  
 FILTRO DE AIRE  
 FILTRO ARIA

*MM7*

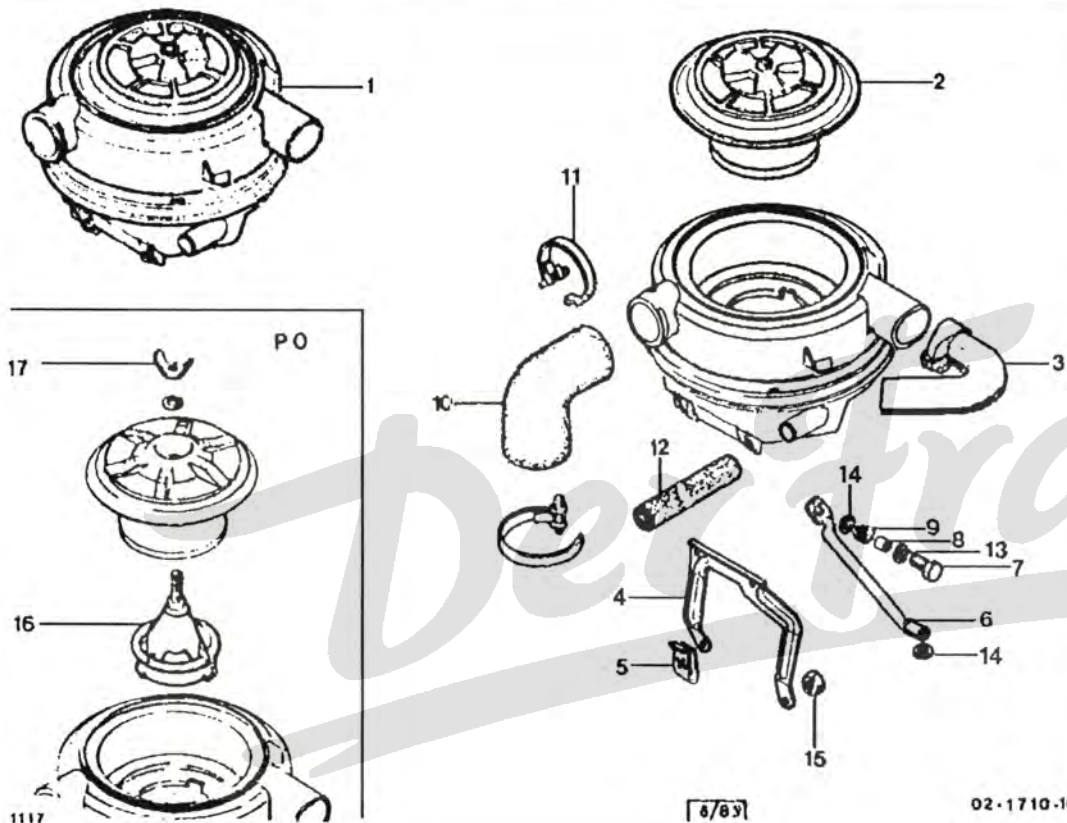

• NOTA: LES PIECES NON REPEREES SONT NFP

02	95 546 429	01		ELEMENT FILTRE EINSATZ FILTER ELEMENT ELEMENTO FILTR. ELEMENTO
	5 508 266	01	-ATMOSPHERE POUSSIERES	-
03	75 515 254	01		RACCORD AIR EINLASSSCHLAUCH FILTER AIR HOSE MANGUITO AIRE RACCORDO
04	75 529 967	01		SUPPORT DE COL HALTER F. ROHR PIPE BRACKET SOPORTE SUPPORTO
05	5 503 400	02	DIAM 6	ECROU MUTTER NUT TUERCA DADO
06	75 515 401	01	AR	SUPPORT DE COL HALTER F. ROHR PIPE BRACKET SOPORTE SUPPORTO
07	79 03 201 132	01	TH5X0,80-25	VIS TH SCHRAUBE CAPSCREW TORNILLO TH VITE
08	75 420 126	01	6X8X6,5	ENTRETOISE ABSTANDSSTUECK SPACER JUEGO DISTANCIA DISTANZIALE
09	75 521 653	01	DIAM INT8X16X6,5	BAGUE ELASTIQUE RING BUSHING CASQUILLO ELAS. BOCCOLA ELAST.
10	75 523 566	01	CC	RACCORD AIR EINLASSSCHLAUCH FILTER AIR HOSE MANGUITO AIRE RACCORDO
01	95 546 597	01	19544	FILTRE AIR SEC LUFTFILTER AIR FILTER FILTRO DE AIRE FILTRO ARIA
	5 508 267	01	19708 -ATMOSPHERE POUSSIERES	-



32/91

17 02-1710-10

GE : 2

3 ↑

FILTRE A AIR  
 LUFTFILTER  
 AIR FILTER  
 FILTRO DE AIRE  
 FILTRO ARIA

13

22 769 009

03 DIAM 5X20-E 1

RONDELLE GROWER  
 GROWERSCHEIBE  
 SPRING WASHER  
 ARANDELA  
 RONDELLA GROWER

14

95 624 273

01 DIAM 7.4 X 20 X 2

RONDELLE PLATE  
 FLACHSCHEIBE  
 PLAIN WASHER  
 ARANDELA PLANA  
 RONDELLA PIATTA

15

79 03 032 252  
 RP 7903232018

02 HE 10X1,50

ECROU HEXAGONAL  
 SECHSKANTMUTTER  
 HEXAGONAL NUT  
 TUERCA  
 DADO ESAGONALE

16

75 530 717

01 -ATMOSPHERE POUSSIERES

ENTRETOISE  
 ABSTANDSSTUECK  
 SPACER  
 JUEGO DISTANCIA  
 DISTANZIALE

17

75 530 718

01 -ATMOSPHERE POUSSIERES

ECROU OREILLES  
 FLUEGELMUTTER  
 FLY NUT  
 TUERCA MARIPOSA  
 DADO ORECCHI

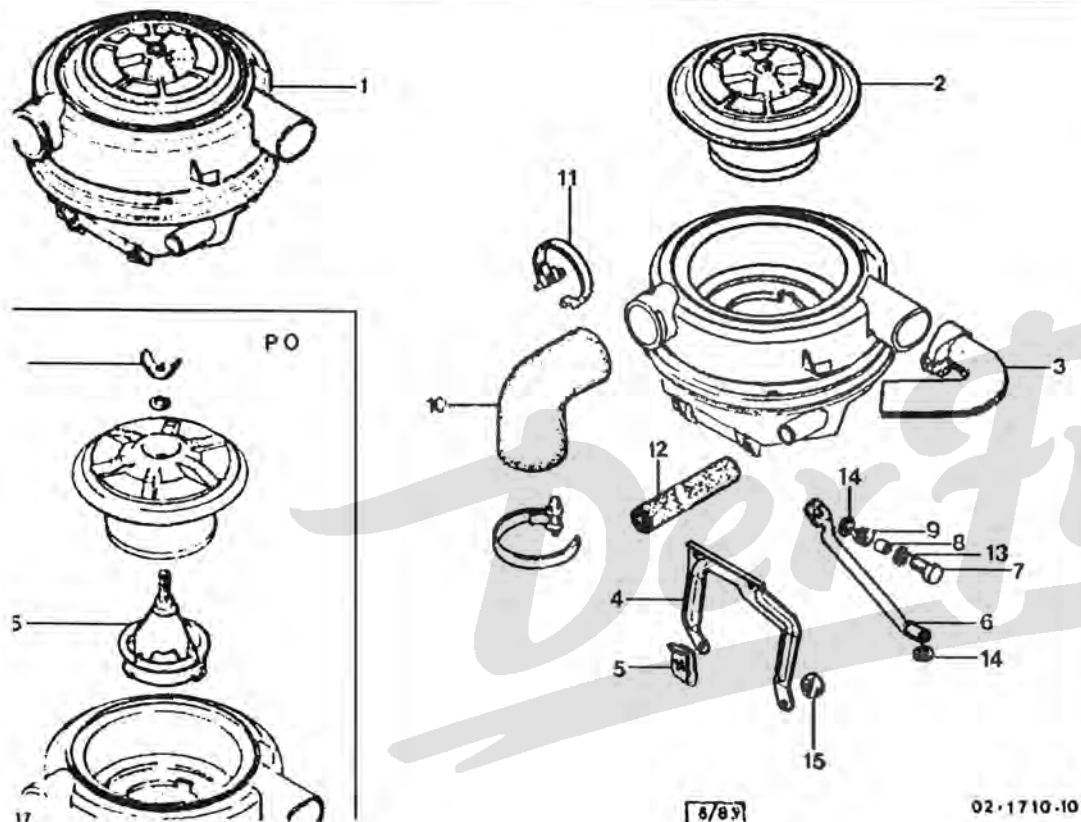

02-1710-10

Z1710100

22 559 029  
 NFP

01 LON 495

COLLIER  
 SCHELLE  
 ADJUST COLLAR  
 ABRAZADERA  
 COLLARE

AK 171 99

01 17X23X280

TUBE SOUPLE  
 VERBIND.ROHD  
 FLEXIBLE TUBE  
 TOBO FLEXIBLE  
 TUBO FLESSIBILE

15 02/91  
1117 02-2112-10  
PAGE : 1  
C14 ↑

**ALLUMEUR**  
ZUENDVERTEILER  
IGNITION DISTRIBUTOR  
DISTRIBUIDOR  
SPINTEROGENO

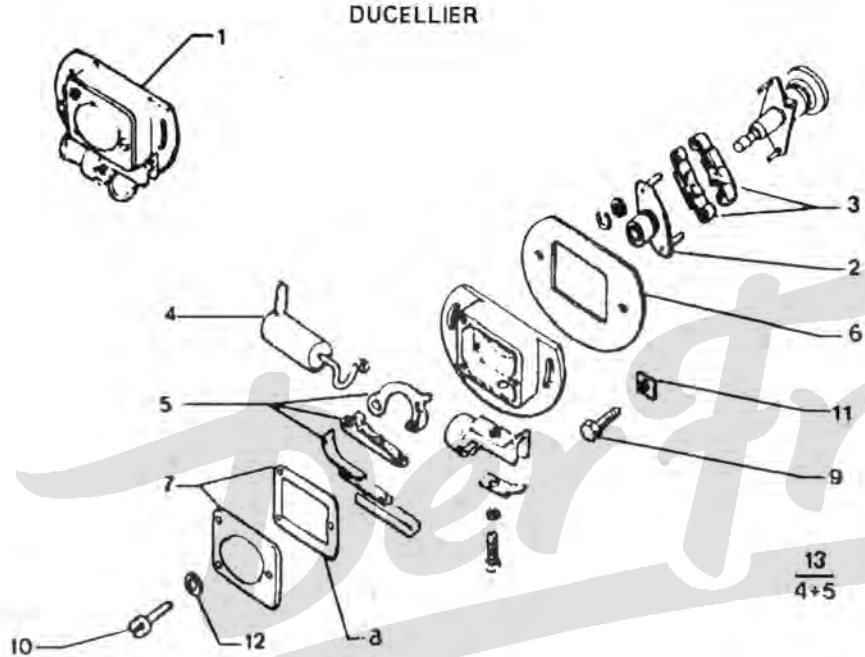

1117

14/89

02 2112-10

Z2112100

**DUCELLIER**

01	AZ 211 05	01	ALLUMEUR ZUENDVERTEILER DISTRIBUTOR DISTRIBUIDOR SPINTEROGENO	10	79 03 007 147	03	DIAM 4X0,70 LON 8	VIS TCB SCHRAUBE CAPSCREW TORNILLO TCB VITE
02	AM 211 204 A	01	CAME D'ALLUMEUR NOCKEN DISTRIBUTOR CAM LEVA CAMMA	11	5 427 438	02	DIAM 7,5X15X15	PLAQUETTE PLAETTCHEN DISTR FIX PLATE PLAQUETA PIASTRA

03	5 422 859	01	LON 31	JEU DE RESSORTS FEDERNSATZ DIST SPRING SET JUEGO MUELLES SERIE MOLLE
04	AZ 211 8	01		CONDENSATEUR KONDENSATOR IGNIT CONDENSER CONDENSADOR CONDENSATORE
05	AZ 211 17	01		RUPTEUR UNTERBRECHER CONTACT BREAKER RUPTOR SPAZZOLA ROTANT
06	AM 211 92 B	01	DIAM 95	TOLE PROTECTION ABSCHIRMBLECH GUARD SHEET MET PANTALLA PROTEC LAMIERA
07	AZ 211 9	01		COUVERCLE DECKEL COVER TAPA COPERCHIO
08	AZ 211 116	01	CC	JOINT CAOUTCHOU GUMMIDICHTUNG RUBBER SEAL JUNTA GOMA GUARNIZIONE GOM
09	79 03 001 708	01	DIAM 7X1,00-20	VIS TH SCHRAUBE CAPSCREW TORNILLO TH VITE
10	79 03 007 147	03	DIAM 4X0,70 LON 8	VIS TCB SCHRAUBE CAPSCREW TORNILLO TCB VITE
11	5 427 438	02	DIAM 7,5X15X15	PLAQUETTE PLAETTCHEN DISTR FIX PLATE PLAQUETA PIASTRA

.../...

15 02/91  
 1117 02-2112-10  
 PAGE : 2  
 C15 →

**ALLUMEUR**  
 ZUENDVERTEILER  
 IGNITION DISTRIBUTOR  
 DISTRIBUIDOR  
 SPINTEROGENO

**DUCELLIER**

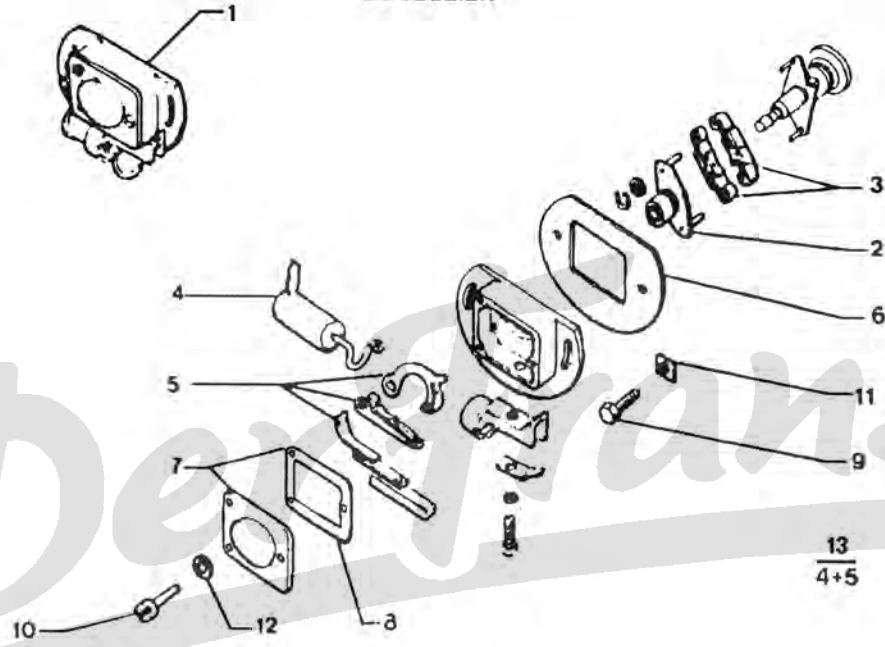

1117

14/89

02 2112-10

Z2112100

**DUCELLIER**

12	79 03 056 003	03	DIAM 4,2 X 8	RONDELLE A DENT ZAHNSCHEIBE SPRING WASHER ARANDELA RONDELLA DENTAT
13	5 489 274	01		KIT BASSE TENS. NIEDERSPANNSATZ LOW TENSION KIT KIT BAJA TENS. INSIEME BASSA T

15/02/91  
 1117 02-2112-20  
 PAGE : 1  
 D15 ↓

**ALLUMEUR**  
 ZUENDVERTEILER  
 IGNITION DISTRIBUTOR  
 DISTRIBUIDOR  
 SPINTEROGENO

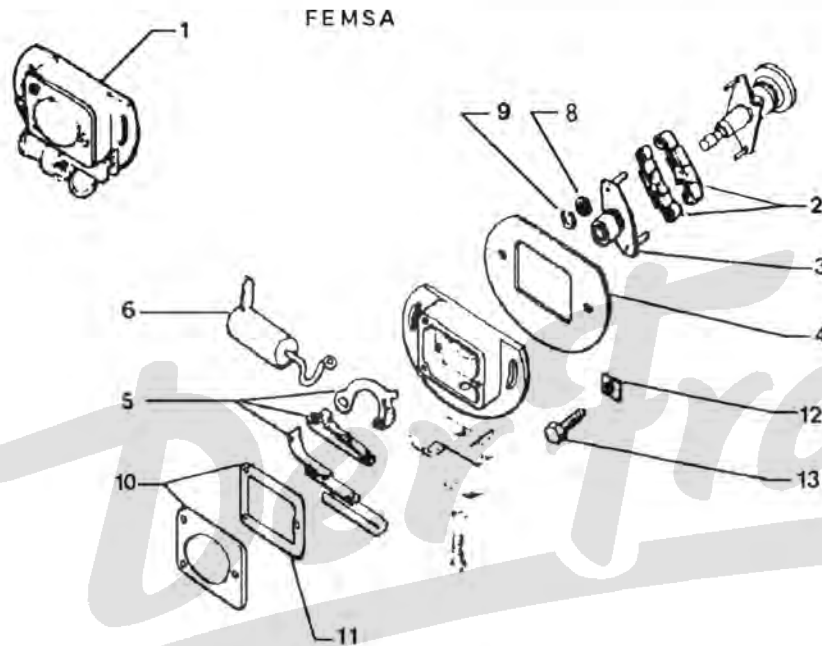

02 2112-10

Z2112200

**FEMSA**

01 5 474 742  
 RP AZ21105

01

**ALLUMEUR**  
 ZUENDVERTEILER  
 DISTRIBUTOR  
 DISTRIBUIDOR  
 SPINTEROGENO

02 5 474 733

01

**JEU DE RESSORTS**  
 FEDERNSATZ  
 DIST SPRING SET  
 JUEGO MUELLES  
 SERIE MOLLE

03	5 474 734	01		<b>CAME D'ALLUMEUR</b> NOCKEN DISTRIBUTOR CAM LEVA CAMMA
04	AM 211 92 B	01	DIAM 95	<b>TOLE PROTECTION</b> ABSCHIRMBLECH GUARD SHEET MET PANTALLA PROTEC LAMIERA
05	5 474 741	01		<b>JEU DE CONTACTS</b> KONTAKTESATZ BREAKR CONT SET JUEGO CONTACTOS SERIE CONTATTI
06	5 474 738	01		<b>CONDENSATEUR</b> KONDENSATOR IGNIT CONDENSER CONDENSADOR CONDENSATORE
07	5 474 740	01		<b>JEU DE PIECES</b> SATZ TEILE DISTRIBUTOR KIT JUEGO DE PIEZAS SERIE PEZZI
08	5 474 735	01		<b>RONDELLE BUTEE</b> EINSCHL SCHEIBE WASHER ARANDELA TOPE RONDELLA REGISP
09	5 474 736	01		<b>JONC D'ARRET</b> HALTERING CIRCLIP ANILLO DE Of & ANELLO ARREST
10	5 474 737	01		<b>COUVERCLE</b> DECKEL COVER TAPA COPERCHIO
11	5 474 739	01	CC	<b>JOINT</b> HALTERDICHTUNG SUPPORT SEAL JUNTA GUARIZIONE SUPP .../...

15/02/91  
 1117 02-2112-20  
 PAGE : 2  
 D14 ↓

**ALLUMEUR**  
 ZUENDVERTEILER  
 IGNITION DISTRIBUTOR  
 DISTRIBUIDOR  
 SPINTEROGENO

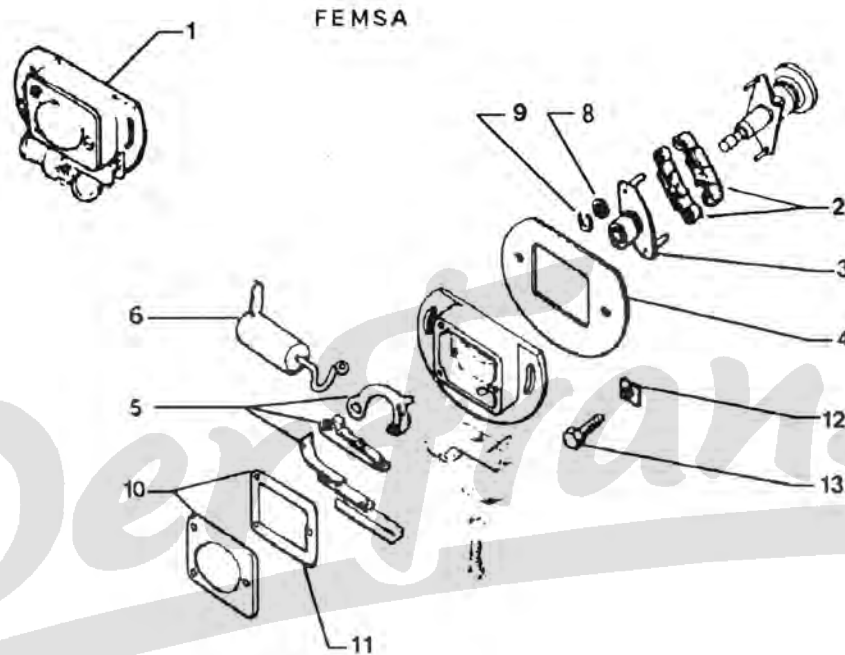

FEMSA

1117

02 2112-10

Z2112200

**FEMSA**

12	5 427 438	02	DIAM 7 5X15X15	PLAQUETTE PLAETTCHEN DISTR FIX PLATE PLAQUETA PIASTRA
13	79 03 001 708	02	DIAM 7X1.00-20	VIS TH SCHRAUBE CAPSCREW TORNILLO TH VITE

15/02/91  
1117 02-2112-10  
PAGE :1  
D13 ↓

**BOBINE BOUGIE FAISCEAU D'ALLUMAGE**  
ZUENDKABELBUENDEL - KERZE - SPULE  
IGNITION HARNESS - SPARK PLUG COIL  
BOBINA BUJIA CABLEADO ENCENDIDO  
BOBINA CANDELA-FASCIO ACCENSIONE

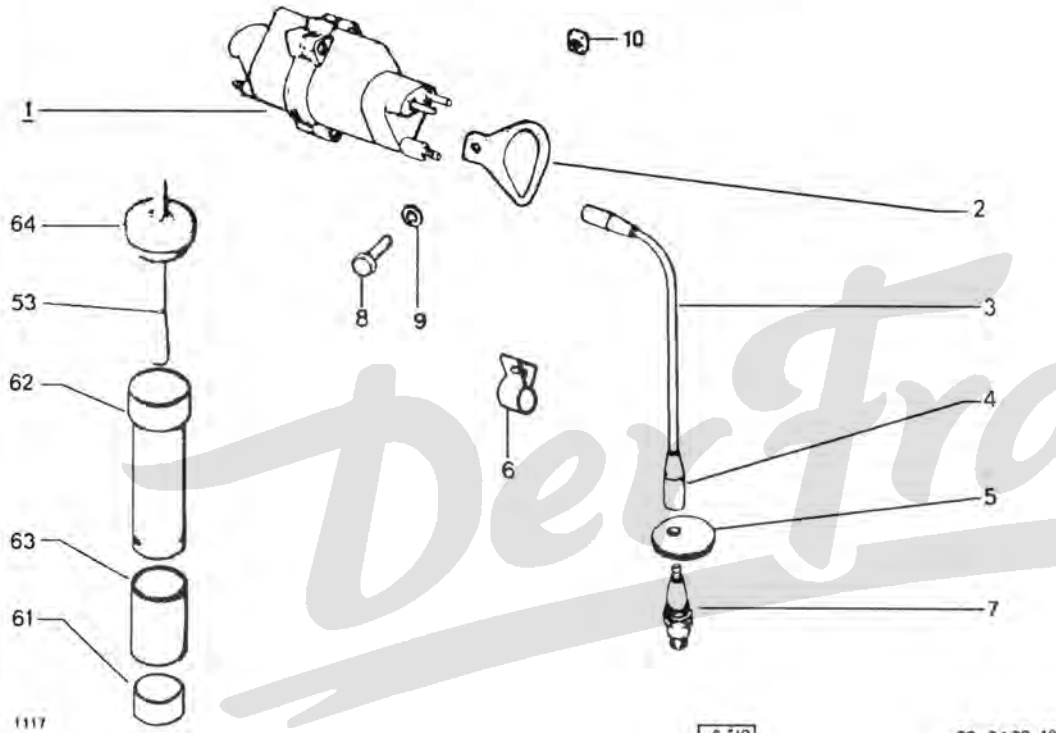

[ 6 19 ]

02 - 2120 10

Z2 20100

01 \* 95 539 008

01 FEMSA - BC 12-7  
DUCELLIER 520021A

**BOBINE ALLUMAGE**  
ZUENDSPULE  
IGNITION COIL  
BOBINA ENCENDI  
BOBINA ACCENSIO

02 75 510 566

02

**SUPPORT BOBINE**  
SPULENHALTER  
COIL BRACKET  
SOPORTE BOBINA  
SUPPORTO BOBINA

03	5 427 006	01	▶ 06 82	<b>FSC ALLUMAGE</b> MOTORKABEL IGNITION HARNES CABLEADO FASCIO
	95 495 646	01	07 82 ▶	
04	95 536 340	02	▶ 06 82	<b>PROTECTEUR</b> SCHUTZ HARNESS PROTECT PROTECTOR PROTEZIONE
	95 581 245	02	07 82 ▶	
05	95 569 088	02	DIAM 38	<b>OBTURATEUR</b> STOPFEN PLUG OBTURADOR OTTURATORE
06	AZ 212 140	01	G.	<b>SUPPORT</b> HALTER HARNESS BRACKET SOPORTE SUPPORTO
	AZ 212 140 A	01	D.	
07	AM 212 207 A	02	EYQUEM - 755	<b>BOUGIE</b> ZUENDKERZE SPARK-PLUG BUJIA CANDELA
	5 433 737	02	MARCHAL RMP A212 7C	
	AYB 212 7	02	AC -42F	
	95 618 377	02	BOSCH -W 5 AC RMP AZ 212 7A	
	95 619 038	02	CHAMPION L 82 C RMP DX 212 7B	
	5 418 536	02	MAGNETI-MARELLI CW7N	
08	79 03 007 065	02	4X35	<b>VIS TCB</b> SCHRAUBE CAPSCREW TORNILLO TCB VITE

.../...

12/91  
 7 02-2112-10  
 GE : 2  
 ? ↓

**BOBINE BOUGIE FAISCEAU D'ALLUMAGE**  
 ZUENDKABELBUENDEL - KERZE - SPULE  
 IGNITION HARNESS - SPARK PLUG COIL  
 BOBINA BUJIA CABLEADO ENCENDIDO  
 BOBINA CANDELA-FASCIO ACCENSIONE

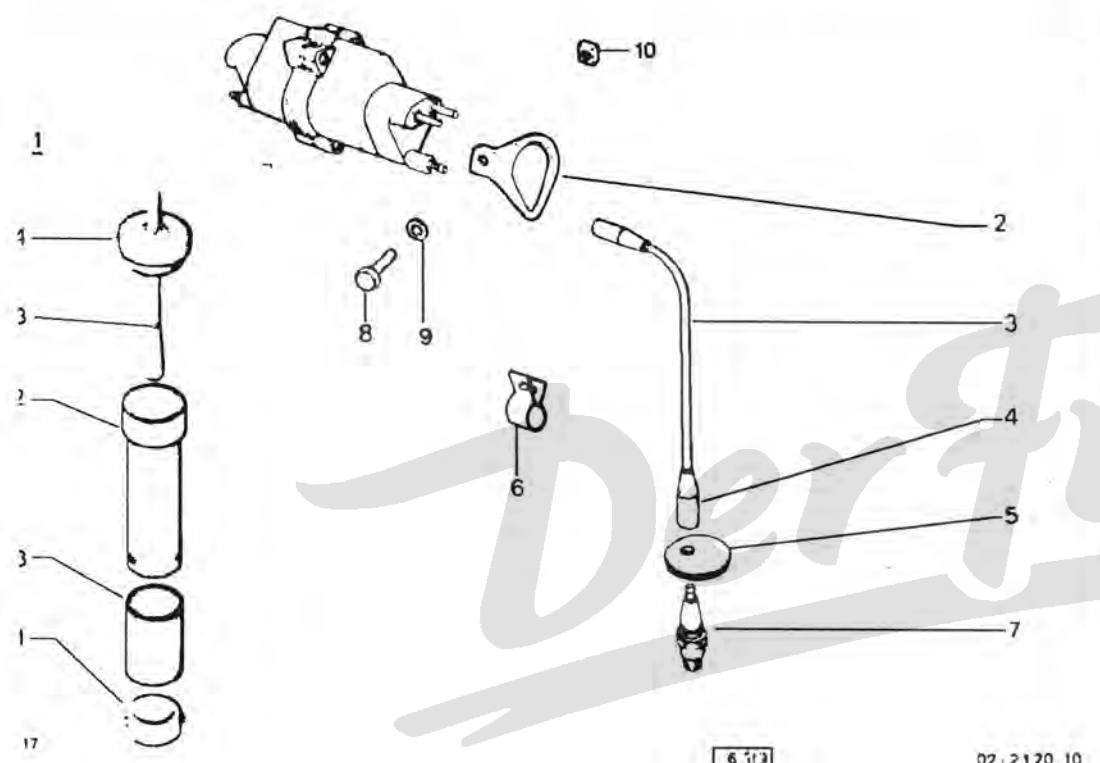

6 1/3 02-2120 10  
 Z2 20100

95 624 272	02 DIAM 4 X 8	<b>RONDELLE</b> SCHEIBE WASHER ARANDELA RONDELLA
79 03 032 003	02 HE 4X0,7	<b>ECROU HEXAGONAL</b> SECHSKANTMUTTER HEXAGONAL NUT TUERCA DADO ESAGONALE

53	95 493 444	01	-(D) -(DK) -(A) -(I)	11/79 ▶	<b>FSC ALLUMAGE</b> MOTORKABEL IGNITION HARNESS CABLEADO FASCIO
61	5 505 809	02	15X26X12 -(D) -(DK) -(A) -(I)	11/79 ▶ 06/81 ▶	<b>COUPELLE</b> TELLER CUP COPELA SCODELLINO
62	5 505 808	02	DIAM INT 26-30-H 96 -(D) -(DK) -(A) -(I)	11/79 ▶ 11/79 ▶ 11/81 ▶ 06/81 ▶	<b>TUBE DE BOUGIE</b> ZUENDKERZENROHR SPARK-PLUG TUBE TUBO BUJIA TUBO CANDELA
63	5 508 324	02	DIAM INT 26.5-H 40 -(D) -(DK) -(A) -(I)	11/79 ▶ 11/79 ▶ 11/79 ▶ 06/81 ▶	<b>PROTECTEUR</b> SCHUTZ PROTECTOR PROTECTOR PROTEZIONE
64	75 491 948	01	-(D) -(DK) -(A) -(I)	11/79 ▶ 11/79 ▶ 07/81 ▶	<b>COUVERCLE</b> ABDECKUNG GAUGE WELL COVR TAPA TUBO BUJIA COPERCHIO

**XT**

15/02/91 1117 02-3120-10 PAGE : 1 D11 ↓	<b>EMBRAYAGE</b> KUPPLUNG CLUTCH EMBRAGUE FRIZIONE		03	95 616 712	01 15X56X17	<b>BUTEE DEBRAYAGE</b> LAGER BEARING BUFFER TOPE EMBRAGUE CUSCINETTO	
			04	AM 314 4 C	01 LON 47	<b>FOURCHETTE</b> GABEL CLUTCH FORK HOROUILLA FORCELLA	
			05	AM 314 9	01	<b>RESSORT</b> RUCKZUGFEDER RETURN SPRING MUELLE MOLLA RICHIAMO	
			06	75 527 611	01 DIAM9 LON 126	<b>AXE DE LEVIER</b> HEBELBOLZEN LEVER PIN EJE PALANCA PERNO LEVA	
			07	95 633 279	01 -NYLON- 9X11X33 RMP GX0811801A	<b>AGRAFE DE BUTEE</b> LAGERSPANGE STOP CLIP GRAPA TOPE EMBR AGRAFE RALLA	
			08	75 420 178	02 9X11X33	<b>BAGUE ELASTIQUE</b> RING BUSHING CASQUILLO ELAS BOCCOLA ELAST	
1114 23120100 ► 1977			09	79 03 007 094	01 4X0.70-16	<b>VIS TCB</b> SCHRAUBE CAPSCREW TORNILLO TCB VITE	
01	AY 8312 000	01 PKH 85	<b>MECANISME EMBR.</b> DRUCKPLATTE CLUTCH MECHANIM MECANISMO MECCANISMO	10	79 03 201 020	06 DIAM 6X1.00-12	<b>VIS TH</b> SCHRAUBE CAPSCREW TORNILLO TH VITE
02	75 492 217	01 DIAM 155 RMP AY31301 - 95494133	<b>FRICITION</b> KUPPL SCHEIBE CLUTCH PLATE DISCO EMBRAGUE FRIZIONE	11	95 559 036	01 "PAM" RMP 95559054	<b>KIT PRO EMBRAY.</b> KUPPLUNGSSATZ CLUTCH KIT PRO KIT PRO EMBRAGU INSIEME FRIZION



702/91  
17 02-3121-10  
AGE : 1  
10 ↓

**EMBRAYAGE CENTRIFUGE**  
FLIEHKRAFTKUPPLUNG  
CENTRIFUGAL CLUTCH  
EMBRAGUE CENTRIFUGO  
FRIZIONE CENTRIFUGA

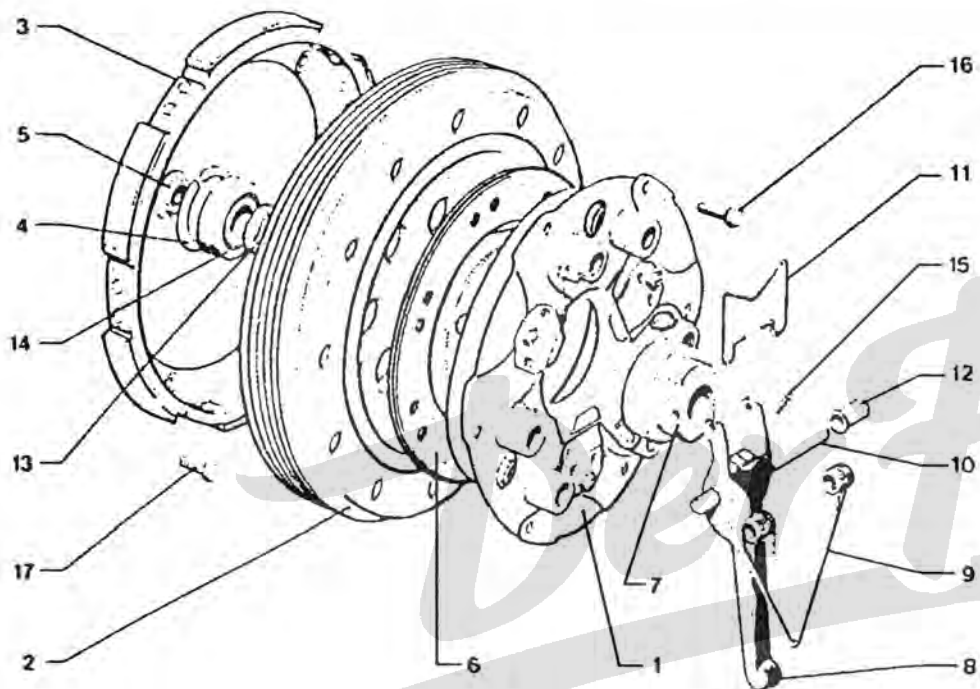

1114

2-312-20  
Z3121100

► 2425

AY 8312 000

01 PKH 85

MECANISME EMBR.  
DRUCKPLATTE  
CLUTCH MECHANIM  
MECANISMO  
MECCANISMO

AM 312 01 A

01

TAMBOUR EMBRAY.  
TROMMEL  
CLUTCH DRUM  
TAMBOR EMBRAGUE  
TAMBURO FRIZ

03	AM 312 7 D	01	COURONNE DEMAR. ZAHNKRANZ START RING GEAR CORONA ARRANQUE CORONA
04	AZ 312 87	01	DIAM 42-E 1,7 SEGMENT D'ARRET HALTEERING STOP RING SEGMENTO RETEN. ANELLO ARRESTO
05	AZ 332 5	01	HE 16X1,50 ECROU MUTTER NUT TUERCA DADO
06	75 492 217	01	DIAM 155 RMP AY31301 - 95494133 FRICTION KUPPL.SCHEIBE CLUTCH PLATE DISCO EMBRAGUE FRIZIONE
07	95 616 712	01	15X56X17 BUTEE DEBRAYAGE LAGER BEARING BUFFER TOPE EMBRAGUE CUSCINETTO
08	AM 314 4 C	01	LON 47 FOURCHETTE GABEL CLUTCH FORK HOROUILLA FORCELLA
09	AM 314 9	01	RESSORT RUCKZUGFEDER RETURN SPRING MUELLE MOLLA RICHIAMO
10	75 527 611	01	DIAM9 LON 126 AXE DE LEVIER HEBELBOLZEN LEVER PIN EJE PALANCA PERNO LEVA
11	95 633 279	01	-NYLON- 9X11X33 RMP GX0811801A AGRAFE DE BUTEE LAGERSPANGE STOP CLIP GRAPA TOPE EMBR AGRAFE RALLA

.../...

15/02/91  
1117 02-3121-10  
PAGE : 2  
D09 ↓

**EMBAYAGE CENTRIFUGE**  
FLIEHKRAFTKUPPLUNG  
CENTRIFUGAL CLUTCH  
EMBRAGUE CENTRIFUGO  
FRIZIONE CENTRIFUGA

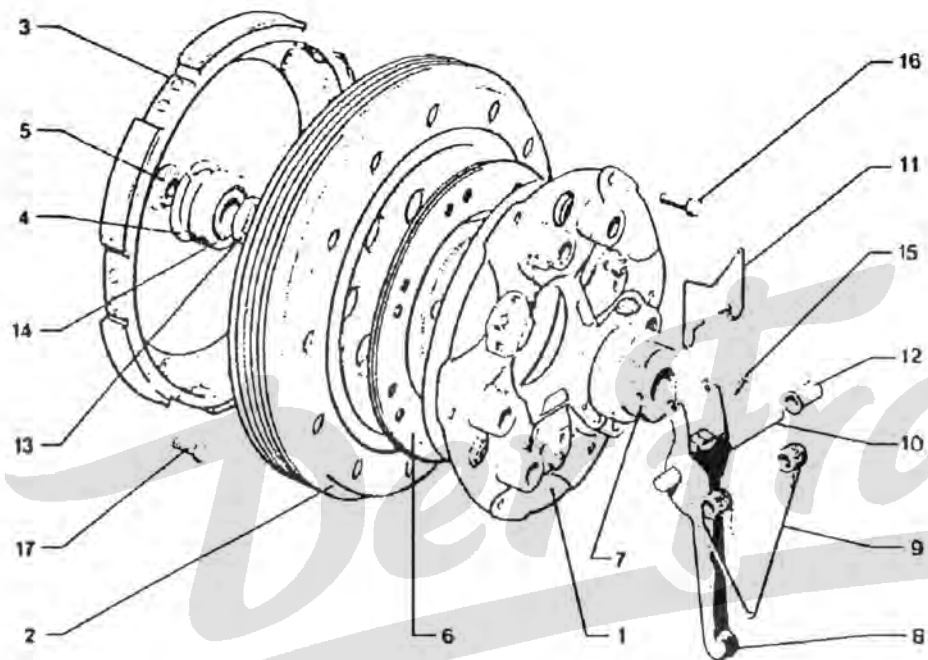

1114

2-312-20  
23121100

► 2425

12	75 420 178	02	9X11X33	BAGUE ELASTIQUE RING BUSHING CASQUILLO ELAS BOCCOLA ELAST
13	AZ 332 99	01	DIAM 17X22 E 2.5	ENTRETOISE ABSTANDSSTUECK SPACER JUEGO DISTANCIA DISTANZIALE
	AZ 332 99 A	01	DIAM 17X22 E 2.8	-
	AZ 332 99 B	01	DIAM 17X22 E 3.1	-

13	AZ 332 99 C	01	DIAM 17X22 E 3.4	ENTRETOISE ABSTANDSSTUECK SPACER JUEGO DISTANCIA DISTANZIALE
	AZ 332 99 D	01	DIAM 17X22 E 3.7	-
	AZ 332 99 E	01	DIAM 17X22 E 4	-
14	26 201 039	01	AV 40X17X12	ROULEMENT LAGER ALTERN BEARING RODAMIENTO CUSCINETTO
15	79 03 007 094	01	4X0.70-16	VIS TCB SCHRAUBE CAPSCREW TORNILLO TCB VITE
16	79 03 201 020	06	DIAM 6X1.00-12	VIS TH SCHRAUBE CAPSCREW TORNILLO TH VITE
17	26 210 269	05	DIAM 7X9 2	-

15/02/91  
 1117 02-3124-10  
 PAGE : 1  
 D08 ↓

**EMBRAYAGE A DIAPHRAGME**  
 KUPPLUNG MIT FEDERSCHEIBE  
 CLUTCH WITH DIAFRAGME  
 EMBRAGUE A DIAFRAGMA  
 FRIZIONE A DIAFRAMMA

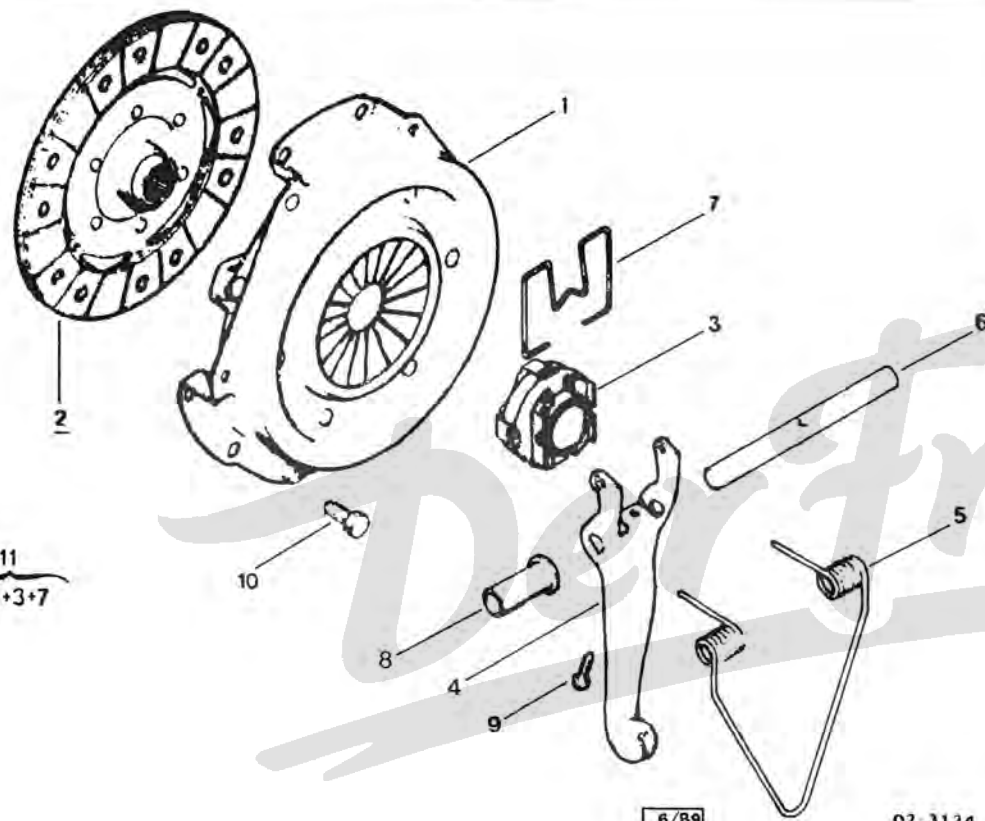

1117

6/89

02 3124 10

Z3124100

1978 ▶

01	<b>95 635 352</b>	01 RMP 75492572	<b>MECANISME EMBR.</b> DRUCKPLATTE CLUTCH MECHANIM MECANISMO MECCANISMO
02	<b>96 034 551</b>	01 RMP 95495173	<b>FRICITION</b> KUPPL SCHEIBE CLUTCH PLATE DISCO EMBRAGUE FRIZIONE

03	<b>95 494 929</b>	01	<b>BUTEE DEBRAYAGE</b> LAGER BEARING BUFFER TOPE EMBRAGUE CUSCINETTO
04	<b>AM 314 4 C</b>	01 LON 47	<b>FOURCHETTE</b> GABEL CLUTCH FORK HOROUILLA FORCELLA
05	<b>AM 314 9</b>	01	<b>RESSORT</b> RUCKZUGFEDER RETURN SPRING MUELLE MOLLA RICHIAMO
06	<b>75 527 611</b>	01 DIAM 9 LON 126	<b>AXE DE LEVIER</b> HEBELBOLZEN LEVER PIN EJE PALANCA PERNO LEVA
07	<b>95 633 279</b>	01 -NYLON- 9X11X33 RMP 95576819	<b>AGRAFE DE BUTEE</b> LAGERSPANGE STOP CLIP GRAPA TOPE EMBR AGRAFE RALLA
08	<b>75 420 178</b>	02 9X11X33	<b>BAGUE ELASTIQUE</b> RING BUSHING CASQUILLO ELAS BOCCOLA ELAST
09	<b>79 03 007 094</b>	01 4X0,70-16	<b>VIS TCB</b> SCHRAUBE CAPSCREW TORNILLO TCB VITE
10	<b>79 03 101 769</b>	01 DIAM 7X45	<b>VIS TH</b> SCHRAUBE CAPSCREW TORNILLO TH VITE
11	<b>95 650 913</b>	01 RMP 95584419	<b>KIT PRO EMBRAY.</b> KUPPLUNGSSATZ CLUTCH KIT PRO KIT PRO EMBRAGU INSIEME FRIZION

.../...

15/02/91  
1117 02-3124-10  
PAGE : 2  
D07 ↓

**EMBRAYAGE A DIAPHRAGME**  
KUPPLUNG MIT FEDERSCHEIBE  
CLUTCH WITH DIAFRAGME  
EMBRAGUE A DIAFRAGMA  
FRIZIONE A DIAFRAMMA

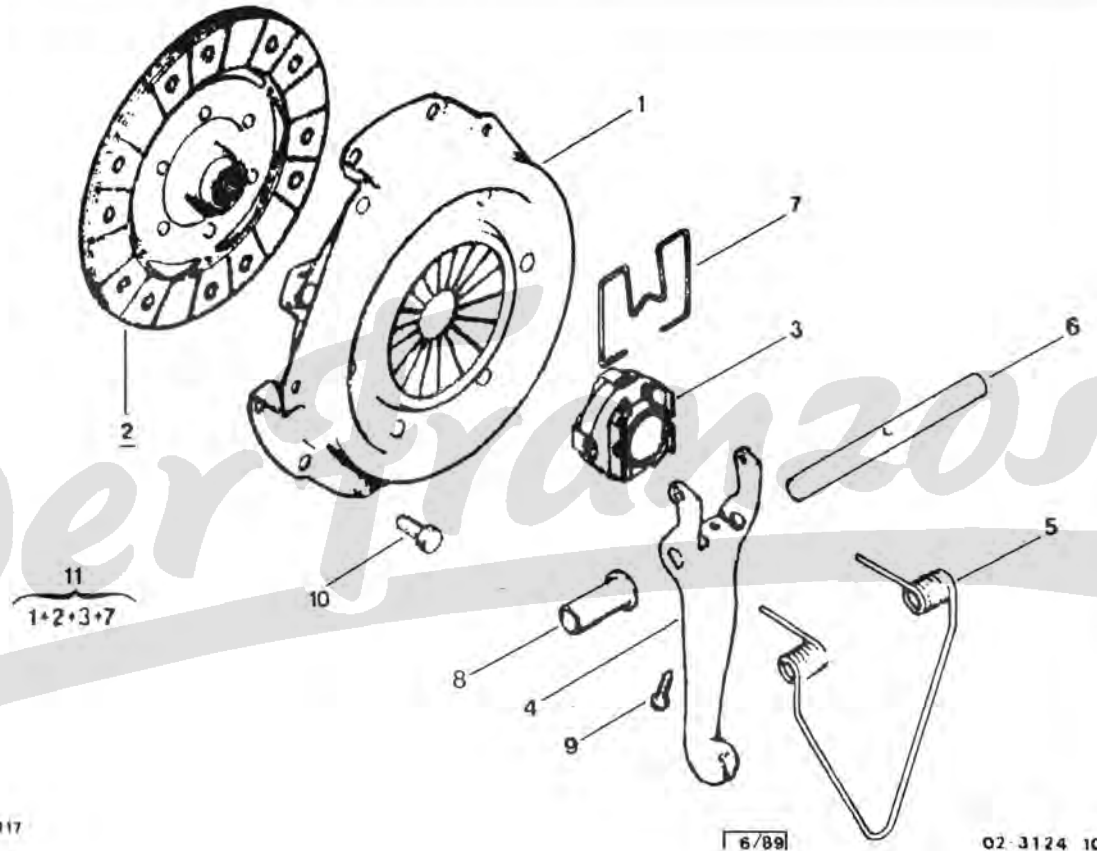

1117

6/89

02-3124 10

Z3124100

1978 ▶

52	96 034 551	01 -(D)	<b>XT</b>	<b>FRICION</b> KUPPL SCHEIBE CLUTCH PLATE DISCO EMBRAGUE FRIZIONE
----	------------	---------	-----------	---

15/02/91  
 1117 02-5320-10  
 PAGE :1  
 D06 ↓

**ALTERNATEUR**  
 WECHSELSTROMGENERATOR  
 ALTERNATOR  
 ALTERNADOR  
 ALTERNATORE

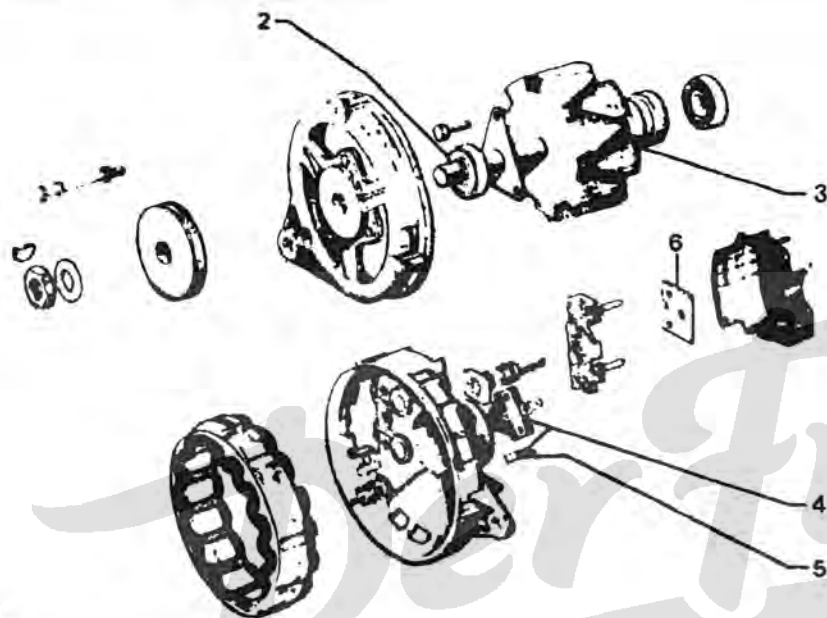

1  
 DUCELLIER

1117

6/89

02-5320-10

Z5320100

**DUCELLIER 7532 E**

- LES PIECES NON REPEREES SONT N F P

01	<b>5 473 145</b>	01 RMP 95492810	<b>ALTERNATEUR NE</b> LIMA NEU ALTERNATOR NEW ALTERNADOR NE ALTERNAT NUOVO
02	<b>AY 9532 995 A</b>	01 AV-15X25X11 RMP AY9532145A	<b>ROULEMENT</b> LAGER ALTERNAT BEARING RODAMIENTO CUSCINETTO

03	<b>95 535 483</b>	01	<b>AVEC ROULEMENT</b> <b>ROTOR</b> ROTOR ALTERNATR ROTOR ROTOR ROTORE
04	<b>AY 532 11</b>	01	<b>PORTE-BALAIS</b> KOHLENTRAEGER ALT BRUSH-HOLDR PORTA ESCOBILLA PORTASPAZZOLA
05	<b>AY 532 013</b> NFP	01	<b>JEU DE BALAIS</b> KOHLENSATZ ALT BRUSH SET JUEGO ESCOBILL SERIE SPAZZOLE
06	<b>AY 532 62</b>	01	<b>FUSIBLE</b> SICHERUNG FUSE FUSIBLE FUSIBILE

15/02/91  
1117 02-5320-20  
PAGE : 1  
D05 ↓

**ALTERNATEUR**  
WECHSELSTROMGENERATOR  
ALTERNATOR  
ALTERNADOR  
ALTERNATORE

PARIS-RHONE

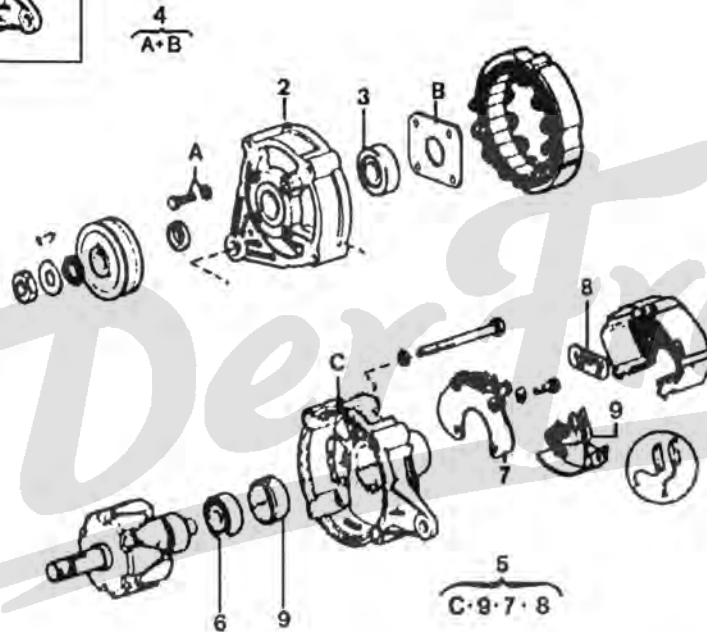
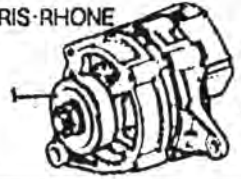

1117

8/89

02-5320-20  
Z5320200

PARIS RHONE A 11 M 12

- LES PIECES NON REPEREES SONT N F P

01	5 473 145	01	RMP 5446248	ALTERNATEUR NE LIMA NEU ALTERNATOR NEW ALTERNADOR NE ALTERNAT NUOVO
02	5 446 242	01	AV AVEC ROULEMENT	PALIER AV LAGERDECKEL V. ALT FRT BEARING TAPA DELANTERA SUPPORTO ANTER.

03	AY 9532 995 A	01	AV-15X25X11	ROULEMENT LAGER ALTERN BEARING RODAMIENTO CUSCINETTO
04	5 446 245 NFP	01		JEU DE PIECES TEILESATZ ALTERN PART SET JUEGO DE PIEZAS SERIE PEZZI
05	5 446 244 NFP	01		PALIER LAGER BEARING CASQUILLO CUSCINETTO
06	AY 9532 995 B	01	10X26-8	ROULEMENT LAGER BEARING RODAMIENTO CUSCINETTO
07	GX 11 160 01A	01		SUPPORT DIODES DIODENTRAEGER DIODE SUPPORT PLACA DIODOS SUPPORTO DIODI
08	AY 532 62 A	01		FUSIBLE SICHERUNG FUSE FUSIBLE FUSIBILE
09	GX 11 154 01A	01		PORTE-BALAIS KOHLENTAERGER ALT BRUSH-HOLDER PORTA ESCOBILLA PORTASPAZZOLA
10	5 485 839	01		JEU DE BALAIS KOHLENSATZ ALT BRUSH SET JUEGO ESCOBILLA SERIE SPAZZOLE
11	AY 9532 912 L	01		JEU DE PIECES TEILESATZ ALTERN PART SET JUEGO DE PIEZAS SERIE PEZZI

15/02/91  
 1117 02-5320-30  
 PAGE : 1  
 D04 ↓

**ALTERNATEUR**  
 WECHSELSTROMGENERATOR  
 ALTERNATOR  
 ALTERNADOR  
 ALTERNATORE

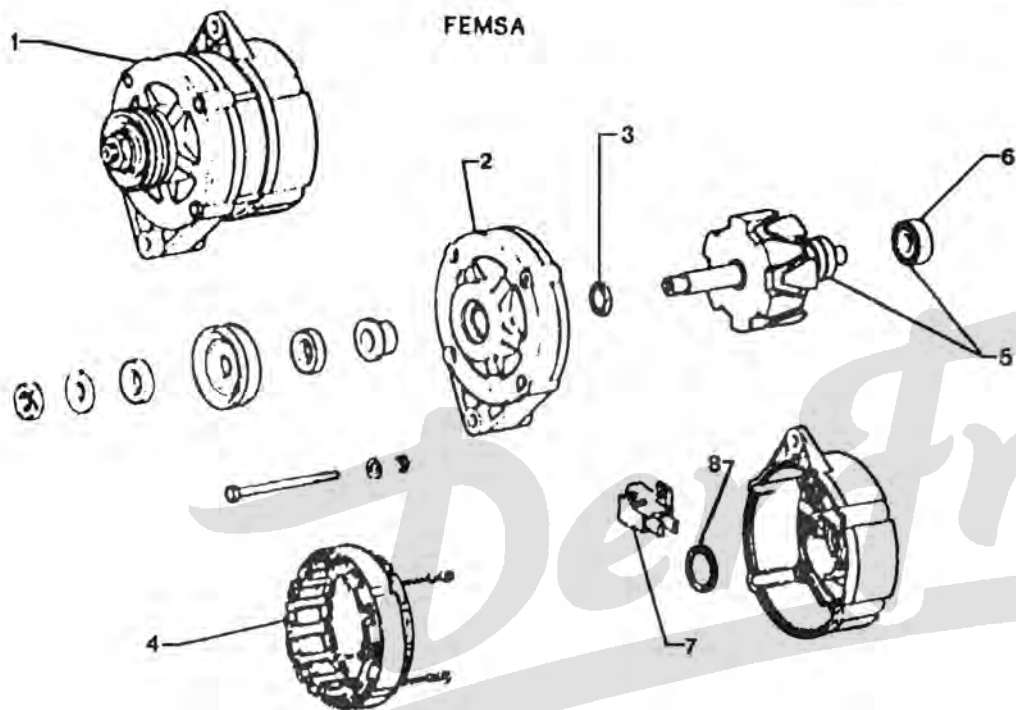

1117 6/89 02-5320-30  
 Z5320300

**FEMSA ALN 12-1**

**- LES PIECES NON REPEREES SONT NFP**

01	5 473 145	01	RMP 5490438	ALTERNATEUR NE LIMA NEU ALTERNATOR NEW ALTERNADOR NE ALTERNAT NUOVO
02	5 471 236	01		PALIER AV LAGERDECKEL V. ALT FRT BEARING TAPA DELANTERA SUPPORTO ANTER.

03	95 471 709 NFP	01	AV	BAGUE DE PALIER LAGERHUELSE BEARING BUSH CASQUILLO BOCCOLA SUPPORT
04	5 471 238	01		STATOR STATOR ALTERNAT STATOR ESTATOR ALTERN. STATORE
05	5 471 237	01		ROTOR ROTOR ALTERNATR ROTOR ROTOR ROTORE
06	94 05 724 138	01	13X32-10 RMP 95471240	ROULEMENT LAGER ALTERN BEARING RODAMIENTO CUSCINETTO
07	5 471 241	01		PORTE-BALAIS KOHLENTRAEGER ALT BRUSH-HOLDER PORTA ESCOBILLA PORTASPAZZOLA
08	95 480 020	01	DIAM INT 3,4E1,8 CAOUTCHOUC	JEU DE PIECES TEILESATZ ALTERN PART KIT JUEGO DE PIEZAS SERIE PEZZI

15/02/91  
 1117 02-5320-40  
 PAGE : 1  
 D03 ↓

**ALTERNATEUR**  
 WECHSELSTROMGENERATOR  
 ALTERNATOR  
 ALTERNADOR  
 ALTERNATORE

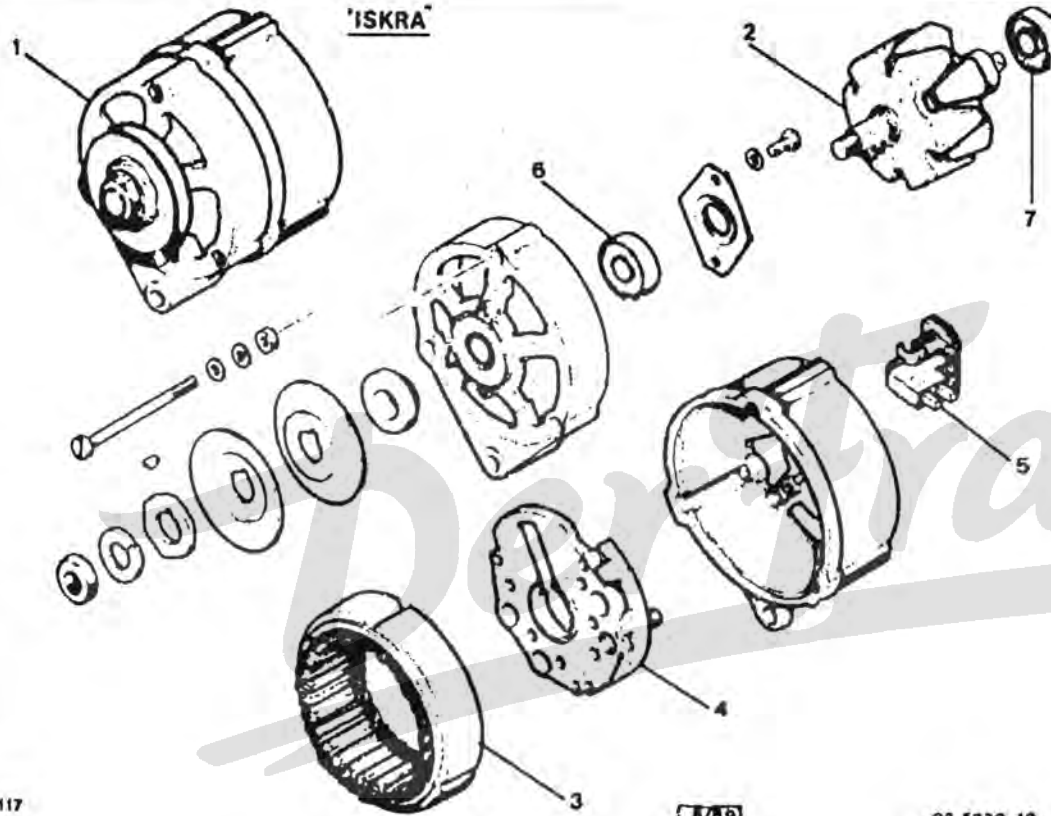

1117

[8/89]

02.5320-40  
 Z5320-400

**ISKRA AAG 0702**

- LES PIECES NON REPEREES SONT NFP

01	5 473 145	01	RMP 75491667	ALTERNATEUR NE LIMA NEU ALTERNATOR NEW ALTERNADOR NE ALTERNAT NUOVO
02	75 512 014	01		ROTOR ROTOR ALTERNATR ROTOR ROTOR ROTORE

03	75 512 015 NFP	01		STATOR STATOR ALTERNAT STATOF ESTATOR ALTERN. STATORE
04	75 512 012 RP 95580160	01	▶ 4008	BLOC REDRESSEUI GLEICHRICHTER DIODE PLATE PLACA BLOCCO RADDRIZ:
	95 646 202	01	ENS	-
05	75 512 011	01		PORTE-BALAIS KOHLENTRAEGER ALT BRUSH-HOLDI PORTA ESCOBILLA PORTASPAZZOLA
06	26 201 039	01	AV 40X17X12 07/79 ▶ 4004	ROULEMENT LAGER ALTERNAT BEARING RODAMIENTO CUSCINETTO
	95 646 200 NFP	01	▶ 4005	-
07	26 203 169	01	AR-12X32X10 ▶ 4000	-
	95 646 201	01	ENS ▶ 4035	-



15/02/91  
1117 02-5324-10  
PAGE : 1  
D02 ↓

**ALTERNATEUR - FIXATION COURROIE**  
WECHSELTRONGENERATOR-KEIRIEMENBETESTGG  
ALTERNATOR - BELT FASTENING  
ALTERNADOR-FIJACION CORREA  
ALTERNATORE-FISSAGGIO CINGHIA

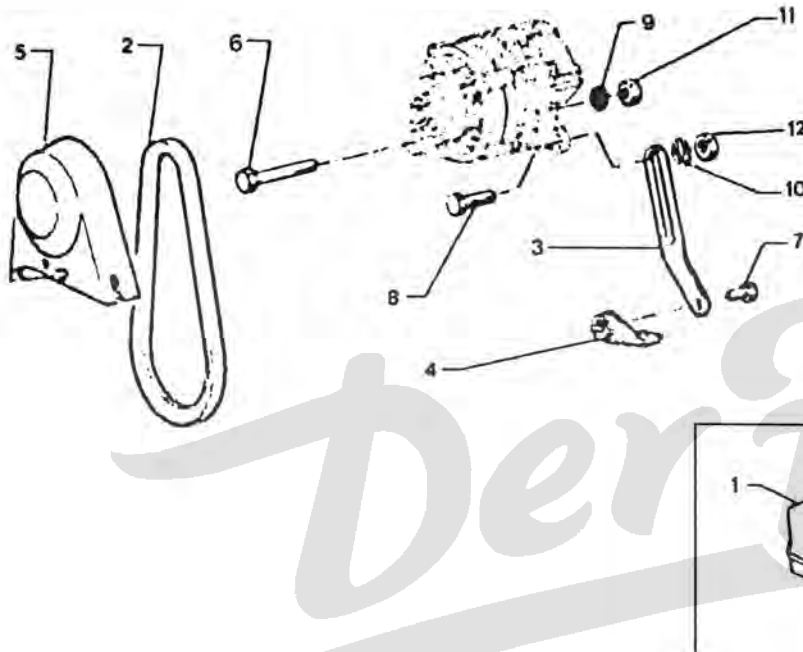

1114

2 532 10

Z5324100

01	5 501 011	01	RMP GX1110901A-GX1110902A-549150%	▶ 06/80	REGULATEUR REGLER ALTERN REGULATR REGULADOR REGOLATORE
02	AY 532 17	01	LON 755	▶ 4495	COURROIE ALTER. KEILRIEMEN ALTERNATOR BELT CORREA ALTERNA CINGHIA

02	91 536 302	01	LON 765 4496 ▶	COURROIE RIEMEN BELT CORREA CINGHIA
03	75 526 182	01		PATTE STREBELASCHE TENSION LUG SOPORTE STAFFA
04	75 526 180	01	1 DIAM 7X1,00	PATTE SUPPORT HALTELASCHE SUPPORT BRACKET SOP.ALTERNADOR STAFFA SUPPORTO
05	95 534 707	01		CAPOT ALTERNAT. DECKEL ALTERNATOR CAP PROTECTOR COPERCHIO
06	23 871 019	01	DIAM 9X1,25-105 RMP 23872019	VIS TH SCHRAUBE CAPSCREW TORNILLO TH VITE
07	23 464 319	01	DIAM 7X22	-
08	79 03 001 708	01	DIAM 7X1,00-20	-
09	79 03 056 125	01	DIAM 9,5X16,5	RONDELLE GROWER GROWERSCHEIBE SPRING WASHER ARANDELA RONDELLA GROWER
10	79 03 058 011	02	DIAM 7,2X14,2-1,4	RONDELLE CONIQU KONUSSCHFIBE SPRING WASHER ARANDELA RONDELLA CONICA
11	25 243 019 RP 95623753	01	DIAM 9X1,25-7,5	ECROU HEXAGONAL SECHSKANTMUTTER HEXAGONAL NUT TUERCA DADO ESAGONALE
12	79 03 032 036	02	HE 7X1,00-5,5	ECROU MUTTER NUT TUERCA DADO

15/02/91  
1117 02-5330-10  
PAGE : 1  
D01 →

**DEMARREUR**  
ANLASSER  
STARTER  
MOTOR DE ARRANQUE  
MOTORINO AVVIAMENTO

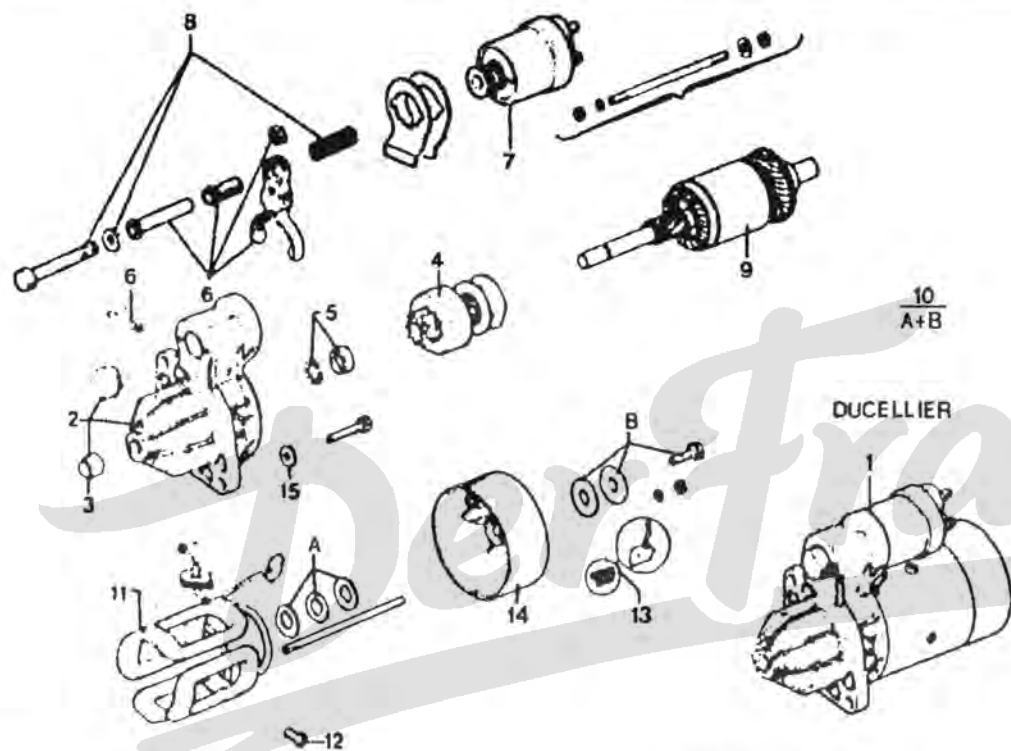

1117

6/89

02.5330.10  
Z5330100

**DUCELLIER**

- LES PIECES NON REPEREES SONT N F P

01	5 473 630	01	RMP 95494247-75491723-62020-6202D-620E	DEMARREUR NEUF ANLASSER NEU STRT-MOTOR NEW MOT ARRANQ. NE MOTOR.AVV.NUOVO	03	95 618 271 RP 95618194	01	ENS RMP DM9533002L	JEU COUSSINETS SATZ LAGER BEARING SET JUEGO COJINETES SERIE CUSCINET
02	5 469 499 NFP	01		PALIER AV LAGERDECKEL V. FRONT BEARING TAPA DELANTERA SUPPORTO ANTER.	04	AM 533 248 A	01		LANCEUR MAGNETSCHALTER STRTR-MOT DRIVE PINON ARRASTRE PIGNONE MOT AVV
					05	DV 9533 267 A	01	FNS	BUTEE LANCEUR ANSCHLAG SOLENOID BUFFER TOPE DEL LANZAD CUSCINETTO
					06	5 430 262 NFP	01	ENS	AXE DE FOURCHE. GABELACHSE FORK PIN EJE HORQUILLA PERNO FORCELLA
					07	5 469 497	01	6202 C-D	SOLENOIDE MAGNETSCHALTER SOLENOID SOLENOIDE MOT A SOLENOIDE
					08	AM 533 031 A	01	6202 F	-
					08	5 486 547	01	6202F RMP 7901583320	JEU DE PIECES TEILESATZ SOLEN PART SET JUEGO DE PIEZAS SERIE PEZZI
					09	5 469 533	01		INDUIT ANKER STRTR MOT ARMAT INDUCIDO INDOTTO
					10	5 486 799	01	ENS RMP 5469503	JEU DE PIECES TEILESATZ BRAKG PART SET JUEGO DE PIEZAS SERIE PEZZI
					11	5 469 496 NFP	01	ENS	INDUCTEURS ERREGERWICKLUNG FIELD COIL BOBINAS INDUCTO INDICATORE

.../...

15/02/91  
 1117 02-5330-10  
 PAGE : 2  
 E01 ↑

**DEMARREUR**  
**ANLASSER**  
**STARTER**  
**MOTOR DE ARRANQUE**  
**MOTORINO AVVIAMENTO**

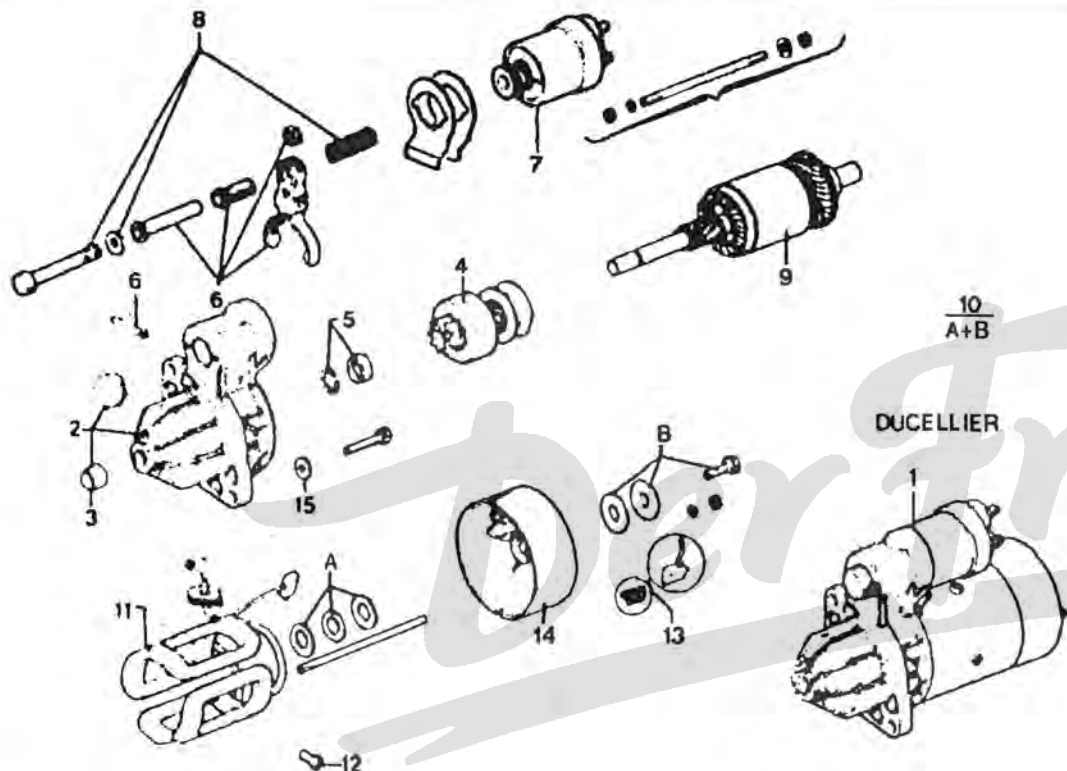

1117

6/89

02.5330.10  
 Z5330100

**DUCELLIER**

2	95 619 609	04	ENS	<b>VIS DE MASSE</b> P-SCHUHSCHRAUBE POLE SHOE SCREW TORNILLO MASA VITE MASSA POL.
3	5 469 534	01	ENS	<b>JEU DE BALAIS</b> KOHLENSATZ BRUSH SET JUEGO ESCOBILL SERIE SPAZZOLE

14	75 512 846 NFP	01	▶ 11/79	<b>PALIER AR</b> LAGERDECKEL H. REAR BEARING TAPA TRASERA SUPPORTO POSTER
	5 469 500	01	12/79 ▶	-
15	79 03 058 011	02	DIAM 7.2X14.2-1,4	<b>RONDELLE CONIQU</b> KONUSSCHEIBE SPRING WASHER ARANDELA RONDELLA CONICA

15/02/81  
 1117 02-5330-20  
 PAGE : 1  
 E02 ↑

**DEMARREUR**  
 ANLASSER  
 STARTER  
 MOTOR DE ARRANQUE  
 MOTORINO AVVIAMENTO

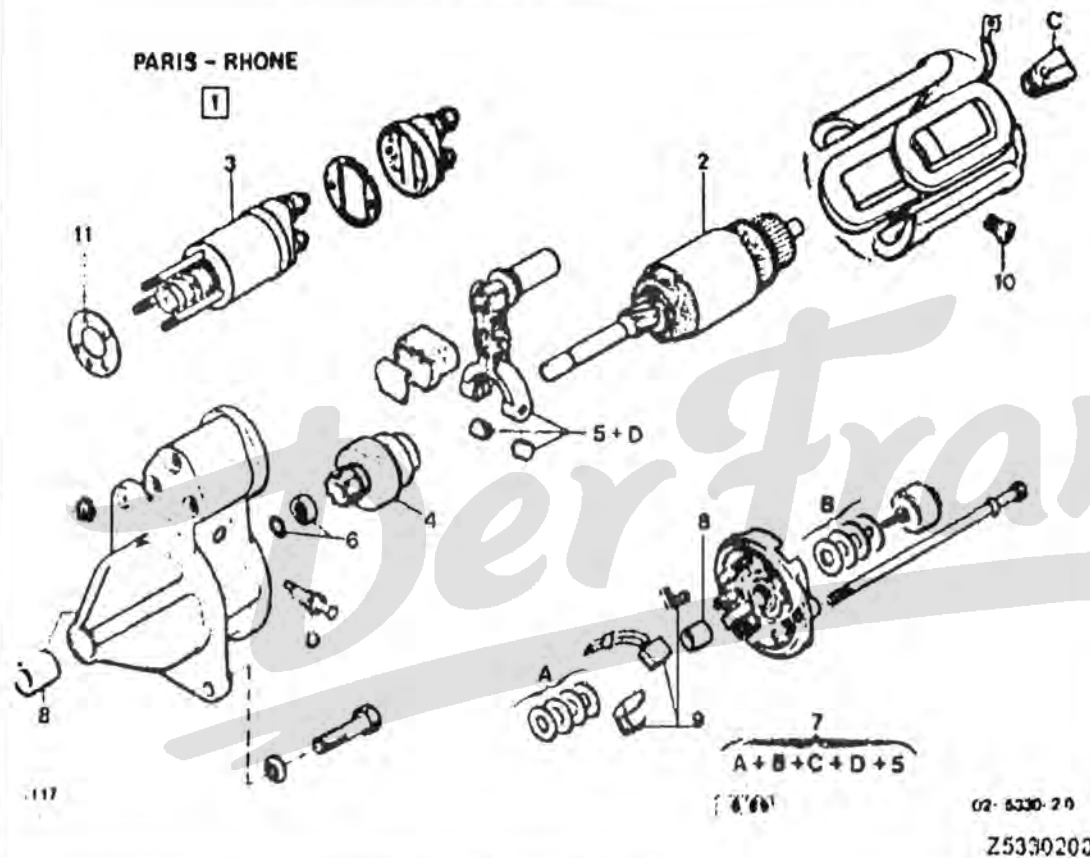

PARIS RHONE D 8 E 148

- LES PIECES NON REPEREES SONT NFP

01	5 473 630	01	RMP 75492566	DEMARREUR NEUF ANLASSER NEU STRT-MOTOR NEW MOT ARRANO NE MOTOR AVV.NUOVO
02	75 530 276	01		INDUIT ANKER STRTR MOT ARMAT INDUCIDO INDOTTO

03	77 01 022 169	01		CONTACTEUR STECKVERBINDER CONTACT SWITCH CONTACTOR CONTATTORE
04	75 530 281	01	RA 46 G	LANCEUR MAGNETSCHALTER STRTR-MOT DRIVE FINON ARRASTRE PIGNONE MOT.AVV
05	95 618 201	01	ENS	FOURCHETTE GABEL START-MOT FORK HORQUILLA FORCELLA
06	DV 533 012	01	ENS	BUTEE LANCEUR ANSCHLAG SOLENOID BUFFER TOPE DEL LANZAD CUSCINETTO
07	95 618 206	01	ENS	NEC REPARATION REPARATURSATZ REPAIR KIT NECESER OCCORRENTE RIP
08	95 618 193	01	ENS	COUSSINET LAGERBUCHSE COVER BEARING COJINETE CUSCINETTO
09	95 618 180	01	ENS	BALAI DEMARREUR ANLASSERKOHLE START-MOT BRUSH ESCOBILLA SPAZZOLA AVVIAM
10	94 05 816 118	04		VIS DE MASSE P-SCHUHSCHRAUBE POLE SHOE SCREW TORNILLO MASA VITE MASSA POL
11	DX 533 131 A	01		JOINT CAOUTCHOU GUMMIDICHTUNG RUBBER SEAL JUNTA GOMA GUARNIZIONE GOM

15/02/91  
1117 02-5330-25  
PAGE : 1  
E03 ↑

**DEMARREUR**  
ANLASSER  
STARTER  
MOTOR DE ARRANQUE  
MOTORINO AVVIAMENTO

PARIS - RHONE

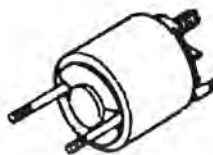
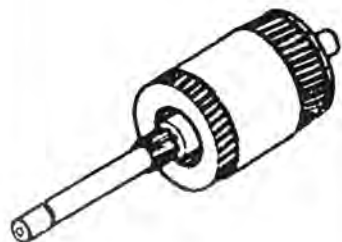
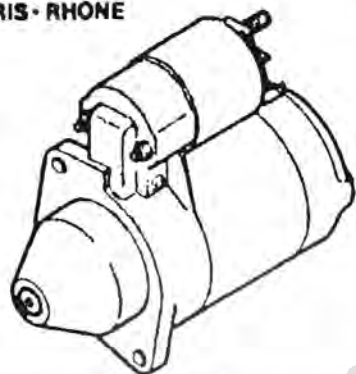

1116

04,27

2.533.21  
Z5330250

PARIS RHONE D 9 E 93

01 95 618 773

01

DEMARREUR NEUF  
ANLASSER NEU  
STRT-MOTOR NEW  
MOT ARRANQ. NE  
MOTOR.AVV.NUOVO

02 95 619 468

01

INDUIT  
ANKER  
STRTR MOT ARMAT  
INDUCIDO  
INDOTTO

03

95 588 211

01

SOLENOIDE  
MAGNETSCHALTER  
SOLENOID  
SOLENOIDE MOT A  
SOLENOIDE

04

95 619 469

01

LANCEUR  
MAGNETSCHALTER  
STRTR-MOT DRIVE  
PINON ARRASTRE  
PIGNONE MOT.AVV

05

95 618 200

01 ENS

FOURCHETTE  
CABEL  
START-MOT FORK  
HOROUILLA  
FORCELLA

06

75 526 989

01 ENS

BUTEE LANCEUR  
ANSCHLAG  
SOLENOID BUFFER  
TOPE CEL LANZAD  
CUSCINETTO

07

95 618 207

01 ENS

NEC REPARATION  
REPARATURSATZ  
REPAIR KIT  
NECESER  
OCCORRENTE RIP.

08

95 618 194

01 ENS

JEU COUSSINETS  
SATZ LAGER  
BEARING SET  
JUEGO COJINETES  
SERIE CUSCINET.

09

95 618 183

01 ENS

BALAI DEMARREUR  
ANLASSERKOHLE  
START-MOT BRUSH  
ESCOBILLA  
SPAZZOLA AVVIAM

10

94 05 816 118

01

VIS DE MASSE  
P-SCHUHSCHRAUBE  
POLE SHOE SCREW  
TORNILLO MASA  
VITE MASSA POL.



**DEMARREUR**  
 ANLASSER  
 STARTER  
 MOTOR DE ARRANQUE  
 MOTORINO AVVIAMENTO

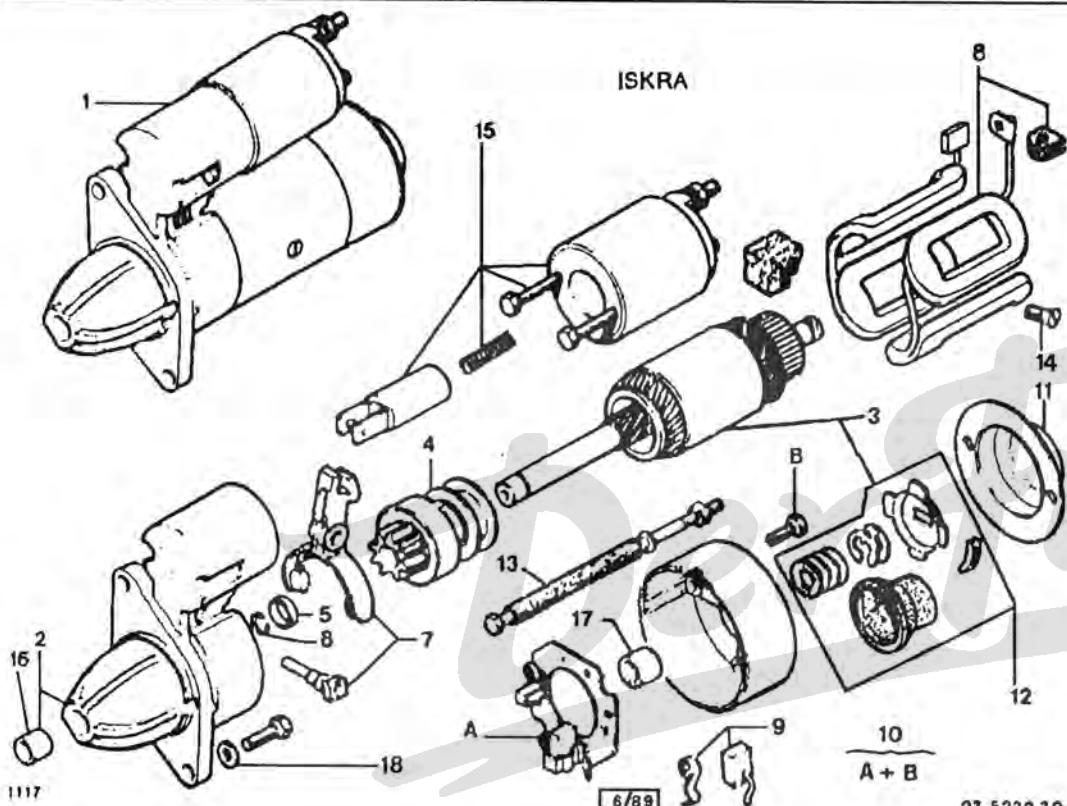

02.5330.30  
 Z5330300

**ISKRA AZE 0305**

5 507 126  
 RP 95646218

01 ENS

JEU DE PIECES  
 TEILESATZ  
 BRAGK PART SET  
 JUEGO DE PIEZAS  
 SERIE PEZZI

95 646 218

01 ENS  
 RMP 5507131

5 507 120  
 RP 95580166

04 ENS  
 RMP 5507121

INDUCTEURS  
 ERREGERWICKLUNG  
 FIELD COIL  
 BOBINAS INDUCTO  
 INDICATORE

15	5 507 119	01		SOLENOIDE MAGNETSCHALTER SOLENOID SOLENOIDE MOT A SOLENOIDE
16	95 546 010 NFP	01	AV	BAGUE CENTRAGE ZENTRIERRING CENTRING RING CASQUILLO CENT BOCCOLA CENTRAG
17	95 646 215	01	RMP 95546011	-
18	79 03 058 011	01	DIAM 7,2X14,2-1,4 07/79 ▶	RONDELLE CONIQU KONUSSCHEIBE SPRING WASHER ARANDELA RONDELLA CONICA

15/02/91  
1117 02-5330-40  
PAGE : 1  
E06 ↑

**DEMARREUR**  
ANLASSER  
STARTER  
MOTOR DE ARRANQUE  
MOTORINO AVVIAMENTO

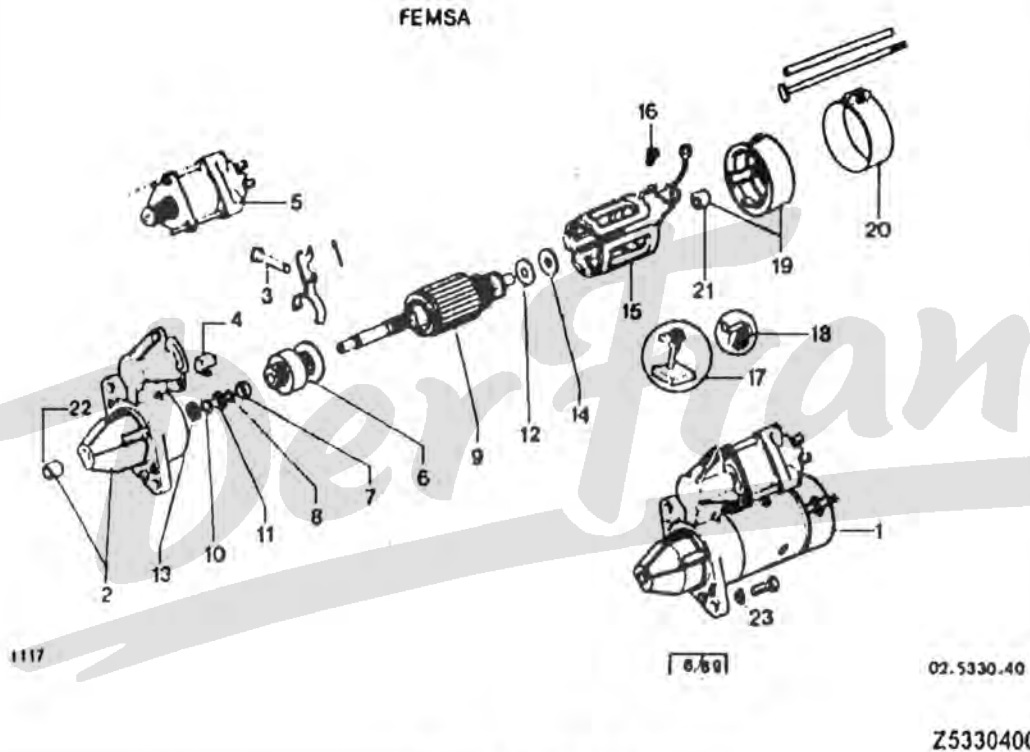

FEMSA MTA 12-30  
▶ 2641

- NOTA:LES PIECES NON REFERENCEES SONT NFP

01	5 473 630	01	RMP 5426014	DEMARREUR NEUF ANLASSER NEU STRT-MOTOR NEW MOT ARRANQ. NE MOTOR.AVV.NUOVO
02	5 444 736	01	AV	PALIER AV LAGERDECKEL V. FRONT BEARING TAPA DELANTERA SUPPORTO ANTER.

03	5 444 738	01	AXE DE FOURCHE. GABELACHSE FORK PIN EJE HORQUILLA PERNO FORCELLA
04	5 444 739	01	SUPPORT HALTER SWITCH BRACKET SOPORTE SUPPORTO
05	5 444 740	01	CONTACTEUR STECKVERBINDER CONTACT SWITCH CONTACTOR CONTATTORE
06	5 444 741	01	LANCEUR MAGNETSCHALTER STRTR-MOT DRIVE PINON-ARRASTRE PIGNONE MOT.AVV
07	5 444 742	01	COUSSINET LAGERBUCHSE SOLENOID BEARG COJINETE CUSCINETTO
08	5 444 743	01	BUTEE LANCEUR ANSCHLAG SOLENOID BUFFER TOPE DEL LANZAD CUSCINETTO
09	5 444 744	01	INDUIT ANKER STRTR MOT ARMAT INDUCIDO INDOTTO
10	5 450 095	01	JEU DE PIECES TEILESATZ SOLEN PART KIT JUEGO DE PIEZAS SERIE PEZZI
11	5 444 745	01	-
12	5 444 747	01	-
13	5 444 746	01	-

.../...



15/02/91  
 1117 02-5330-40  
 PAGE : 2  
 E07 ↑

**DEMARREUR**  
**ANLASSER**  
**STARTER**  
**MOTOR DE ARRANQUE**  
**MOTORINO AVVIAMENTO**

FEMSA

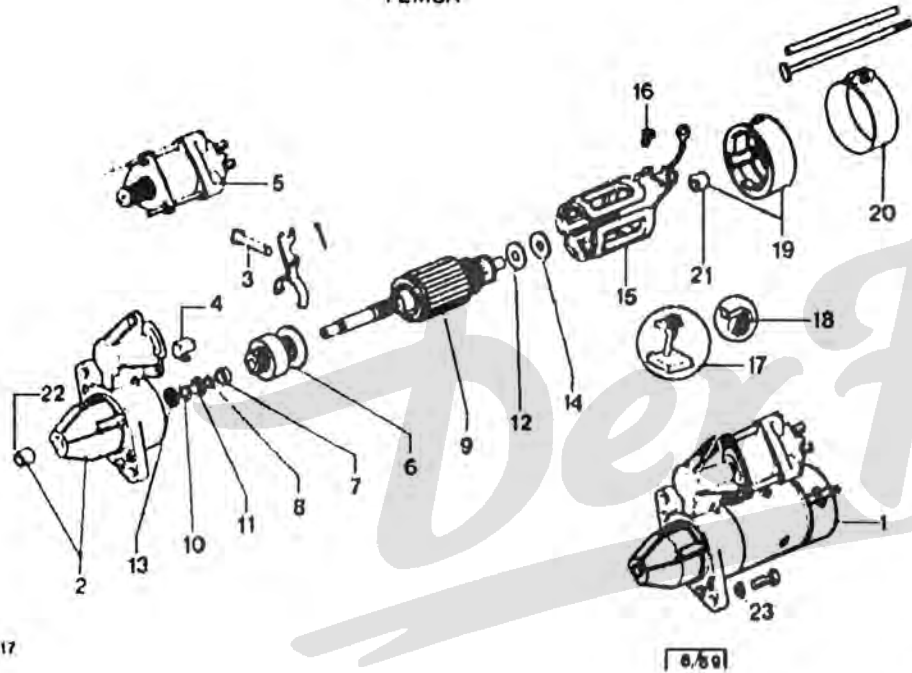

1117

0.50

02.5330.40

Z5330400

FEMSA MTA 12-30  
 ▶ 2641

14	5 444 748	01		RONDELLE SCHEIBE ARMATURE WASHER ARANDELA RONDELLA
15	95 580 166	01	ENS	DEMARREUR EST AT-ANLASSER STRT-MOTOR EXCH MOT ARRANO. EST MOT.AVV.REVISI.

16	5 444 751	04		VIS DE MASSE P-SCHUHSCHRAUBE POLE SHOE SCREW TORNILLO MASA VITE MASSA POL
17	5 444 752	01		BALAI DEMARREUR ANLASSERKOHLE START-MOT BRUSH ESCOBILLA SPAZZOLA AVVIAM
18	5 444 753	02		RESSORT FEDER BRUSH SPRING MUELLE MOLLA
19	5 444 754	01		PALIER AR LAGERDECKEL H. REAR BEARING TAPA TRASERA SUPPORTO POSTER
20	5 444 757	01		COLLIER METAL METALLSCHELLE METALLIC CLAMP ABRAZADERA COLLARE METALL
21	5 444 758	01		BAGUE CENTRAGE ZENTRIERING CENTRING RING CASQUILLO CENT. BOCCOLA CENTRAG
22	5 444 759	01		
23	79 03 058 011	02	DIAM 7,2X14,2-1,4	RONDELLE CONIQU KONUSSCHEIBE SPRING WASHER ARANDELA RONDELLA CONICA

15/02/91  
1117 02-5330-45  
PAGE : 1  
E08 ↑

**DEMARREUR**  
ANLASSER  
STARTER  
MOTOR DE ARRANQUE  
MOTORINO AVVIAMENTO

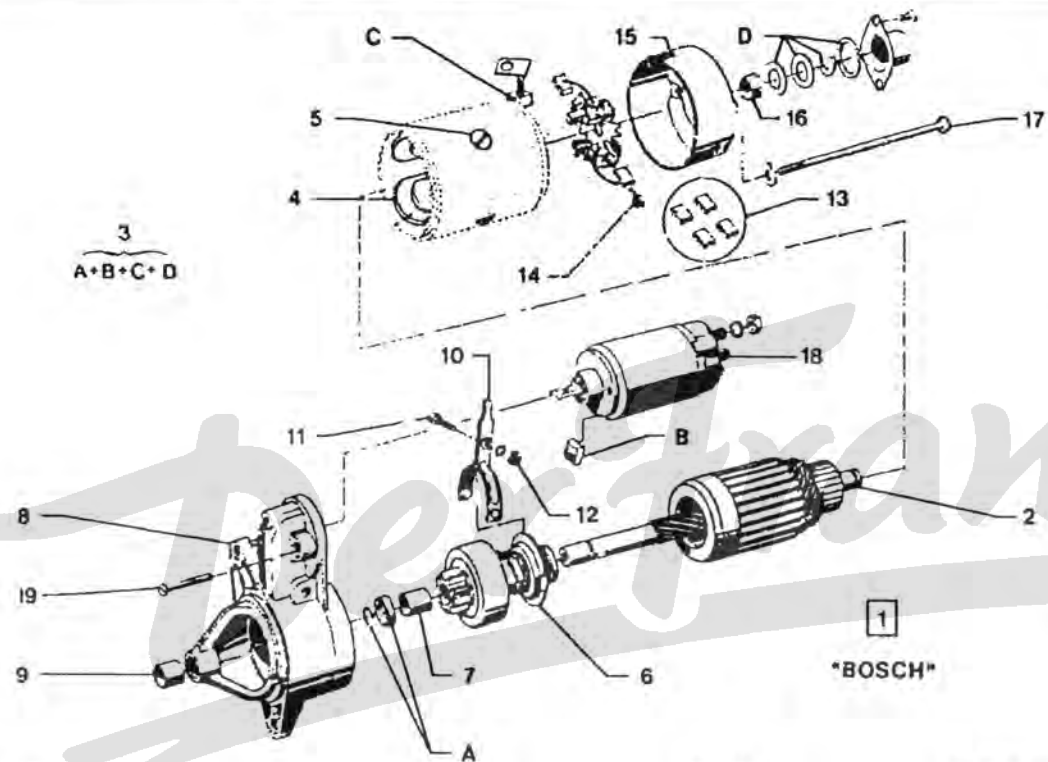

1117

08/89

02.5330.45

Z5330450

**BOSCH 9000141104**  
2642 ▶

- NOTA: LES PIECES NON REPEREES SONT NFP

01	5 473 630	01	DEMARREUR NEUF ANLASSER NEU STRT-MOTOR NEW MOT ARRANQ. NE MOTOR.AV.VUOVO
02	95 609 154	01	INDUIT ANKER STRTR MOT ARMAT INDUCIDO INDOTTO

03	95 609 170	01	ENS	JEU DE PIECES TEILESATZ SOLEN PART KIT JUEGO DE PIEZAS SERIE PEZZI
04	95 609 152	01		INDUCTEURS ERREGERWICKLUNG FIELD COIL BOBINAS INDUCTO INDICATORE
05	95 609 153	04		VIS DE MASSE P-SCHUHSCHRAUBE POLE SHOE SCREW TORNILLO MASA VITE MASSA POL
06	95 609 155	01		LANCEUR MAGNETSCHALTER STRTR-MOT DRIVE FINON ARRASTRE PIGNONE MOT.AW
07	95 589 944	02		COUSSINET LAGERBUCHSE SOLENOID BEARG COJINETE CUSCINETTO
08	95 609 156	01		PALIER LAGER BEARING CASQUILLO CUSCINETTO
09	95 609 157	01	AV	BAGUE CENTRAGE ZENTRIERRING CENTRING RING CASQUILLO CENT. BOCCOLA CENTRAG
10	95 609 169	01		FOURCHETTE GABEL START-MOT FORK HORQUILLA FORCELLA
11	95 609 158	01		AXE DE FOURCHE. GABELACHSE FORK PIN EJE HORQUILLA PERNO FORCELLA

.../...

15/02/91  
 1117 02-5330-45  
 PAGE : 2  
 E09 ↑

**DEMARREUR**  
 ANLASSER  
 STARTER  
 MOTOR DE ARRANQUE  
 MOTORINO AVVIAMENTO

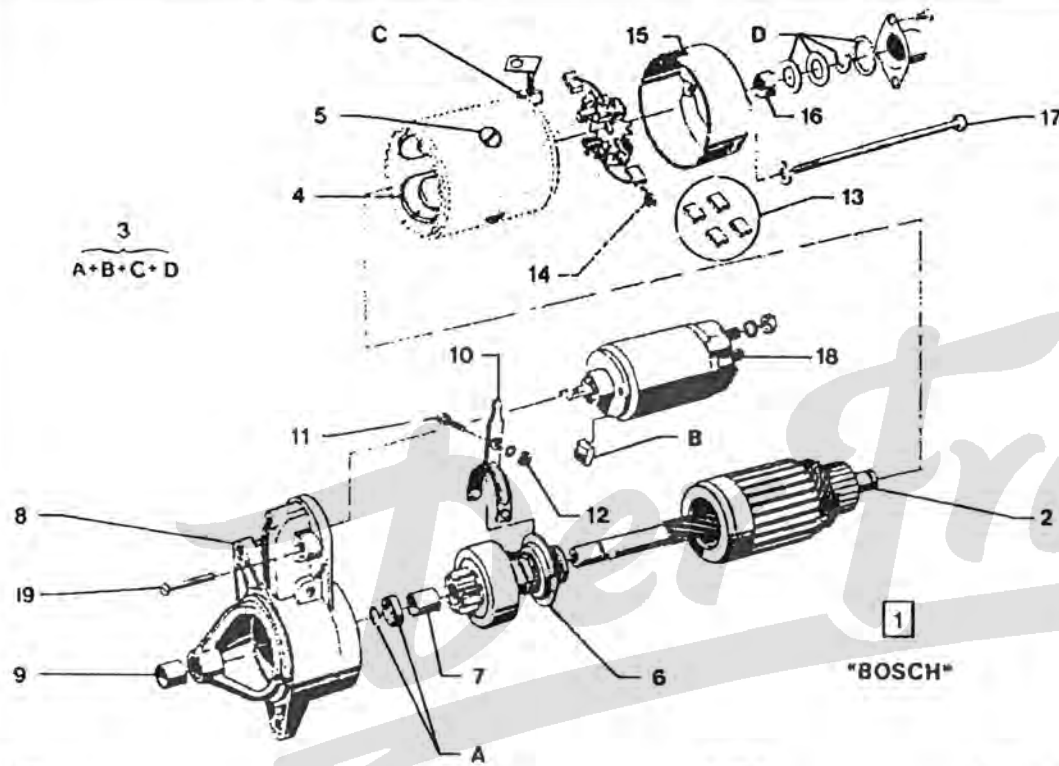

1117

06/89

02.5330.45

Z5330450

**BOSCH 9000141104**  
 2642 ▶

12	95 609 159	01	ECROU MUTTER NUT TUERCA DADO
13	95 609 168	01	BALAI DEMARREUR ANLASSERKOHLE START-MOT BRUSH ESCOBILLA SPAZZOLA AVVIAM

14	95 609 164	04	RESSORT FEDER BRUSH SPRING MUELLE MOLLA
15	95 609 161	01	PALIER LAGER BEARING CASQUILLO CUSCINETTO
16	95 572 917	01 RMP 95609162	COUSSINET LAGERBUCHSE COVER BEARING COJINETE CUSCINETTO
17	95 609 166	02	TIRANT STREBE STRUT TIRANTE TIRANTE
18	95 609 167	01	CONTACTEUR STECKVERBINDER CONTACT SWITCH CONTACTOR CONTATTORE
19	95 609 160	02	VIS SCHRAUBE STR-MTR SCREW TORNILLO VITE FISSAGGIO

NUMERO	SOUS-GROUPE	REP	NUMERO	SOUS-GROUPE	REP	NUMERO	SOUS-GROUPE	REP	NUMERO	SOUS-GROUPE	REP
5 418 536	02-2120-10	07	5 473 630	02-5330-10	01	25 223 019	02-1419-10	03	75 530 281		04
5 420 120	02-1419-20	10		02-5330-20	01	25 243 019	02-5324-10	11	75 530 717	02-1710-10	16
5 420 540		07		02-5330-40	01	26 161 509	02-1411-20	05	75 530 718		17
5 422 859	02-2112-10	03		02-5330-30	01		02-1411-10	05	91 536 302	02-5324-10	02
5 427 006	02-2120-10	03		02-5330-45	01	26 161 619		05	95 471 709	02-5320-30	03
5 427 438	02-2112-20	12	5 474 733	02-2112-20	02	26 201 039	02-5320-40	06	95 480 020		08
	02-2112-10	11	5 474 734		03		02-3121-10	14	95 493 444	02-2120-10	53
5 430 262	02-5330-10	06	5 474 735		08	26 203 169	02-5320-40	07	95 494 929	02-3124-10	03
5 433 737	02-2120-10	07	5 474 736		09	26 210 269	02-3121-10	17	95 495 646	02-2120-10	53
5 437 082	02-1434-10	03	5 474 737		10	75 420 119	02-1419-10	10	95 533 290	02-1434-20	02
	02-1434-15	03	5 474 738		06	75 420 121		09	95 534 707	02-5324-10	05
5 444 736	02-5330-40	02	5 474 739		11		02-1419-20	09	95 535 483	02-5320-10	03
5 444 738		03	5 474 740		07	75 420 125		11	95 536 340	02-2120-10	04
5 444 739		04	5 474 741		05	75 420 126	02-1710-10	08	95 539 008		01
5 444 740		05	5 474 742		01	75 420 178	02-3121-10	12	95 545 941	02-1434-10	01
5 444 741		06	5 478 724	02-1434-20	03		02-3120-10	08		02-1434-15	01
5 444 742		07	5 485 839	02-5320-20	10		02-3124-10	08	95 546 010	02-5330-30	16
5 444 743		08	5 486 485	02-1434-15	02	75 489 718	02-1434-20	05	95 546 429	02-1710-10	02
5 444 744		09		02-1434-10	02	75 490 505	02-1411-10	04	95 546 597		01
5 444 745		11	5 486 547	02-5330-10	08	75 491 225		02	95 559 036	02-3120-10	11
5 444 746		13	5 486 799		10		02-1411-20	02	95 568 478	02-1434-15	04
5 444 747		12	5 489 274	02-2112-10	13	75 491 352		03		02-1434-10	04
5 444 748		14	5 490 486	02-1411-20	04		02-1411-10	03	95 569 088	02-2120-10	05
5 444 751		16	5 501 011	02-5324-10	01	75 491 948	02-2120-10	64	95 572 917	02-5330-45	16
5 444 752		17	5 501 070	02-1434-20	01	75 492 217	02-3120-10	02	95 576 962	02-1419-10	05
5 444 753		18	5 501 074	02-1434-15	01		02-3121-10	06	95 577 882	02-1434-10	02
5 444 754		19	5 501 075	02-1434-10	07	75 510 566	02-2120-10	02		02-1434-15	02
5 444 757		20		02-1434-15	06	75 512 011	02-5320-40	05	95 577 884	02-1438-10	02
5 444 758		21	5 503 400	02-1710-10	05	75 512 012		04	95 580 166	02-5330-40	15
5 444 759		22	5 504 891	02-1434-20	04	75 512 014		02		02-5330-30	08
5 446 242	02-5320-20	02	5 505 808	02-2120-10	62	75 512 015		03	95 581 013	02-1411-10	01
5 446 244		05	5 505 809		61	75 512 846	02-5330-10	14	95 581 245	02-2120-10	04
5 446 245		04	5 507 094	02-1419-10	11	75 514 352	02-1419-10	54	95 582 995	02-1434-10	05
5 450 095	02-5330-40	10	5 507 099		01	75 514 904	02-1419-20	08	95 588 211	02-5330-25	03
5 451 034	02-1438-10	01	5 507 100		04	75 515 254	02-1710-10	03	95 589 944	02-5330-45	07
5 451 055	02-1438-20	01	5 507 119	02-5330-30	15	75 515 401		06	95 595 730	02-1434-10	06
5 456 443	02-1411-20	01	5 507 120		14	75 515 541	02-1419-10	02		02-1434-15	05
5 469 196	02-5330-10	11	5 507 124		10	75 515 609	02-1438-10	32	95 609 152	02-5330-45	04
5 469 497		07	5 507 125		11	75 515 610		03	95 609 153		05
5 469 499		02	5 507 126		12	75 517 320	02-1438-20	02	95 609 154		02
5 469 500		14	5 507 127		04	75 517 322		03	95 609 155		06
5 469 533		09	5 507 130		02	75 521 653	02-1710-10	09	95 609 156		08
5 469 534		13	5 507 132		09	75 523 566		10	95 609 157		09
5 471 236	02-5320-30	02	5 508 266	02-1710-10	02	75 526 180	02-5324-10	04	95 609 158		11
5 471 237		05	5 508 267		01	75 526 182		03	95 609 159		12
5 471 238		04	5 508 324	02-2120-10	63	75 526 989	02-5330-25	06	95 609 160		19
5 471 241		07	5 509 540	02-1419-10	09	75 527 611	02-3121-10	16	95 609 161		15
5 473 145	02-5320-40	01	22 559 029	02-1710-10	11		02-3120-10	06	95 609 164		14
	02-5320-30	01	22 769 009		13		02-3124-10	06	95 609 166		17
	02-5320-20	01	23 464 319	02-5324-10	07	75 529 967	02-1710-10	04	95 609 167		18
	02-5320-10	01	23 871 019		06	75 530 276	02-5330-20	02	95 609 168		13

B05 ↑

INDEX

Catalogue 1117

NUMERO	SOUS-GROUPE	REP	NUMERO	SOUS-GROUPE	REP	NUMERO	SOUS-GROUPE	REP
95 609 169		10	AM 314 9		05	79 03 032 003	02-2120-10	10
95 609 170		03		02-3121-10	09	79 03 032 036	02-5324-10	12
95 616 712	02-3120-10	03		02-3120-10	05	79 03 032 124	02-1411-10	08
	02-3121-10	07	AM 533 031 A	02-5330-10	07		02-1411-20	08
95 618 180	02-5330-20	09	AM 533 248 A		04	79 03 032 249		07
95 618 183	02-5330-25	09	AY 142 90	02-1419-20	05		02-1411-10	09
95 618 193	02-5330-20	08	AY 532 013	02-5320-10	05	79 03 032 252	02-1710-10	15
95 618 194	02-5330-25	08	AY 532 11		04	79 03 056 003	02-2112-10	12
95 618 200		05	AY 532 17	02-5324-10	02	79 03 056 012	02-1411-10	07
95 618 201	02-5330-20	05	AY 532 62	02-5320-10	06	79 03 056 125	02-5324-10	09
95 618 206		07	AY 532 62 A	02-5320-20	08	79 03 058 011		10
95 618 207	02-5330-25	07	AY 8312 000	02-3120-10	01		02-5330-10	15
95 618 271	02-5330-10	03		02-3121-10	01		02-5330-40	23
95 618 377	02-2120-10	07	AY 9532 912 L	02-5320-20	11		02-5330-30	18
95 618 773	02-5330-25	01	AY 9532 995 A		03	79 03 066 995	02-1419-10	06
95 619 038	02-2120-10	07		02-5320-10	02	79 03 066 999		08
95 619 468	02-5330-25	02	AY 9532 995 B	02-5320-20	06	79 03 101 789	02-3124-10	10
95 619 469		04	AYB 212 7	02-2120-10	07	79 03 201 020	02-3120-10	10
95 619 609	02-5330-10	12	AZ 142 107	02-1419-20	03		02-3121-10	16
95 623 773	02-1411-20	06	AZ 142 301 A		01	79 03 201 132	02-1710-10	07
	02-1411-10	06	AZ 142 387 A		05	94 05 724 138	02-5320-30	06
95 624 272	02-2120-10	09	AZ 142 95		02	94 05 816 118	02-5330-20	10
95 624 273	02-1710-10	14	AZ 211 05	02-2112-10	01		02-5330-25	10
95 633 279	02-3121-10	11	AZ 211 116		03			
	02-3120-10	07	AZ 211 17		05			
	02-3124-10	07	AZ 211 8		04			
95 635 352		01	AZ 211 9		07			
95 646 200	02-5320-40	06	AZ 212 140	02-2120-10	06			
95 646 201		07	AZ 212 140 A		06			
95 646 202		04	AZ 312 87	02-3121-10	04			
95 646 215	02-5330-30	17	AZ 332 5		05			
95 646 216		07	AZ 332 99		13			
95 646 217		03	AZ 332 99 A		13			
95 646 218		13	AZ 332 99 B		13			
95 650 913	02-3124-10	11	AZ 332 99 C		13			
96 034 551		52	AZ 332 99 D		13			
		02	AZ 332 99 E		13			
A 142 83	02-1419-20	04	DV 533 012	02-5330-20	06			
AK 171 99	02-1710-10	12	DV 9533 267 A	02-5330-10	05			
AK 533 143 A	02-5330-30	05	DX 533 131 A	02-5330-20	11			
AK 533 144 A		06	GX 11 154 01A	02-5320-20	09			
AM 142 67	02-1419-10	07	GX 11 160 01A		07			
AM 211 204 A	02-2112-10	02	77 01 022 169	02-5330-20	03			
AM 211 92 B		06	79 03 001 708	02-5324-10	08			
	02-2112-20	04		02-2112-20	13			
AM 212 207 A	02-2120-10	07		02-2112-10	09			
AM 312 01 A	02-3121-10	02	79 03 007 065	02-2120-10	08			
AM 312 7 D		03	79 03 007 094	02-3124-10	09			
AM 314 4 C	02-3120-10	04		02-3121-10	15			
	02-3121-10	08		02-3120-10	09			
	02-3124-10	04	79 03 007 147	02-2112-10	10			

15/02/91 1117 <b>TABLEAU DES VUES</b> AUFSTELLUNG DER BILDER TABLE OF PICTURE B01 ↑ TABLA DE VISTAS TABELLA DELLE VEDUTE		<b>GROUPE</b> GROUP GROUP <b>03</b> GRUPO GRUPPO		<b>AMORTISSEURS AVANT ET ARRIERE</b> STOSSDAEMPFER · ANSCHLAEGE SHOCK ABSORBER · STOPS AMORTIGUADORES · TOPES AMORTIZZATORI REGGISPINTA	4360-10	C15 D15
<b>SOUS-GROUPE</b> UNTERGRUPPE SUBGROUP SUBGRUPO SOTTOGRUPPO	<b>NUMERO</b> NUMMER NUMBER NUMERO NUMERO	<b>VUE</b> BILD PICTURE VISTA VEDUTA	<b>DIRECTION - VOLANT</b> LENKRAD STEERING WHEEL DIRECCION - VOLANTE STERZO - VOLANTE	4410-10	D14 D13	
<b>ESSIEU AVANT</b> VORDERE ACHSE FRONT AXLE EJE DELANTERO ASSALE ANTERIORE	4120-10	C02 C03 C04	<b>ANTIVOL</b> DIEBSTAHLSICHERUNG ANTI-THEFT DEVICE ANTIRROBO ANTIFURTO	4415-10	D12 D11	
<b>PIVOTS</b> ACHSKOERPER PIVOTS PIVOTES PIVOTS	4130-10	C05 C06	<b>DIRECTION - BARRES</b> SPURSTANGEN STEERING RODS DIRECCION BARRAS STERZO BARRE	4419-10	D10 D09	
<b>MOYEUX AVANT - JANTES</b> VORDERRADNABEN · RADFELGEN FRONT HUBS · WHEELS NUCLEOS DELANTEROS · RUEDAS MOZZI ANTERIORE · RUOTE	4160-10	C07 C08	<b>DIRECTION - PIGNON - GLISSIERE</b> LENKUNG · RITZEL · FUEHRUNG STEERING · PINION AND SLIDE DIRECCION · PINON · DESLIZADERA STERZO · PIGNONE · SLOTA	4423-10	D08 D07	
<b>ESSIEU ARRIERE</b> HINTERE ACHSE REAR AXLE EJE TRASERO ASSALE POSTERIORE	4229-10	C09 C10	<b>DIRECTION CREMAILLERE</b> LENKUNGSZAHNSYANGE STEERING RACK DIRECCION CREMALLERA STERZO · CREMAGLIERA	4424-10	D06 D05	
<b>MOYEU ARRIERE</b> HINTERE NABEN REAR HUBS CUBOS TRASEROS MOZZI POSTERIORI	4260-10	C11 C12				
<b>POTS DE SUSPENSION</b> FEDERUNGSTOEPFE SUSPENSION UNITS TUBOS DE SUSPENSION CILINDRI DI SOSPENSIONE	4341-10	C13 C14				

15/02/91  
 1117 03-4120-10  
 PAGE : 1  
 C02 ↑

**ESSIEU AVANT**  
 VORDERE ACHSE  
 FRONT AXLE  
 EJE DELANTERO  
 ASSALE ANTERIORE

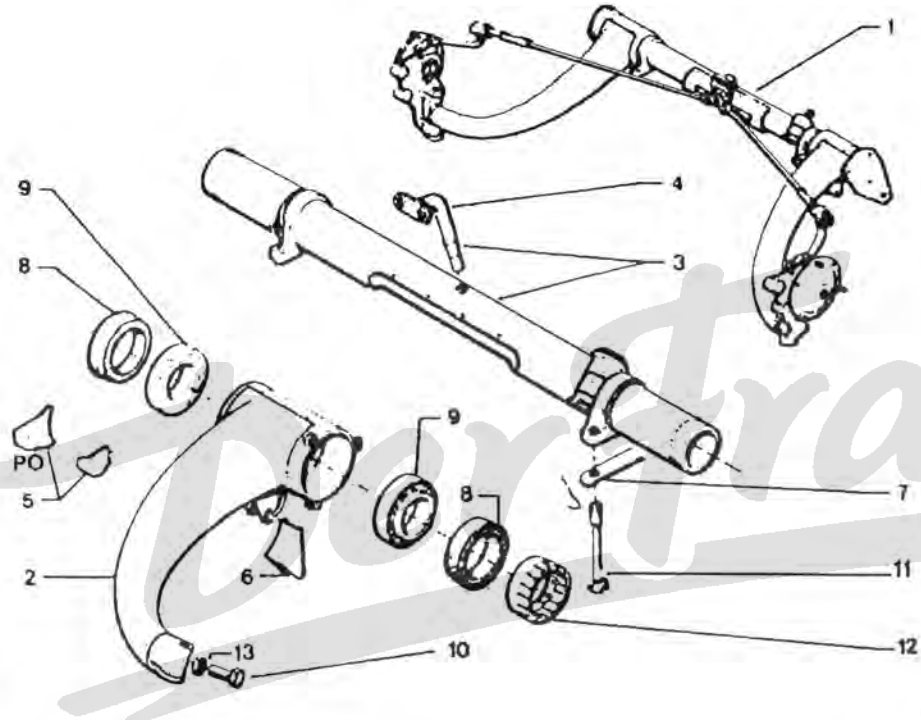

1114

3.412.10  
 Z4120100

03	5 471 866	01		TRAVERSE TRAVERSE STRG CPOSSMEM'3R TRAVIESA TRAVERSA
04	5 428 292	01	AR 2 DIAM 7X1.00	SUPPORT MOTEUR MOTORHALTER ENGINE MOUNTING SOPORTE MOTOR SUPPORTO MOTORE
05	A 412 93	01	D-	BUTEE D'APPUI ANSCHLAGSTUECK REST STOP TOPE DE APOYO REGGISPINTA
	A 412 93 A	01	G-	-
06	A 437 89	02	29X44	
07	A 414 89	02	2 DIAM 10-ENT 102	ARRETOIR ARRETIERUNG RETAINER RETIEN ARRESTO
08	95 568 931	04	DIAM 71,5X96X7	BAGUE DE PALIER LAGERBUCHSE BEARING BUSH CASQUILLO EJE BOCCOLA SUPP.
09	26 207 519	04	63,5X95X17	ROULEMENT LAGER ARM BEARING RODAMIENTO CUSCINETTO
10	23 826 319	04	9X1,25-28	VIS TH SCHRAUBE CAPSCREW TORNILLO TH VITE
11	AZ 414 90	04	TH 10X1,50-1,25	-
12	AM 414 91	02	DIAM 63X1,50	ECROU CRENELE KRONENMUTTER CASTLE NUT TUERCA ALMENADA DADO A SPINA
01	5 504 969	01	COMPLET	ESSIEU AV VORDERE ACHSE FRONT AXLE EJE DELANTERO ASSALE ANT.
02	5 504 937	01	G-	BRAS AV VORD.ARM FRONT ARM BRAZO AV BRACCIO ANTERIO
	5 504 938	01	D-	-

.../...

**ESSIEU AVANT**  
**VORDERE ACHSE**  
**FRONT AXLE**  
**EJE DELANTERO**  
**ASSALE ANTERIORE**

**XT**

51	5 504 970	01	COMPLET -RTT -ATMOSPHERE POUSSIERES -PISTE	ESSIEU AV VORDERE ACHSE FRONT AXLE EJE DELANTERO ASSALE ANT.
	5 504 971	01	COMPLET -CAD	-
52	5 504 939	01	G- -ARMEE -RTT -ATMOSPHERE POUSSIERES -CAD -PISTE	BRAS AV VORD.ARM FRONT ARM BRAZO AV BRACCIO ANTERIO
	5 504 940	01	D- -ARMEE -RTT -ATMOSPHERE POUSSIERES -CAD -PISTE	BRAS TRIANGLE ARM TRIANGLE ARM BRAZO BRACCIO
	5 504 947	01	G- -ATMOSPHERE POUSSIERES -CAD	BRAS AV VORD.ARM FRONT ARM BRAZO AV BRACCIO ANTERIO
	5 504 948	01	D- -ATMOSPHERE POUSSIERES -CAD	-
53	5 471 870	01	-ARMEE -RTT -PISTE	TRAVERSE TRAVERSE STRG CROSSMEMBR TRAVIESA TRAVERSA
	5 471 968	01	-CAD	-
55	A 412 93 B	01	D- -ARMEE -RTT -ATMOSPHERE POUSSIERES -CAD -PISTE	BUTEE CAOUTCHOU ANSCHLAG RUBBER BUFFER TOPE GOMA REGGISPINTA
	A 412 93 C	01	G- -ARMEE -RTT -ATMOSPHERE POUSSIERES	-

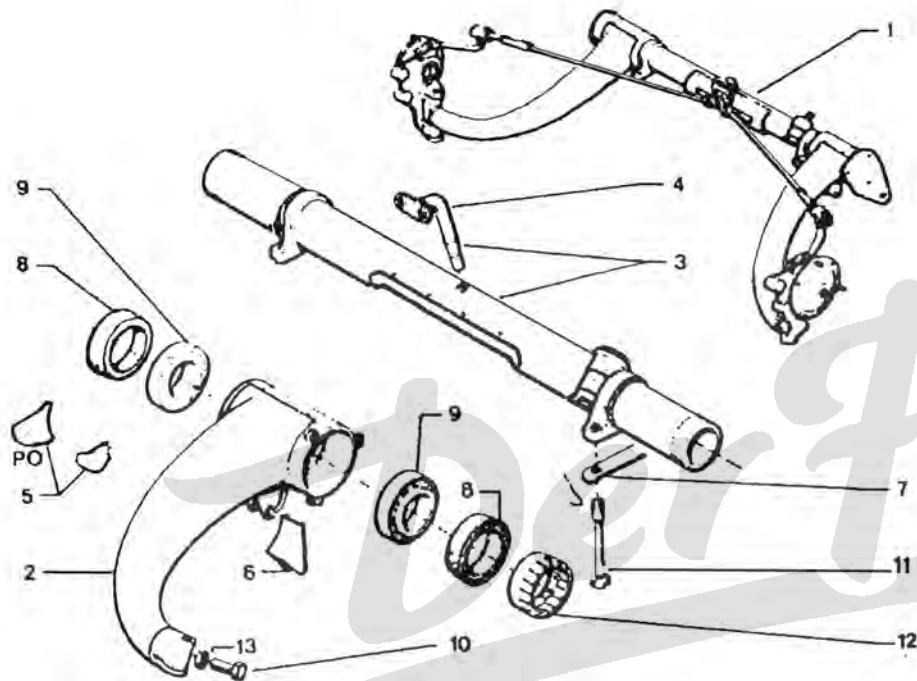

1114

3.412.10  
 Z4120100

13	25 223 019	04	HE9X1.25	ECROU MUTTER NUT TUERCA DADO
----	------------	----	----------	--



15/02/91  
1117 03-4120-10  
PAGE : 3  
C04 ↑

**ESSIEU AVANT**  
**VORDERE ACHSE**  
**FRONT AXLE**  
**EJE DELANTERO**  
**ASSALE ANTERIORE**

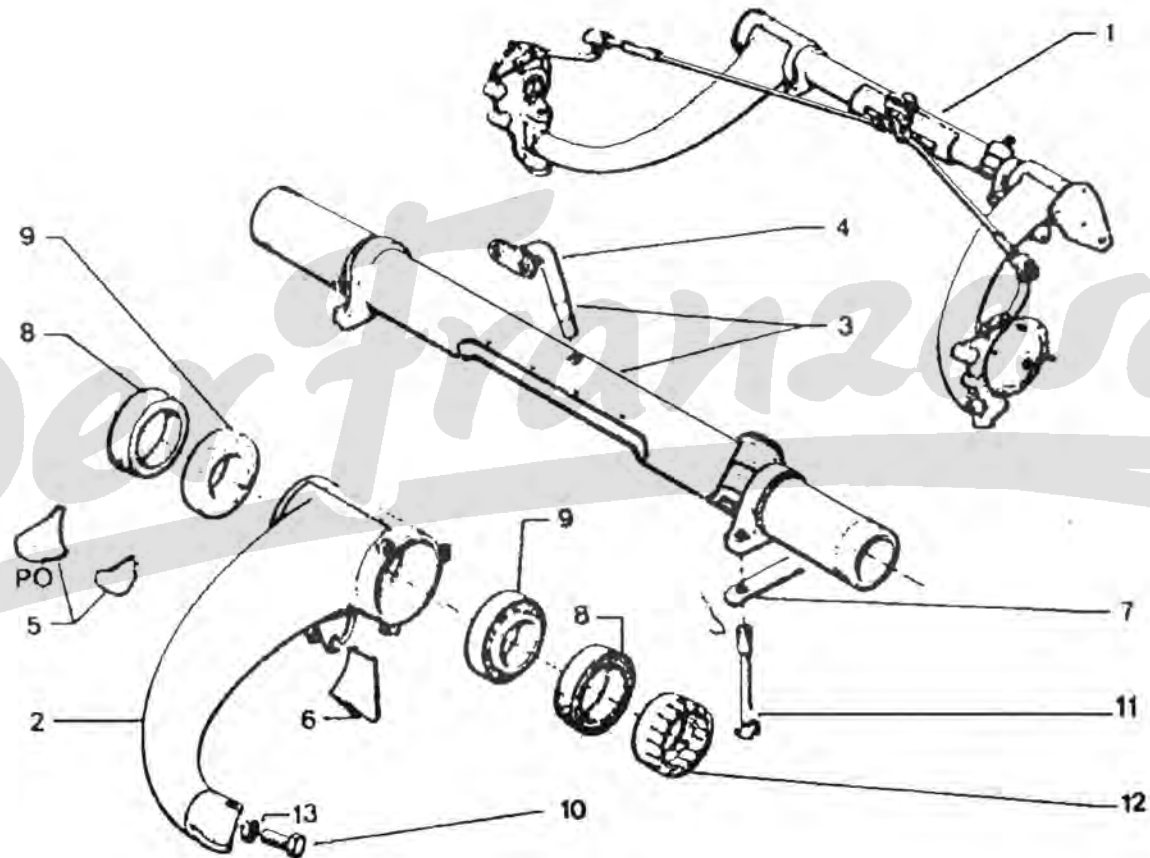

1114

3.412.10  
Z4120100

55 \* A 412 93 C

01 (suite)  
-CAD  
-PISTE

**BUTEE CAOUTCHOU**  
**ANSCHLAG**  
**RUBBER BUFFER**  
**TOPE GOMA**  
**REGGISPINTA**

15/02/91  
1117 03-4130-10  
PAGE : 1  
C05 ↑

**PIVOTS**  
ACHSKOERPER  
PIVOTS  
PIVOTES  
PIVOTS

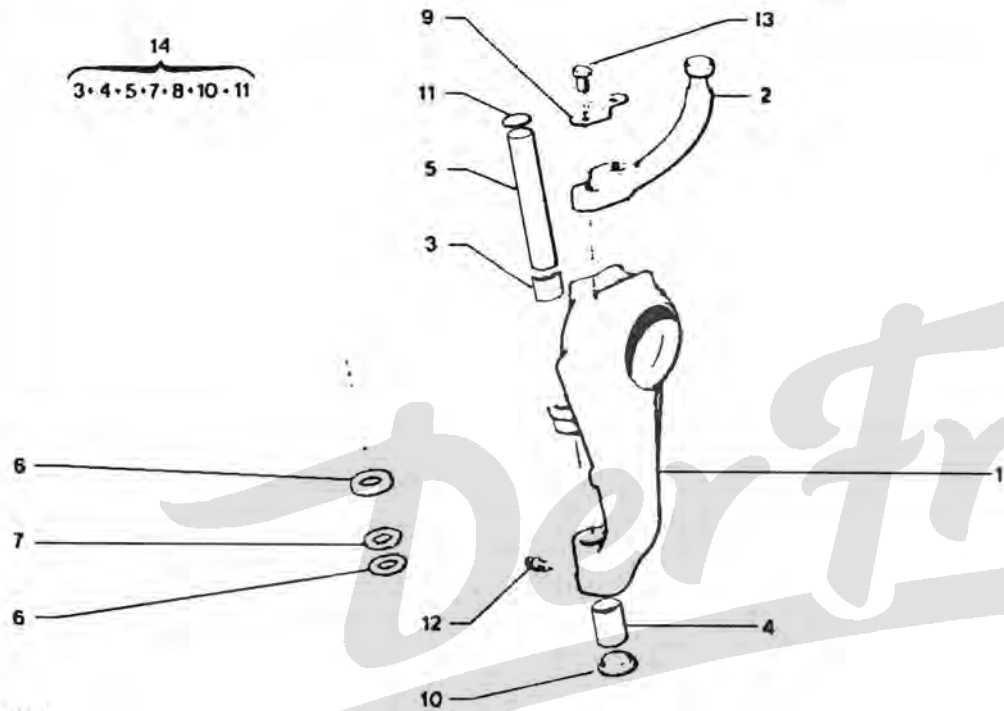

1114

3.413.10

Z4130100

01	5 502 003	02	DIAM 74X1,50	PIVOT FUSEE AV ACHSSCHENKELBOL FRT SWIVEL PIN MANGUETA AV PIVOT	03	A 413 2	02	21X19X17	BAGUE CENTRAGE ZENTRIERRING CENTRING BUSH CASQUILLO CENT BOCCOLA CENTRAG
02	95 569 500	01	G-	LEVIER DE CDE BET.-HEBEL CONTROL LEVER PALANCA MANDO LEVA COMANDO	04	A 413 3 B	02	21X17,06X31	-
	95 569 501	01	D-	-	05	A 413 5 A	02	17X110	AXE DE PIVOT ZAPFEN SWIVEL PIN EJE MANGUETA PERNO
					06	A 413 7	99	27X17,1 E 2,3	RONDELLE BUTEE EINSCHL SCHEIBE WASHER ARANDELA TOPE RONDELLA REGISP
						A 413 7 A	99	27X17,1 E 2,5	-
						A 413 7 B	99	27X17,1 E 2,7	-
					07	A 413 8	02	17,1X27 E 2 BRONZE	-
					08	A 413 9	02	17,1X31,5 E 6,5	RONDELLE SCHEIBE WASHER ARANDELA RONDELLA
					09	AM 413 89	02	2 DIAM 8 ENT 28	ARRETOIR ARRETIERUNG RETAINER RETEH ARRESTO
					10	A 413 90	02	22X1,00	BOUCHON STOPFEN PLUG TAPON TAPPO
					11	A 413 95	02	DIAM 24 E 3	BOUCHON EXPANS. STOPFEN EXPANDING PLUG TAPON CUBETA TAPPO
					12	24 737 019	02	7X1,00	GRAISSEUR SCHMIERNIPPEL OILER ENGRASADOR INGRASSATORE

.../...

15/02/91  
 1117 03-4130-10  
 PAGE : 2  
 C06 ↑

**PIVOTS**  
 ACHSKOERPER  
 PIVOTS  
 PIVOTES  
 PIVOTS

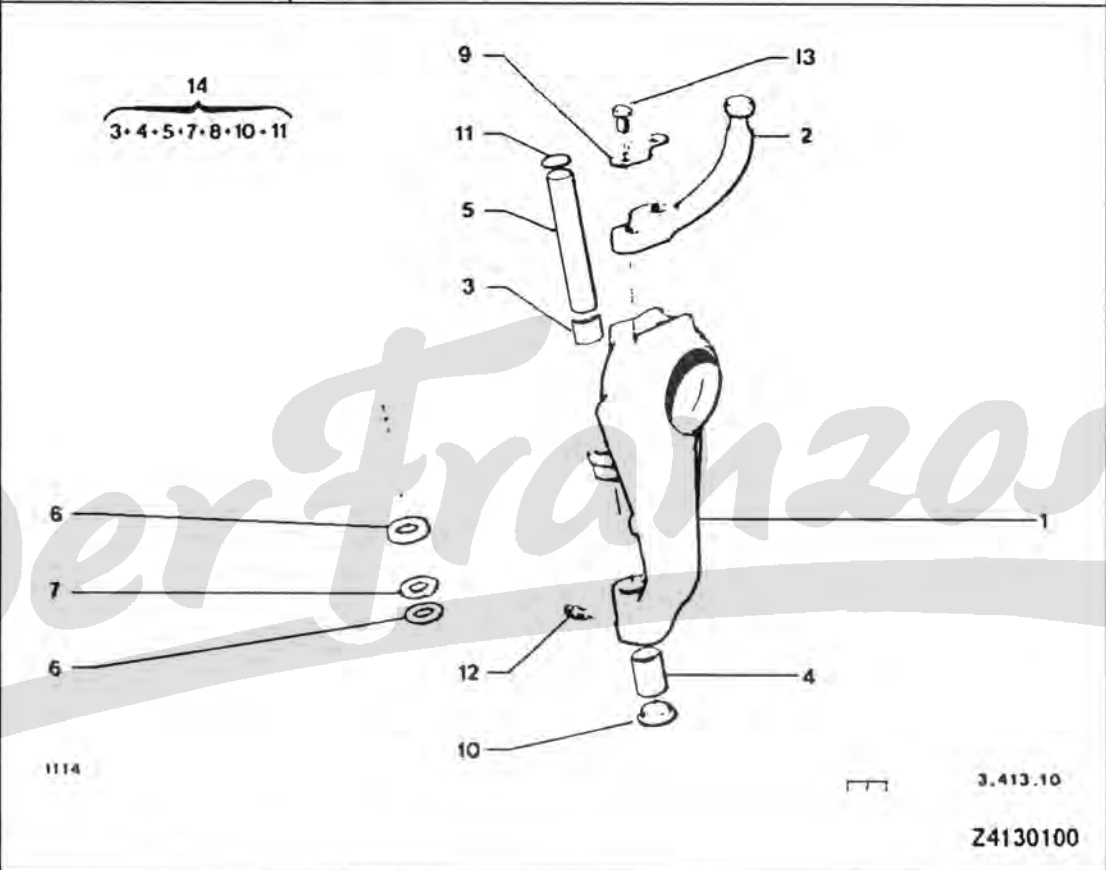

13	• 95 623 739	02	TH 7X100-28	VIS TH SCHRAUBE CAPSCREW TORNILLO TH VITE
	• 23 746 509	02	7X1,00-38	-
14	• 5 451 858	02	ENS	NEC REPARATION REPARATURSATZ REPAIR KIT JUEGO REPARACI NECESSARIO

**MOYEUX AVANT - JANTES**  
 VORDERRADNABEN - RADFELGEN  
 FRONT HUBS - WHEELS  
 NUCLEOS DELANTEROS - RUEDAS  
 MOZZI ANTERIORE - RUOTE

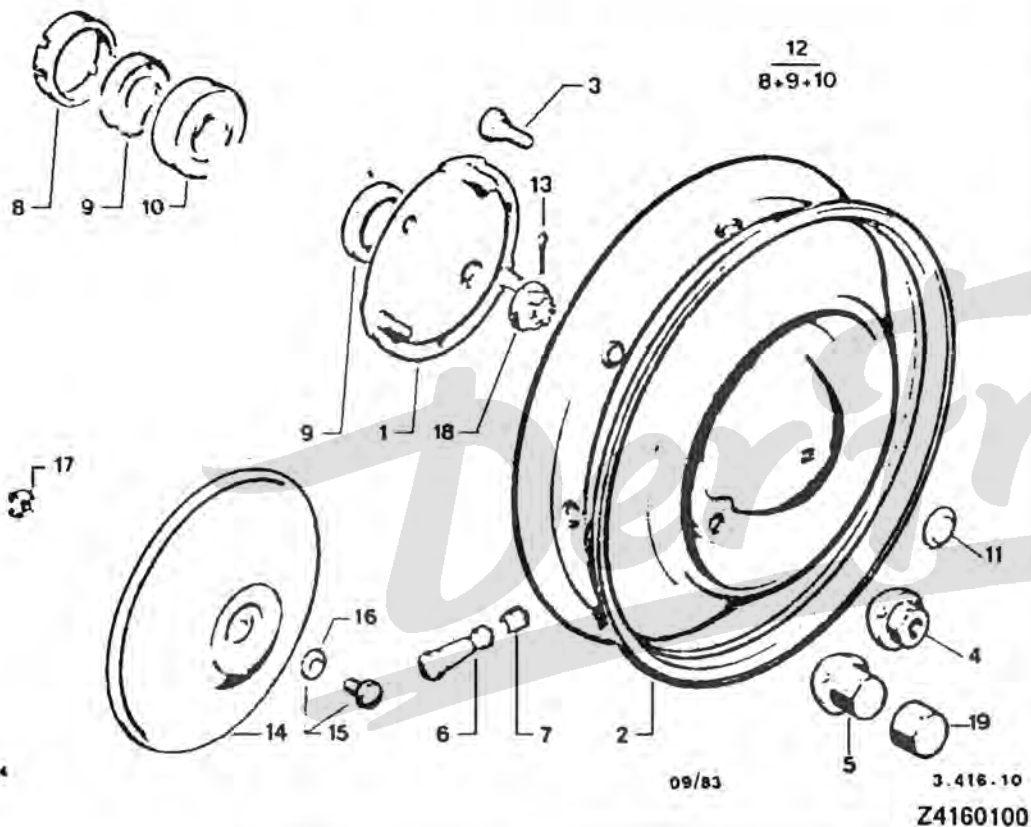

03	95 544 122	06	12X1.25-30 ▶ 1605	AXE DE FIX ROUE RADBEF BOLZEN WHEEL FIX SHAFT EJE FIX RUEDA PERNO FISS.RUOT
04	75 419 948	12	12X1.25	ECROU FIX ROUE RADMUTTER WHEEL MNTG NUT TUERCA DE RUEDA DADO DELLA RUOT
05	79 10 034 642	12	12X1.25 ▶ 2335	ECROU ROUE TOLE MUTTER STAHLFI STEEL WHEEL NUT TUERCA DE RUEDA DADO RUOTA LAM.
06	5 458 682	05		VALVE COMPLETE VENTIL KOMPLETT ASSEMBLY VALVE VALVULA COMPLET VALVOLA COMPLET
07	75 491 339	05		BOUCHON VALVE KAPPE VALVE PLUG TAPON VALVULA TAPPO
08	A 416 99	02	74 X 1,50 E 10 5	ECROU CRENELE KRONENMUTTER CASTLE NUT TUERCA ALMENADA DADO A SPINA
09	75 532 316	04	45X52X8	BAGUE ANPRESSRING BEARING RING CASQUILLO BOCCOLA
10	26 200 119	02	35X72X27	ROULEMENT LAGER WHL HUB BEARING RODAMIENTO CUSCINETTO
11	AZ 416 84	05		OBTURATEUR STOPFEN PLUG OBTURADOR OTTURATORE

1	AZ 416 01	02	22 CANNELURES	MOYEU DE ROUE RADNABE WHEEL HUB BUJE DE RUEDA MOZZO RUOTA
2	AM 416 4 A	05	BM 4 JX15 FH 3 30	ROUE TOLE STAHLFELGE STEEL WHEEL LLANTA CHAPA RUOTA LAMIERA

15/02/91  
 1117 03-4160-10  
 PAGE : 2  
 C08 ↑

**MOYEUR AVANT - JANTES**  
 VORDERRADNABEN - RADFELGEN  
 FRONT HUBS - WHEELS  
 NUCLEOS DELANTEROS - RUEDAS  
 MOZZI ANTERIORE - RUOTE

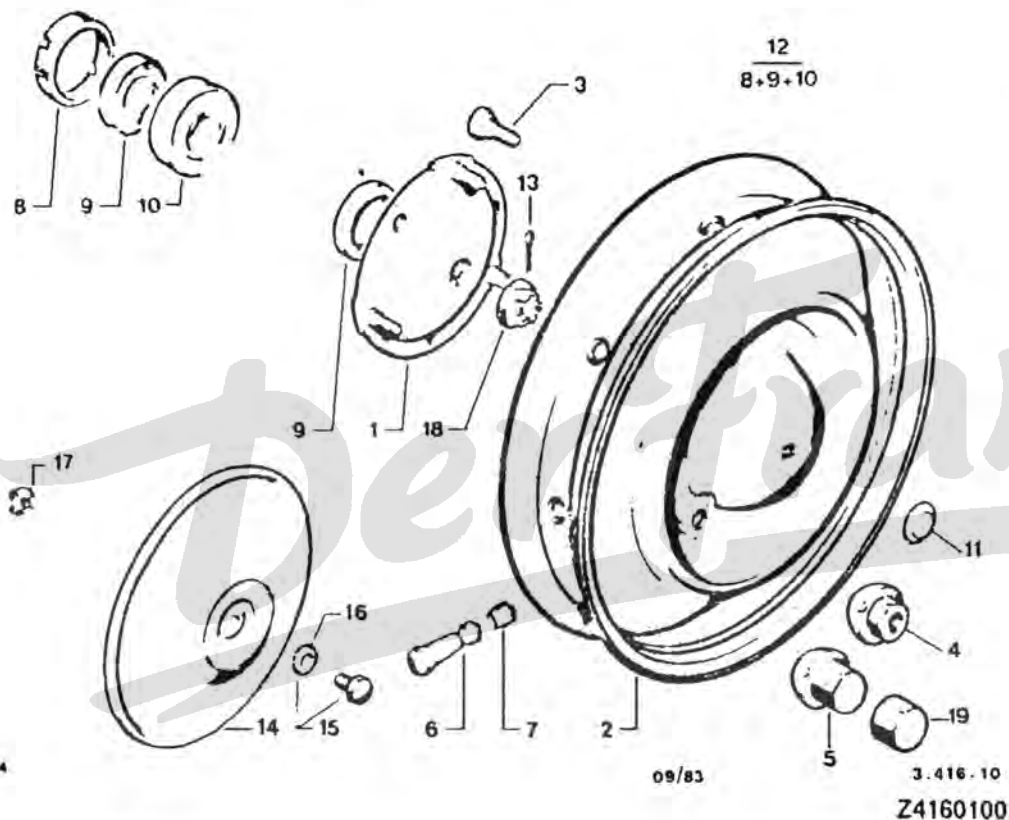

14	AY 854 1	04	DIAM 216.5 -CHARLESTON	ENJOLIVEUR ROUE RADZIERKAPPE WHEEL MOULDING EMBELLECEDOR CALOTTA RUOTA
15	5 474 954	01	-CHARLESTON	ENS FIX ENJOLI. BEFEST.-SATZ HUBCAP FIX ASSY CONJ.FIJACION CALOTTA RUOTA
16	75 416 826	04	-CHARLESTON	RONDELLE PLATE FLACHSCHEIBE PLAIN WASHER ARANDELA PLANA RONDELLA PIATTA
17	ZC 9615 865 U	05	10X1.50 -CHARLESTON	ECROU EN CAGE KAEFIGMUTTER CAGED NUT TUERCA EN CAJA DADO IN GABBIA
18	5 420 543	02	22X1,50 H 19.25	ECROU CRENELE KRONENMUTTER CASTLE NUT TUERCA ALMENADA DADO A SPINA
19	79 10 031 881	12	▶ 2335	CAPUCHON KAPPE SCREW CAP CAPUCHON CUFFIA

12	5 451 859	02	ENS	ENS ROULEMENT LAGERSATZ HUB BEARING CONJ.RODAMIENTO INS.CUSCINETTO
13	22 600 019	02	DIAM 5-25	GOUPILLE STIFT PIN PASADOR COPPIGLIA

15/02/91  
1117 03-4229-10  
PAGE : 1  
C09 ↑

**ESSIEU ARRIERE**  
HINTERE ACHSE  
REAR AXLE  
EJE TRASERO  
ASSALE POSTERIORE

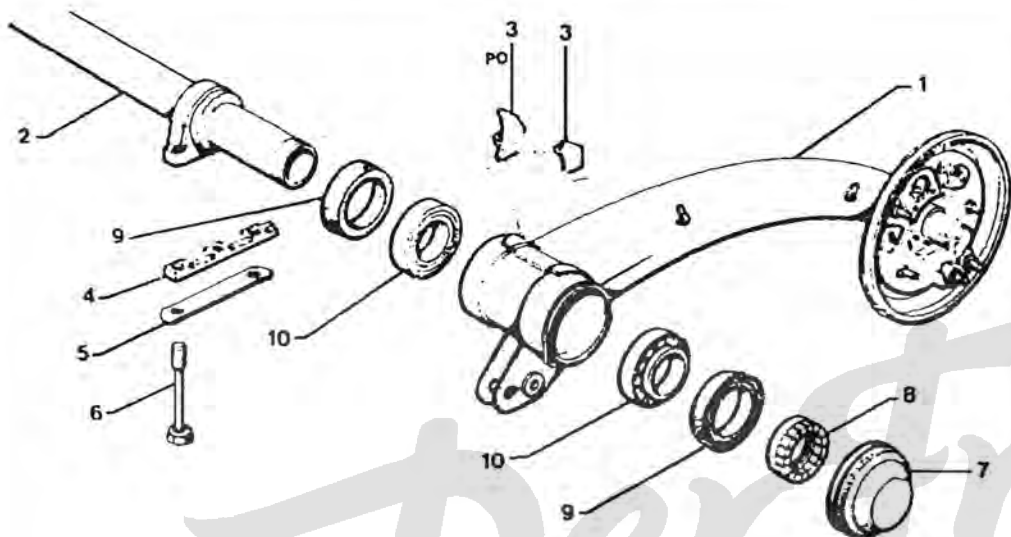

1117

[6/89]

03.4229.10

Z4229100

01	•	5 443 708	01	G-	BRAS SUSPENSION SCHWINGARM SUSPENSION ARM BRAZO BRACCIO
	•	5 443 709	01	D-	-
02	•	AM 424 01 B	C1	2 DIAM 21	TRAVERSE AR TRAVERSE SUSP CROSSMEMBR TRAVIESA TRAVERSA

03	•	A 412 93 A	01	G-	BUTEE D'APPUI ANSCHLAGSTUECK REST STOP TOPE DE APOYO REGGISPINTA
	•	A 412 93	01	D-	-
04	•	AU 424 97 A	02	120X20 E 10	CALE TRAVERS.AR UNTERLACE CROSSMEMBR SHIM CALA TRAVIESA SPESSORE
05	•	A 414 89	02	2 DIAM 10-ENT 102	ARRETOIR ARRETIERUNG RETAINER RETEN ARRESTO
06	•	AZ 424 96	04	TH 10X1,50-135	VIS SCHRAUBE CROSSMEMB SCREW TORNILLO VITE TRAVERSA
07	•	AM 422 50 A	02	1 DIAM 3,5	BOUCHON STOPFEN CROSSMEMBR PLUG OBTURADOR TAPPO
08	•	AM 414 91	02	DIAM 63X1,50	ECROU CRENELE KRONENMUTTER CASTLE NUT TUERCA ALMENADA DADO A SPINA
09	•	95 568 931	04	DIAM 71,5X96X7	BAGUE DE PALIER LAGERBUCHSE BEARING BUSH CASQUILLO EJE BOCCOLA SUPP.
10	•	26 207 519	04	63,5X95X17	ROULEMENT LAGER ARM BEARING RODAMIENTO CUSCINETTO

.../...

15/02/91  
 1117 03-4229-10  
 PAGE : 2  
 C10 ↑

**ESSIEU ARRIERE**  
 HINTERE ACHSE  
 REAR AXLE  
 EJE TRASERO  
 ASSALE POSTERIORE

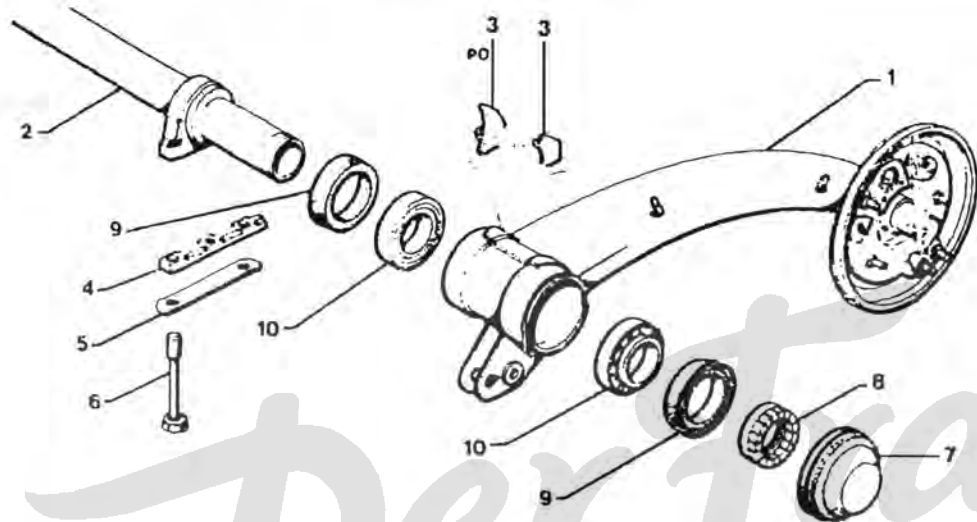

1117

[6/89]

03.4229.10

Z4229100

51	5 443 731	01	-PISTE	BRAS SUSPENSION SCHWINGARM SUSPENSION ARM BRAZO BRACCIO
53	A 412 93 C	01	G- -ARMEE -RTT -ATMOSPHERE POUSSIERES -PISTE	BUTEE CAOUTCHOU ANSCHLAG RUBBER BUFFER TOPE GOMA REGGISPINTA
	A 412 93 B	01	D- -ARMEE -RTT -ATMOSPHERE POUSSIERES -PISTE	-

<b>XT</b>				
51	5 443 730	01	G- -ARMEE -RTT -ATMOSPHERE POUSSIERES -PISTE	BRAS SUSPENSION SCHWINGARM SUSPENSION ARM BRAZO BRACCIO
	5 443 731	01	D- -ARMEE -RTT -ATMOSPHERE POUSSIERES	-

15/02/91  
 1117 03-4260-10  
 PAGE : 1  
 C11 ↑

**MOYEU ARRIERE**  
 HINTERE NABEN  
 REAR HUBS  
 CUBOS TRASEROS  
 MOZZI POSTERIORI

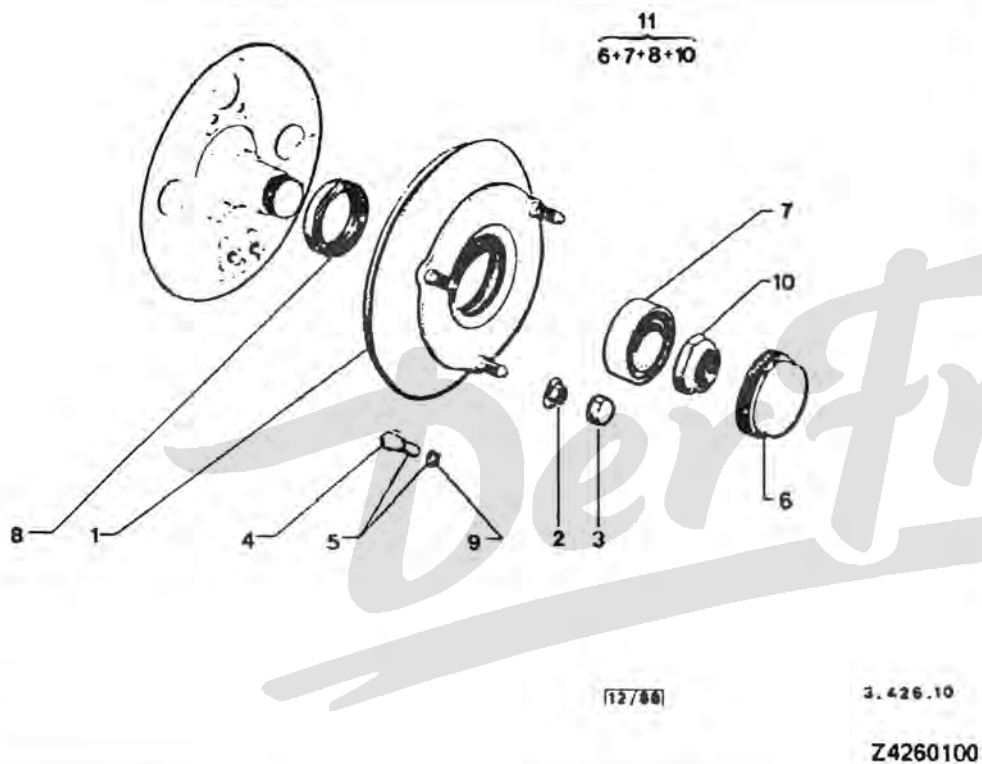

1118 (12/88) 3.426.10  
 Z4260100

02	79 10 034 642	06	12X1,25	2334 ▶	ECROU ROUE TOLE MUTTER STAHLFEL STEEL WHEEL NUT TUERCA DE RUEDA DADO RUOTA LAM
03	79 10 031 881	06			CAPUCHON KAPPE SCREW CAP CAPUCHON CUFFIA
04	96 995 247	06	12X1,25-36		AXE DE FIX ROUE RADBEF.BOLZEN WHEEL FIX SHAFT EJE FIX RUEDA PERNO FISS.RUOT
05	5 429 085	02	ENS		ENS D'AXES ACHSENSATZ SHAFT SET CONJUNTO EJES INS PERNI
06	A 426 97	02	74X1,50		BOUCHON STOPFEN WHEEL HUB PLUG TAPON CUBO TAPPO
	94 584 730	02	SOLUTION REPARATION		-
07	26 200 119	02	35X72X27		ROULEMENT LAGER WHL HUB BEARING RODAMIENTO CUSCINETTO
08	75 532 316	02	45X62X8		BAGUE ANPRESSRING BEARING RING CASQUILLO BOCCOLA
09	95 624 263	06	16X30 E 0,5		RONDELLE SCHEIBE WHL HUB WASHER ARANDELA RONDELLA
10	5 420 544	02	3,1X1,50 H 14,5		ECROU FIX MOYEU MUTTER F.NABE HUB FIXING NUT TUERCA FIX BUJE DADO DEL MOZZO

.../...

01	96 995 256	02	3 TOCS	MOYEU DE ROUE RADNABE WHEEL HUB BUJE DE RUEDA MOZZO RUOTA
02	75 419 948	06	12X1,25 ▶ 05/80	ECROU FIX ROUE RADMUTTER WHEEL MNTG NUT TUERCA DE RUEDA DADO DELLA RUOT
	95 493 339	06	DIAM 12X1,50 06/80 ▶ 2334	-



15/02/91  
1117 03-4260-10  
PAGE : 2  
C12 ↑

**MOYEU ARRIERE**  
HINTERE NABEN  
REAR HUBS  
CUBOS TRASEROS  
MOZZI POSTERIORI

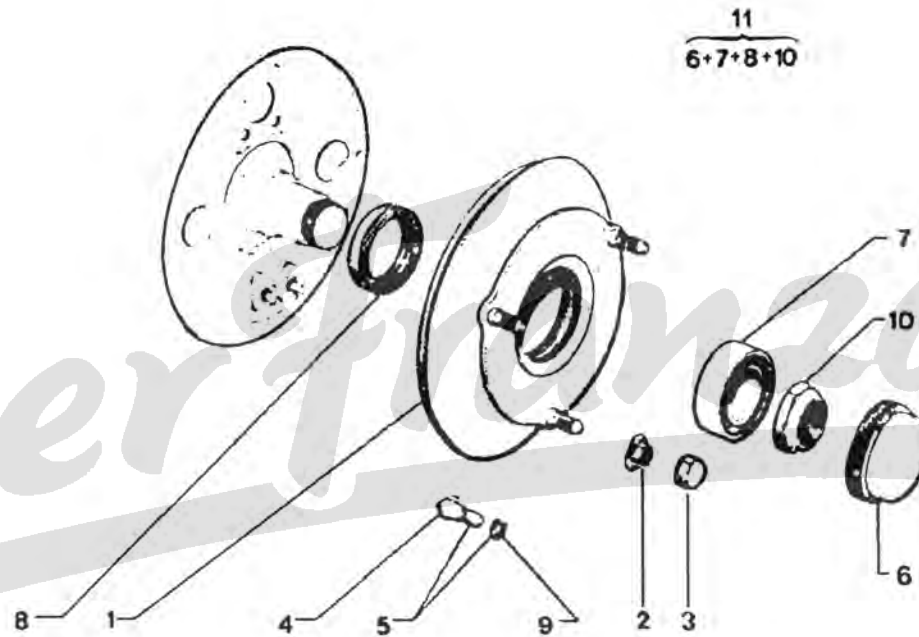

1118

(12/88)

3.426.10

Z4260100

11 \* 75 523 458

02 "PAM"

ENS ROULEMENT  
LAGERSATZ  
HUB BEARING  
CONJ.RODAMIENTO  
INS.CUSCINETTO

15/02/91  
 1117 03-4341-10  
 PAGE : 1  
 C13 ↑

**POTS DE SUSPENSION**  
**FEDERUNGSTOEPFE**  
**SUSPENSION UNITS**  
**TUBOS DE SUSPENSION**  
**CILINDRI DI SOSPENSIONE**

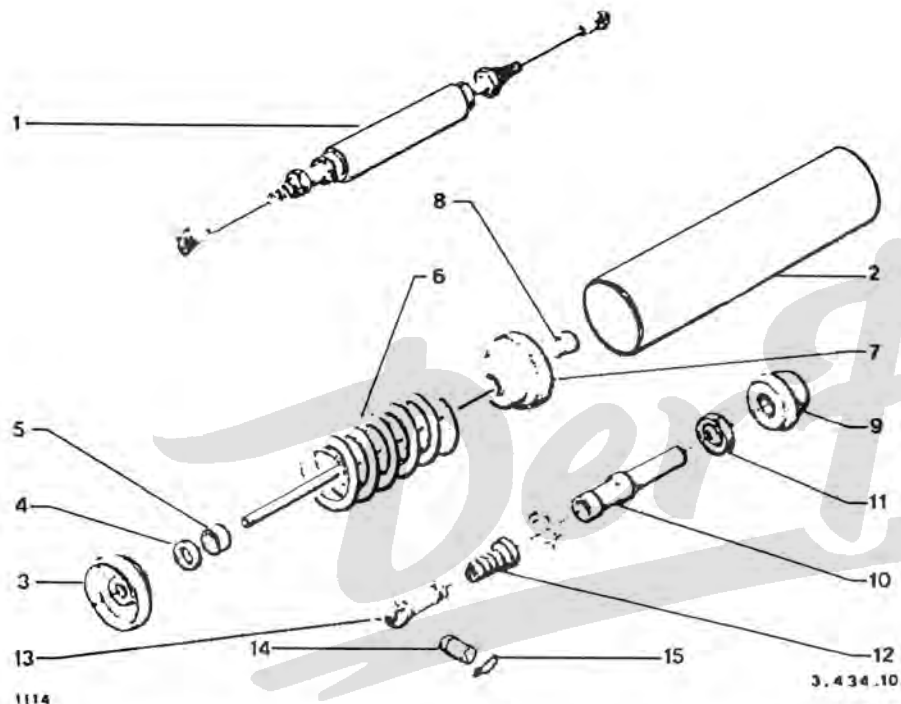

Z4341100

01 \* 5 474 451

02

**POT COMPLET**  
**TOPF KOMPLETT**  
**DAMPER ASSEMBLY**  
**CILINDRO DE SUS**  
**MARMITTA COMPL.**

02 \* AZ 434 99

02 DIAM 109,8-445

**CARTER DE POT**  
**TOPFGEHAEUSE**  
**DASH POT HOUSG**  
**CARTER ESFERA**  
**SCATOLA MARMITT**

03	AZ 434 96	04	DIAM 109	COUPELLE BAGUEE RINGTELLER DAMPER BUSH CUP COPELA ESFERA COPPIGLIA
04	A 434 60	04	27X37X5	RONDELLE FEUTRE FILZSCHEIBE FELT WASHER ARANDELA RONDELLA FELTRO
05	ZC 9612 700 U	04	27.2X31.5X18	BAGUE HALTERING DAMPER RING CASQUILLO BOCCOEA
06	AY 431 1	02	AV DIAM 100 H 193	RESSORT FEDER DAMPER SPRING MUELLE MOLLA
07	5 421 613 A 434 93	02 04	AR DIAM 103,1 DIAM EXT 107	COUPELLE TELLER CENTERING CUP COPELA CENTRAJE SCODELLINO
08	5 424 141 5 424 139	02 02	AV LON 593 AR-LON 632	TIRANT STREBE DAMPER STRUT TIRANTE TIRANTE
09	A 435 1 B	04	DIAM 75	BUTEE ANSCHLAG DASH POT BUFFER TOPE CILINDRO CUSCINETTO
10	AZU 434 288 A	04	AV-AR 36X1,50-181.7	EMBOUT ENDSTUECK END TIE ROD TERMINAL GHIERA
11	AZ 434 87	08	HE 36X1,50	ECROU REGLAGE MUTTER ADJUSTING NUT TUERCA DADO

..!...

15/02/91  
 1117 03-4341-10  
 PAGE : 2  
 C14 ↑

**POTS DE SUSPENSION**  
**FEDERUNGSTOEPFE**  
**SUSPENSION UNITS**  
**TUBOS DE SUSPENSION**  
**CILINDRI DI SOSPENSIONE**

14	A 434 84	02	AV - 41X12	COUTEAU MESSER SUSP END KNIFE TERMINAL SUSPE. COTTELLO
-	AM 434 84 A	02	AR - 43X14	-
15	26 199 649	08	DIAM INT 8.8-32	PINCETTE PINZETTE END PIECE TONG HORQUILLA PINZETTA

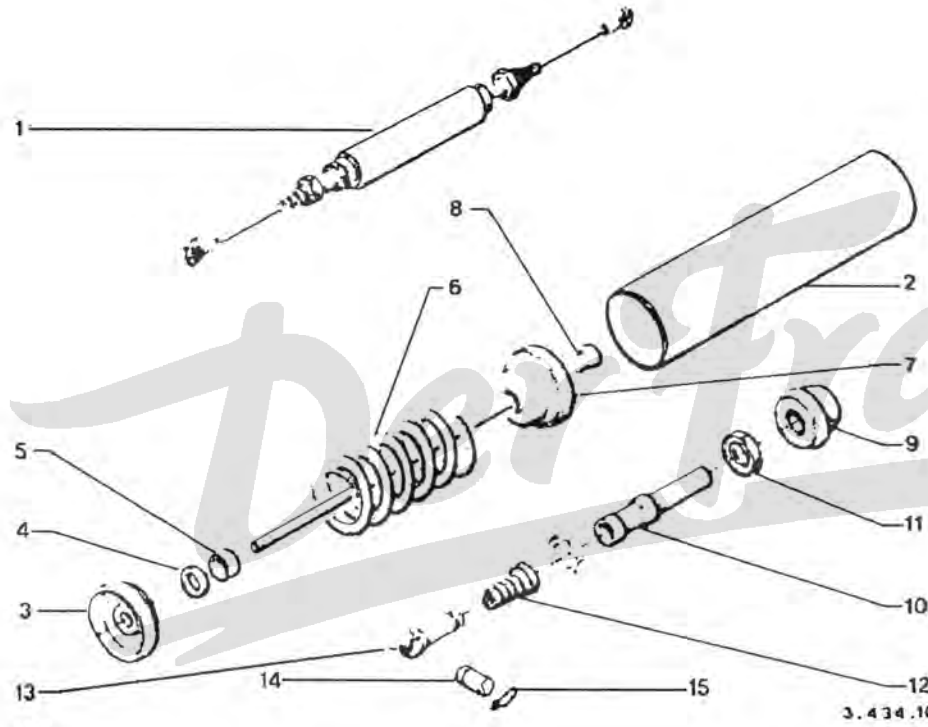

1114

3.434.10

Z4341100

12	5 424 506	04	8X34X60	PARE-POUSSIÈRE STAUBSCHUTZ DUST GUARD GUARDAPOLVOS CUFFIA SOSPEN.
13	5 424 148	04	LON 91	EMBOUT ENDSTUECK END TIE ROD TERMINAL GHIERA

15/02/91  
 1117 03-4360-10  
 PAGE : 1  
 C15 →

**AMORTISSEURS AVANT ET ARRIERE**  
 STOSSDAEMPFER - ANSCHLAEGE  
 SHOCK ABSORBERS - STOPS  
 AMORTIGUADORES - TOPES  
 AMORTIZZATORI - REGGISPINTA

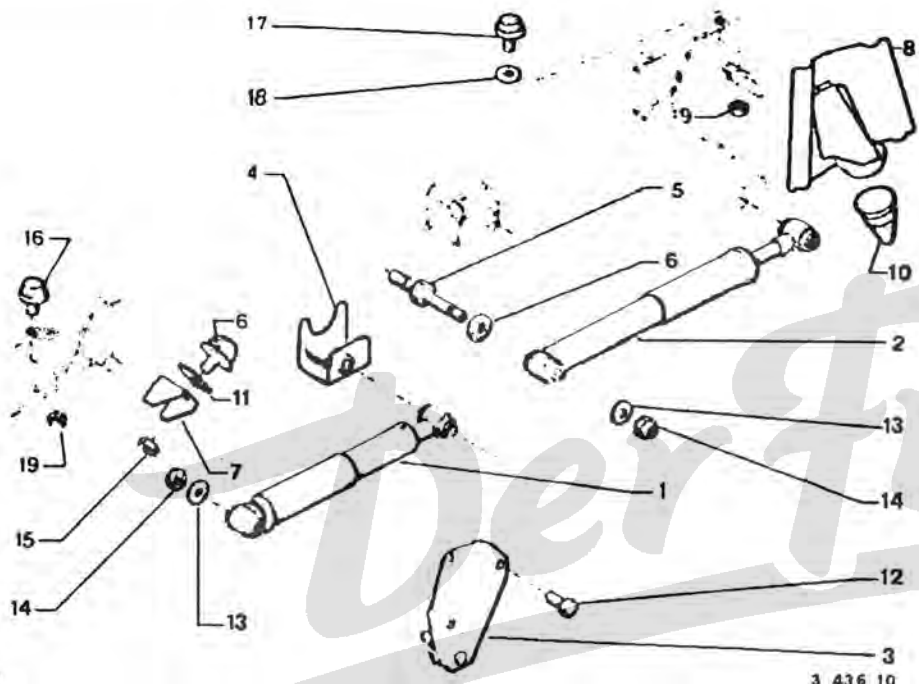

1114

3 436 10  
 Z4360100

- 1 POS : "LIPMESA" - 2 POS : "BOGE"

01	5 490 329	02 AV-1 POS	AMORTISSEUR AV STOSSDAEMPFER V FT SHOCK-ABSORB AMORTIGUADOR AV AMMORTIZZ ANT
	95 494 099	02 AV-2 POS	
02	AZ 436 02	02 AR	AMORTISSEUR AR STOSSDAEMPFER H RR SHOCK-ABSORB AMORTIGUADOR AS AMMORTIZZ POST

03	96 995 230	01 G-	PV DIAM 12X1.25	SUPPORT AMR HALTER SHOCK-AB BRACKT SOPORTE SUPPORTO
	96 995 660	01 D-	AV DIAM 12X1.25	-
04	AZ 436 58 B	02	AVG-ARD 14X150	-
	AZ 436 58 C	02	AVD-ARG 14X1.50	-
05	AM 436 252 A	06	12X1.25.14X1.50-100	AXE BOLZEN FLEX BUSH SHAFT EJE ERNO
06	AM 436 256 A	06	12.1X35X6	ENTRETOISE ABSTANDSSTUECK SHOCK ABS SPACR DISTANCIADOR Distanziale
07	AZ 437 88	01 G-	AV	SUPPORT BUTEE HALTER BLOCK BRACKET SOPORTE TOPE SUPPORTO
	AZ 437 88 A	01 D-	AV	-
08	AY 437 94	01 G-	AR	-
	AY 437 95	01 D-	AR	-
09	AZ 437 86 B	02	AV - DIAM 10X1,50	BUTEE TALONN.AR BEGRENZANSCHLAS REBOUND BLOCK TOPE SUSPENSION CUSCINETTO FOND
10	AY 437 1 A	02	AR	-
11	75 529 370	99	AV-30X42 E 1	CALE DE REGLAGE EINSTELLBEILAGE ADJUSTMENT SHIM CALA REGLAJE SPESSORE REGOL
	AW 437 85	99	AV-30X43 E 4	-

.../...

15/02/91  
 1117 03-4360-10  
 PAGE : 2  
 D15 ↓

**AMORTISSEURS AVANT ET ARRIERE**  
 STOSSDAEMPFER - ANSCHLAEGE  
 SHOCK ABSORBERS - STOPS  
 AMORTIGUADORES - TOPES  
 AMORTIZZATORI - REGGISPINTA

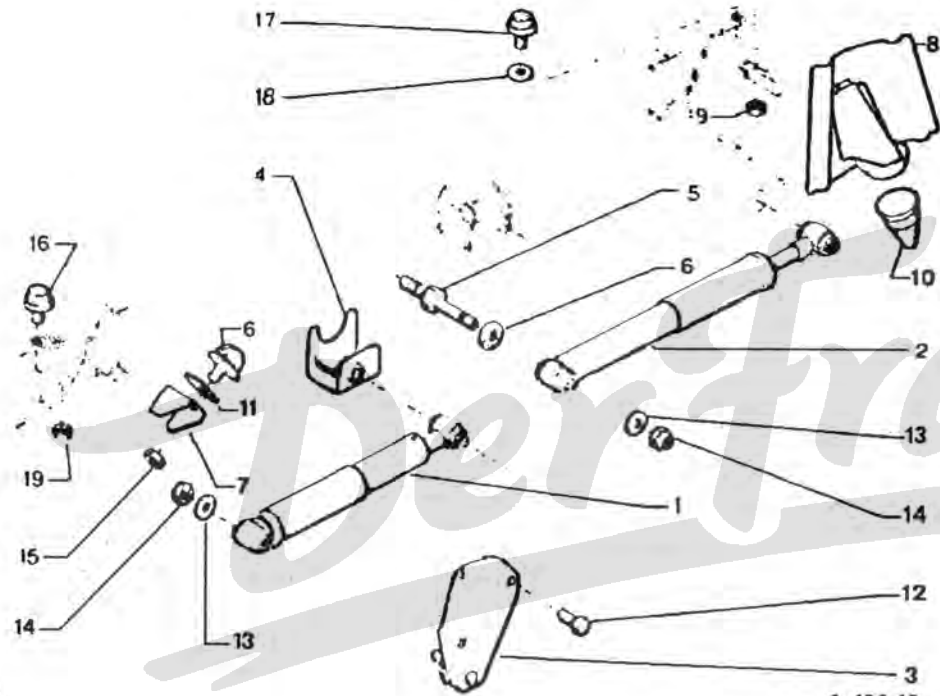

1114

3 436 10

Z4360100

12	23 821 019 RP 23847539	08	TH9X1.25-16	VIS TH SCHRAUBE CAPSCREW TORNILLO TH VITE	14	79 03 234 054 RP 7903234080	08	HEF 12X1 25	ECROU FREIN STOP-MUTTER SELF LOCKG NUT TUERCA FRENADA DADO FRENI
13 *	96 995 249	08	12.1X35 E 2	RONDELLE SCHEIBE WASHER ARANDELA RONDELLA	15 *	25 225 009	02	HE 10X1,50 H 5	ECROU HEXAGONAL SECHSKANTMUTTER HEXAGONAL NUT TUERCA DADO ESAGONALE
					16 *	A 437 1 A	02	AV-7X1.00-15	BUTEE TALONN.AR BEGRENZANSCHLAG REBOUND BLOCK TOPE SUSPENSION CUSCINETTO FOND
					17 *	AZ 437 1 B	02	AR-7X1.00-25	-
					18 *	AZ 437 89 B	02	AR-8X32 E 11,5	CALE DE REGLAGE EINSTELLBEILAGE ADJUSTMENT SHIM CALA REGLAJE SPESSORE REGOL
					19	79 03 032 071	04	H 7 X 1,00 H 3,5 RMP25221019	ECROU HEXAGONAL SECHSKANTMUTTER HEXAGONAL NUT TUERCA DADO ESAGONALE
								<b>XT</b>	
					66 *	AZ 437 1 B	02	AR-7X1.00-25 -RTT -ATMOSPHERE POUSSIERES -PISTE	BUTEE TALONN.AR BEGRENZANSCHLAG REBOUND BLOCK TOPE SUSPENSION CUSCINETTO FOND
					67 *	AZ 437 89 B	02	AR-8X32 E 11,5 -ARMEE -RTT -ATMOSPHERE POUSSIERES -PISTE	CALE DE REGLAGE EINSTELLBEILAGE ADJUSTMENT SHIM CALA REGLAJE SPESSORE REGOL
					68	79 03 032 071	04	H 7 X 1,00 H 3,5 -ARMEE -RTT -ATMOSPHERE POUSSIERES -PISTE	ECROU HEXAGONAL SECHSKANTMUTTER HEXAGONAL NUT TUERCA DADO ESAGONALE

15/02/91  
 1117 03-4410-10  
 PAGE : 1  
 D14 ↓

**DIRECTION - VOLANT**  
 LENKRAD  
 STEERING WHEEL  
 DIRECCION - VOLANTE  
 STERZO - VOLANTE

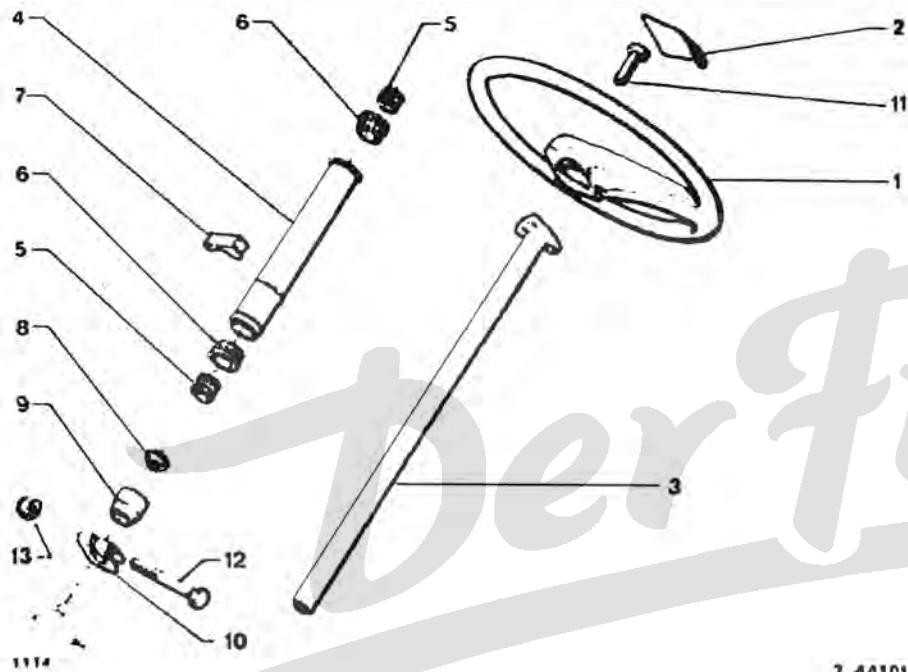

3.4410100

24410100

01	* 5 476 861*700	01	DIAM 390	VOLANT LENKRAD STEERING WHEEL VOLANTE VOLANTE STERZO
02	* 5 490 700*700	01		COUSSIN VOLANT POLSTERUNG CUSHIONING PAD ALMOHADILLA CUSCINETTO
	* 5 490 544*700	01	-SPECIALE	-

03	* 95 559 539	01	LON 744 1515 ▶	AXE DE VOLANT LENKSPINDEL STRG WHL SHAFT EJE INF CARDAN PERNO VOLANTE
04	* 5 474 070 XA	01	LON 329	SUPPORT COLONNE TRAEGER COLUMN SUPPORT SOPORTE COLUMNA SUPPORTO
05	* 5 420 180	02	24X30X25	BAGUE D'AXE RING F.ACHSE SHAFT RING CASQUILLO COLUM BOCCOLA PERNO
06	* A 441 83 A	02	26.5X36.7X25.5	BAGUE ELASTIQUE RING BUSHING CASQUILLO ELAS BOCCOLA ELAST.
07	* AZ 441 4	99	28X42 E 5	SUPPORT ELASTI. HALTER ELASTIC BRACKET SOPORTE BOCCOLA ELAST.
	* AZ 441 4 A	99	28X42 E 6	-
	* AZ 441 4 B	99	28X42 E 11	-
	AZ 441 4 C	99	28X42 E 14	-
	95 631 249	99	28X42 E 17	-
08	* AY 441 94	01	24X31X6	BAGUE D'AXE RING F.ACHSE SHAFT RING CASQUILLO COLUM BOCCOLA PERNO
09	* 5 410 642	01	DIAM EXT 54	-
10	* 5 401 947	0	DIAM 23,7	COLLIER METAL METALLSCHELLE METALLIC CLAMP ABRAZADERA COLLARE METALL

.../...

15/02/91  
 1117 03-4410-10  
 PAGE : 2  
 D13 ↓

**DIRECTION - VOLANT**  
**LENKRAD**  
**STEERING WHEEL**  
**DIRECCION - VOLANTE**  
**STERZO - VOLANTE**

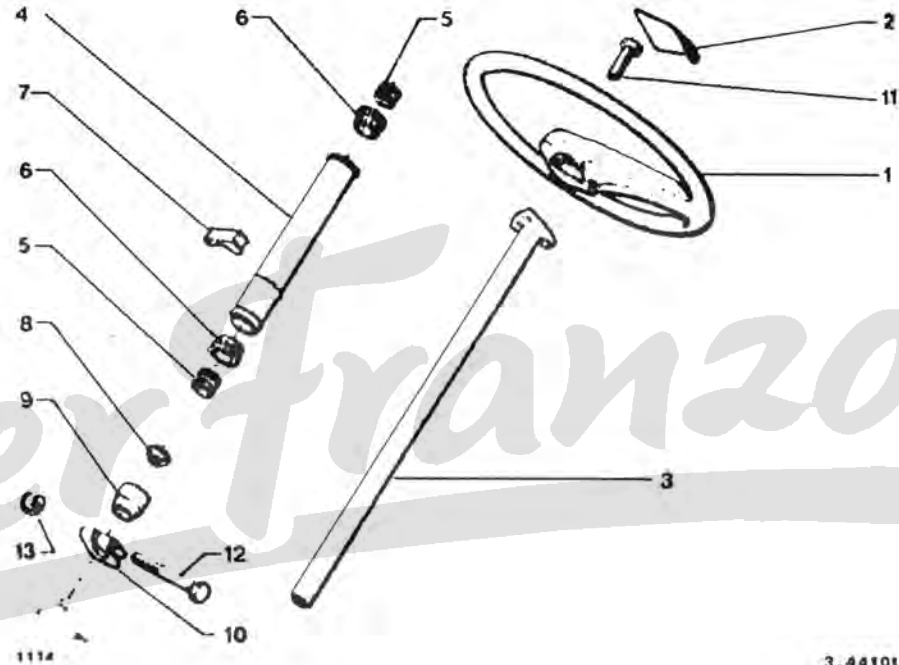

3.4410100

Z4410100

11	79 03 101 752	03	DIAM 7X100-12	VIS TH SCHRAUBE CAPSCREW TORNILLO TH VITE
12	26 211 659	01	TH 7-50	-
13	79 03 034 085	01	HEF 7X1,00	1891 ► ECROU FREIN STOP-MUTTER SELF LOCKG NUT TUERCA FRENADA DADO FRENI

15/02/91  
 1117 03-4415-10  
 PAGE : 1  
 D12 ↓

**ANTIVOL**  
**DIEBSTAHLSICHERUNG**  
**ANTI-THEFT DEVICE**  
**ANTIRROBO**  
**ANTIFURTO**

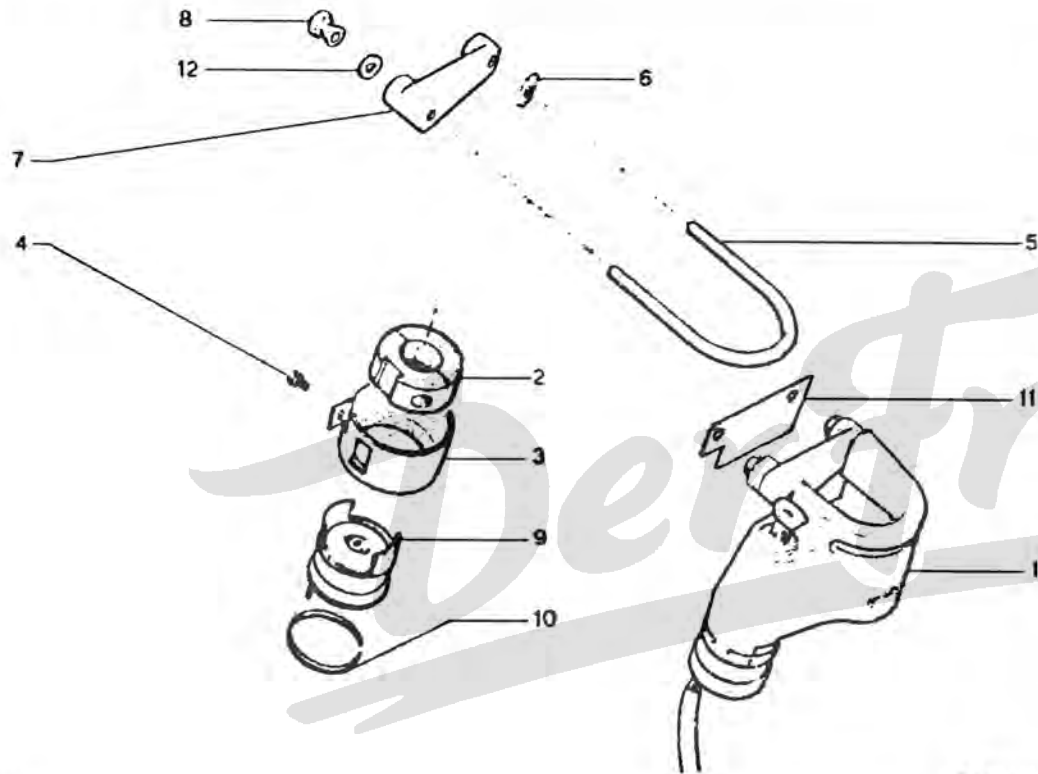

1114

3.611.10  
 Z4415100

01	*	95 495 241	01		1515 ▶	ANTIVOL ZUENDSCHLOSS STEERING LOCK ANTIRROBO ANTIFURTO	03	*	5 410 509	01	DIAM EXT 51,5	DOUILLE BUECHSE SOCKET CASQUILLO BOCCOLA
02	*	5 410 508	01	23,5X45X17		BAGUE D'AXE RING F.ACHSE SHAFT RING CASQUILLO COLUM BOCCOLA PERNO	04	*	AZ 611 104	01	TH 4X0,70-6	VIS TH SCHRAUBE CAPSCREW TORNILLO TH VITE
							05	*	AZ 611 57 A	01	H 83	ETRIER MAINTIEN BUEGEL U BOLT SOPORTE STAFFA
							06	*	AZ 611 50	99	13X20X3	CALE DE REGLAGE EINSTELLBEILAGE ADJUSTMENT SHIM CALA REGLAJE SPESSORE REGOL.
							07	*	95 631 288	01	ENTR'AXES 54	CONTREPLAQUE GEGENPLATTE COUNTERPLATE CONTRAPLACA CONTROPIASTRA
							08	*	AZ 611 73	02	HE 7X1,00 H14	ECROU D'ANTIVOL MUTTER LOCK NUT TUERCA DADO
							09	*	5 500 731	01	3 FICHES MALES	CONTACTEUR SCHALTER CONTACT SWITCH CONTACTOR CONTATTORE
							10	*	5 470 476	01		JONC D'ARRET HALTERING CIRCLIP ANILLO DE TOPE ANELLO ARRESTO
							11	*	75 511 048	01	2 DIAM 8	CACHE AMOVIBLE ABDECKUNG LOCK COVER TAPA ANTI-ROLO TAPPO

.../...



15/02/91  
1117 03-4415-10  
PAGE : 2  
D11 ↓

**ANTIVOL**  
DIEBSTAHLSICHERUNG  
ANTI-THEFT DEVICE  
ANTIRROBO  
ANTIFURTO

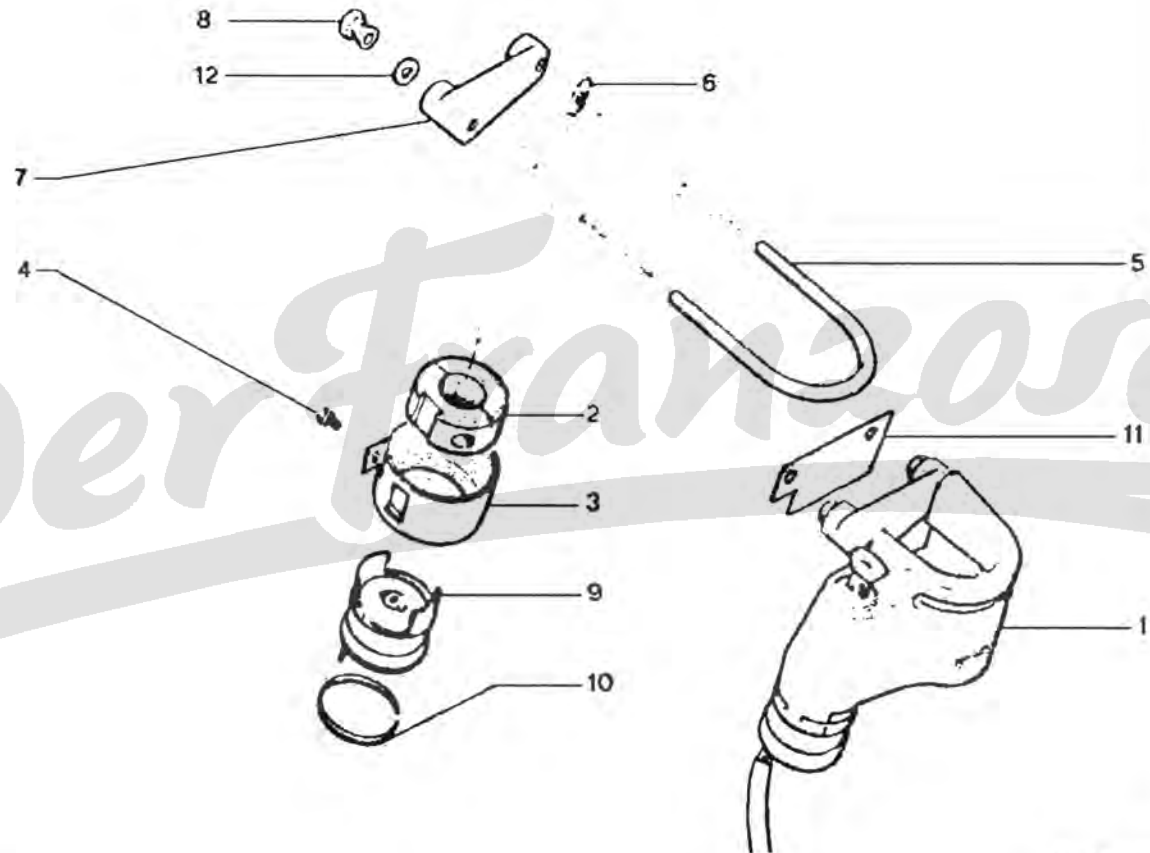

1114

3.611.10  
Z4415100

12 79 03 058 011

02 DIAM 7,2X14,2-1,4

RONDELLE CONIQU  
KONUSSCHEIBE  
SPRING WASHER  
ARANDELA  
RONDELLA CONICA

15/02/91  
 1117 03-4419-10  
 PAGE : 1  
 D10 ↓

**DIRECTION - BARRES**  
 SPURSTANGEN  
 STEERING RODS  
 DIRECCION - BARRAS  
 STERZO - BARRE

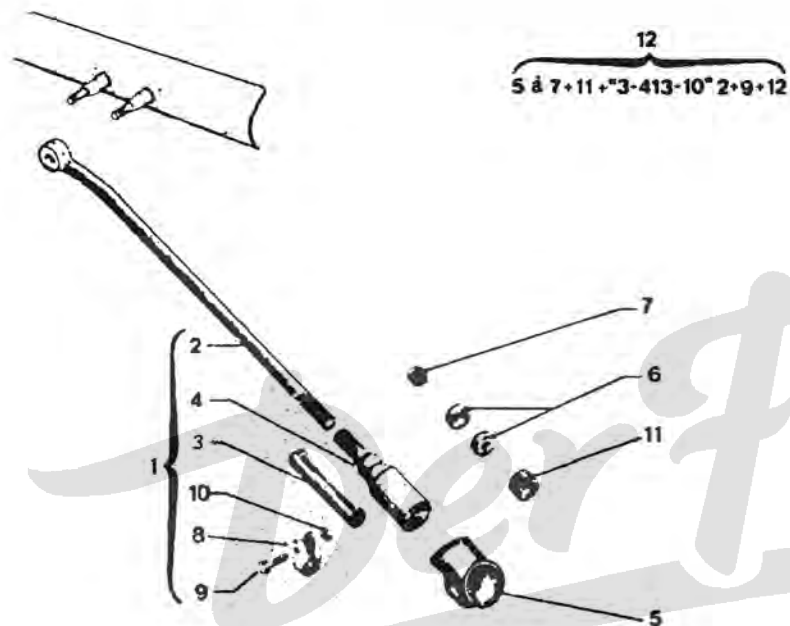

1114

3.443.10  
 Z4419100

01	A 443 1 G	01 G- COMPLETE	BARRE DE RENVOI UMLENKSTANGE RELAY BAR BARRA REZNVIO BARRA DI RINVIO
	A 443 1 J	01 D- COMPLETE	-
02	A 443 97 D	02 NUE LON 497	-

03	5 411 821 RP AM44310A	02 DIAM 14X1,25-80	MANCHON MUFFE STUD SLEEVE MANGUITO MANICOTTO
04	A 443 98 B	01 G- 14X1,25-112	EMBOUT ENDSTUECK END PIECE PROTECTOR BIELA TERMINALE
	A 443 98 C	01 D- 14X1,25-112	-
05	A 443 13 B	02	CAINE SCHUTZHUELLE PROTECT SHEATH VAINA GUAINA
06	AZ 443 2	04 DIAM 22 H 7,5	SIEGE DE ROTULE SITZ BALL-JOINT SEAT ASIEN TO ROTULA SEDE ROTULA
07	5 419 952	02 DIAM 18-17	RESSORT FEDER SPRING MUELLE MOLLA
08	5 411 922	04 DIAM 17,7	COLLIER SCHELLE STRUT COLLAR ABRAZADERA COLLARE
09	79 03 101 806	04 TH 7X1,00-30	VIS TH SCHRAUBE CAPSCREW TCRNILLO TH VITE
10	79 03 032 036	04 HE 7X1,00-5,5	ECROU MUTTER NUT TUERCA DADO
11	5 419 953	02 DIAM 24X1,50 H 12	VIS DE POUSSOIR STOESS.SCHRAUBE PISTON SCREW TORNILLO VASTAG VITE PUNTERIA

.../...

15/02/91  
 1117 03-4419-10  
 PAGE : 2  
 D09 ↓

**DIRECTION - BARRES**  
 SPURSTANGEN  
 STEERING RODS  
 DIRECCION - BARRAS  
 STERZO - BARRE

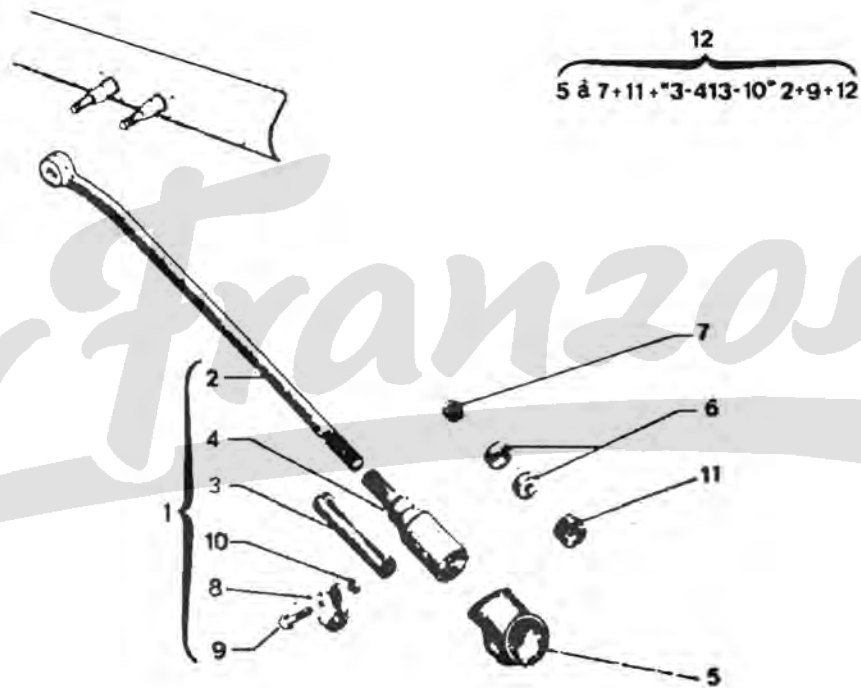

1114

3.443.10  
 Z4419100

12 \* 5 467 697  
 NFP

01 G- ENS

NEC DE RENVOI  
 REP-SATZ UMLENK  
 STRG RETURN KIT  
 JUEGO REENVIO  
 NECESSARIO

\* 5 467 698  
 NFP

01 D- ENS

-

15/02/91  
 1117 03-4423-10  
 PAGE : 1  
 D08 ↓

**DIRECTION - PIGNON - GLISSIERE**  
 LENKUNG - RITZEL - FUEHRUNG  
 STEERING - PINION AND SLIDE  
 DIRECCION - PINON - DESLIZADERA  
 STERZO - PIGNONE - SLITTA

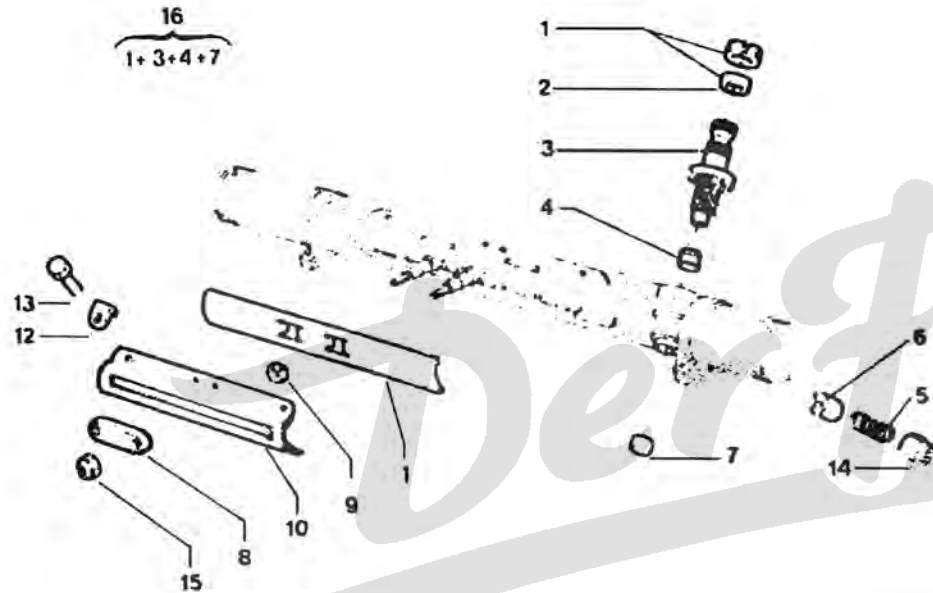

03	95 598 145	01	8 DENTS	PIGNON RITZEL STEERING PINION PINON PIGNONE
04	5 436 648	01	9.5X13.3X3.2	JOINT DE PIGNON RITZELDICHUNG PINION SEAL JUNTA DE PINON GUARNIZIONE PIG
05	5 419 951	01	DIAM EXT 16.5	RESSORT FEDER PISTON SPRING MUELLE MOLLA
06	AM 442 1 A	01	LON 24.5	POUSSOIR STOESSEL RACK PISTON VASTAGO PUNTERIA
07	26 204 369	01	DIAM 10X16X12	ROULEMENT LAGER PINION BEARING RODAMIENTO CUSCINETTO
08	AZ 442 75	01	22X70X8	PLAQUETTE PLAKETTE STRG HSG PLATE PLAQUETA PIASTRA
09	AZ 442 76	02	8X20X20 DIAM INT 13	DE DE GUIDAGE WUERFEL GUIDE DIE DADO DE GUIA DADO DI GUIDA
10	A 442 78 A	01	LON 251	GLISSIERE SCHIENE COVER SLIDE CORREDERA GUIDA
11	A 442 79	01	LON 310	CACHE MOBILE KUGELKAPPE MOBILE COVER TAPA MOVIL TAPPO

01 \* 5 502 740 01 DIAM 38X1.50 H 11

ECROU + JOINT  
 MUTTER  
 SEAL + NUT  
 TUERCA + JUNTA  
 DADO + GUARNIZ

02 26 125 609 01 DIAM 19X27X5

JOINT DE PIGNON  
 RITZELDICHUNG  
 PINION SEAL  
 JUNTA DE PINON  
 GUARNIZIONE PIG

.../...

15/02/91  
 1117 03-4423-10  
 PAGE : 2  
 D07 ↓

**DIRECTION - PIGNON - GLISSIERE**  
 LENKUNG - RITZEL - FUEHRUNG  
 STEERING - PINION AND SLIDE  
 DIRECCION - PINON - DESLIZADERA  
 STERZO - PIGNONE - SLITTA

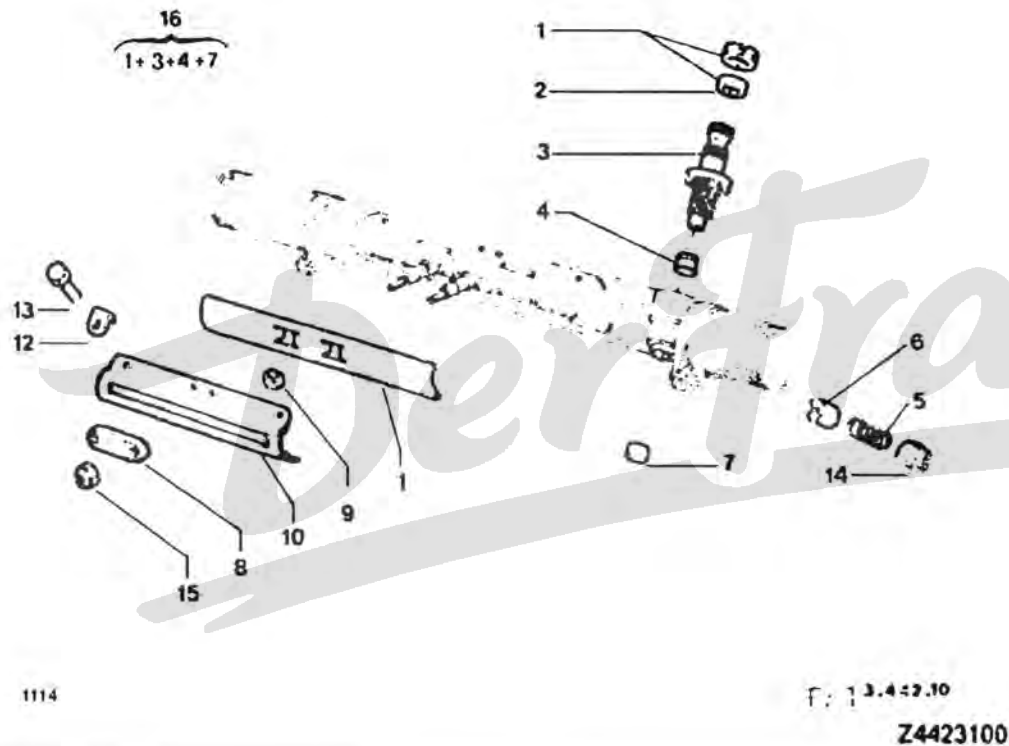

14	5 419 953	01	DIAM 24X1,50 H 12	VIS DE POISSOIR STOESS SCHRAUBE PISTON SCREW TORNILLO VASTAG VITE PUNTERIA
15	79 03 234 011	02	DIAM 10X1,50 H12	ECROU FREIN STOP-MUTTER SELF LOCKG NUT TUERCA FREIHADA DADO FRENI
16	5 504 022	01	ENS "PAM" 8 DENTS	NEC REP. PIGNON REPARATURSATZ REPAIR KIT JUEGO REPARACI OCCURR.RIPARAZ
59	AM 442 76 A	02	20X20X8,75 DIAM 13 -ARMEE -RTT -CAD -PISTE	<b>XT</b> DE DE GUIDAGE WUERFEL GUIDE DIE DADO DE GUIA DADO DI GUIDA
60	5 416 746	01	LON 236,5 -ARMEE -RTT -CAD -PISTE	GLISSIERE SCHIENE COVER SLIDE CORREDERA GUIDA
61	AM 442 79	01	LON 319 -ARMEE -RTT -CAD -PISTE	CACHE MOBILE KUGELKAPPE MOBILE COVER TAPA MOVIL TAPPO

12	A 442 35	04	DIAM 7,5	ARRETOIR ARRETIERUNG RETAINER RETEN ARRESTO
13	79 03 101 752	04	DIAM 7X100-12	VIS TH SCHRAUBE CAPSCREW TORNILLO TH VITE

15/02/91  
1117 03-4424-10  
PAGE : 1  
D06 ↓

**DIRECTION CREMAILLERE**  
**LENKUNGSZAHNSYANGE**  
**STEERING RACK**  
**DIRECCION - CREMALLERA**  
**STERZO - CREMAGLIERA**

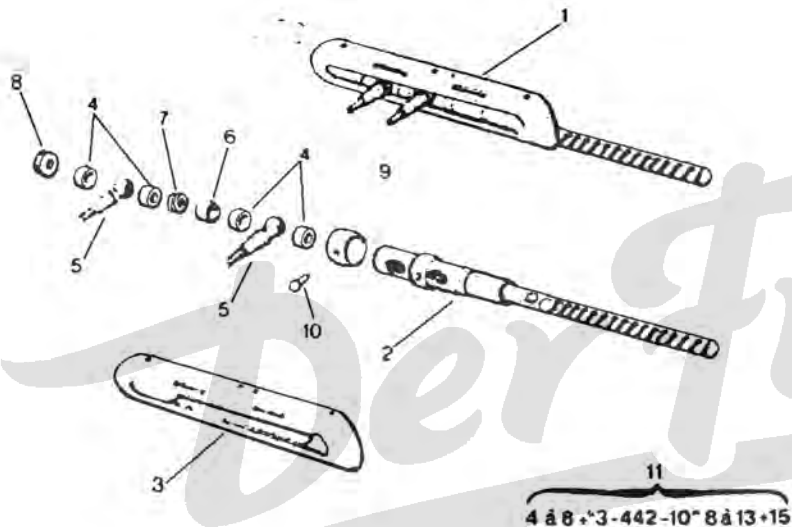

1114

3-442-20

24424100

04	AZ 443 2	04	DIAM 22 H 7.5	SIEGE DE ROTULE SITZ BALL-JOINT SEAT ASIENTO ROTULA SEDE ROTULA
05	AM 442 8	02	DIAM*10X1.50-71	ROTULE KUGELGELENK STRG TIE-ROD ROTULA ROTULA
06	A 442 84	01	14X19 H 22	GLISSIERE SCHIENE COVER SLIDE CORREDERA GUIDA
07	5 419 952	01	DIAM 18-17	RESSORT FEDER SPRING MUELLE MOLLA
08	AM 442 83	01	24X1,50 H 9	ECROU MUTTER NUT TUERCA DADO
09	A 442 97 A	01	DIAM EXT 34	ROTULE KUGELGELENK STRG TIE-ROD ROTULA ROTULA
10	A 442 74	01	DIAM 4-7	RIVET NIET RIVET REMACHE RIVETTO
01	5 471 955	01	COMPLETE	CREMAILLERE ZAHNSTANGE STEERING RACK CREMALLERA CREMAGLIERA
02	95 587 300	01	NUE	2276 ▶
03	AZ 442 80	01	LON 284	GUIDE DE ROTULE FUEHRUNG BALL-JOINT GUID GUIA ROTULA GUIDA
04	5 453 806	01	ENS	NEC REPARATION REPARATURSATZ REPAIR KIT JUEGO REPARACI NECESS RIPARAZ
51	5 427 310	01	COMPLETE -ARMEE -RTT -PISTE	<b>XT</b> CREMAILLERE ZAHNSTANGE STEERING RACK CREMALLERA CREMAGLIERA

.../...

15/02/91  
 1117 03-4424-10  
 PAGE : 2  
 D05

**DIRECTION CREMALLERE**  
**LENKUNGSZAHNSYANGE**  
**STEERING RACK**  
**DIRECCION - CREMALLERA**  
**STERZO - CREMAGLIERA**

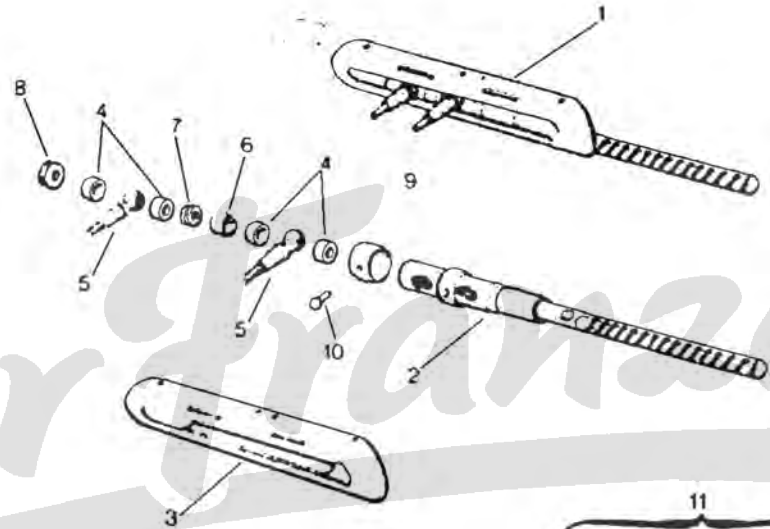

1114

11  
 4 à 8 + 3-442+10 + 8 à 13+15

3.442.20

24424100

51	*	5 471 954	01	COMPLETE -CAD	CREMALLERE ZAHNSTANGE STEERING RACK CREMALLERA CREMAGLIERA
52	*	95 587 301	01	NUE -CAD	-
53	*	AM 442 80	01	LON 289 -ARMEE -RTT -PISTE	GUIDE DE ROTULE FUEHRUNG BALL-JOINT GUID GUIA ROTUI A GUIDA

227e ▶

NUMERO	SOUS-GROUPE	REP	NUMERO	SOUS-GROUPE	REP	NUMERO	SOUS-GROUPE	REP	NUMERO	SOUS-GROUPE	REP
5 401 947	03-4410-10	10	5 504 947		52	5 474 070 XA	03-4410-10	04	AM 434 84 A	03-4341-10	14
5 410 508	03-4415-10	02	5 504 948		52	5 476 861 700		01	AM 436 252 A	03-4360-10	05
5 410 509		03	5 504 969		01	5 490 544 700		02	AM 436 256 A		06
5 410 642	03-4410-10	09	5 504 970		51	5 490 700 700		02	AM 442 1 A	03-4423-10	06
5 411 821	03-4419-10	03	5 504 971		51	A 412 93	03-4229-10	03	AM 442 76 A		53
5 411 822		08	22 600 019	03-4160-10	13		03-4120-10	05	AM 442 79		61
5 416 746	03-4423-10	60	23 746 509	03-4130-10	13	A 412 93 A		05	AM 442 8	03-4424-10	05
5 419 951		05	23 821 019	03-4260-10	12		03-4229-10	03	AM 442 80		53
5 419 952	03-4419-10	07	23 826 315	03-4120-10	10	A 412 93 B		53	AM 442 83		05
	03-4424-10	07	24 737 019	03-4130-10	12		03-4120-10	55	AU 424 97 A	03-4229-10	04
5 419 953	03-4419-10	11	25 223 019	03-4120-10	13	A 412 93 C		55	AW 437 85	03-4360-10	11
	03-4423-10	14	25 225 009	03-4360-10	15		03-4229-10	53	AY 431 1	03-4341-10	06
5 420 180	03-4410-10	05	26 125 609	03-4423-10	02	A 413 2	03-4130-10	03	AY 437 1 A	03-4360-10	10
5 420 543	03-4160-10	18	26 199 649	03-4341-10	15	A 413 3 B		04	AY 437 94		08
5 420 544	03-4260-10	10	26 200 119	03-4160-10	10	A 413 5 A		05	AY 437 95		08
5 421 613	03-4341-10	06		03-4260-10	07	A 413 7		06	AY 441 94	03-4419-10	08
5 424 139		08	26 204 369	03-4423-10	07	A 413 7 A		06	AY 854 1	03-4160-10	14
5 424 141		08	26 277 519	03-4120-10	09	A 413 7 B		06	AZ 414 90	03-4120-10	11
5 424 148		13		03-4229-10	10	A 413 8		07	AZ 416 01	03-4160-10	01
5 424 506		12	26 211 659	03-4410-10	12	A 413 9		08	AZ 416 84		11
5 427 310	03-4424-10	51	75 416 826	03-4160-10	16	A 413 90		10	AZ 424 96	03-4229-10	06
5 428 292	03-4120-10	04	75 419 948		04	A 413 95		11	AZ 434 87	03-4341-10	11
5 429 085	03-4260-10	05		03-4260-10	02	A 414 89	03-4229-10	05	AZ 434 96		03
5 436 648	03-4423-10	04	75 491 339	03-4160-10	07		03-4120-10	07	AZ 434 99		02
5 443 708	03-4229-10	01	75 511 048	03-4415-10	11	A 416 59	03-4160-10	03	AZ 436 02	03-4360-10	02
5 443 709		01	75 523 458	03-4260-10	11	A 426 97	03-4260-10	06	AZ 436 58 B		04
5 443 730		51	75 529 370	03-4360-10	11	A 434 60	03-4341-10	04	AZ 436 58 C		04
5 443 731		51	75 532 316	03-4260-10	08	A 434 84		14	AZ 437 1 B		17
5 451 358	03-4130-10	14		03-4160-10	09	A 434 93		07			66
5 451 859	03-4160-10	12	94 584 730	03-4260-10	06	A 435 1 B		09	AZ 437 86 B		09
5 453 806	03-4424-10	11	95 493 339		02	A 437 1 A	03-4360-10	16	AZ 437 88		07
5 458 682	03-4160-10	06	95 494 099	03-4360-10	01	A 437 89	03-4120-10	06	AZ 437 88 A		07
5 467 697	03-4419-10	12	95 495 241	03-4415-10	01	A 441 83 A	03-4410-10	06	AZ 437 89 B		18
5 467 698		12	95 544 122	03-4160-10	03	A 442 74	03-4424-10	10			67
5 470 476	03-4415-10	10	95 555 539	03-4410-10	03	A 442 78 A	03-4423-10	10	AZ 441 4	03-4410-10	07
5 471 866	03-4120-10	03	95 568 931	03-4229-10	09	A 442 79		11	AZ 441 4 A		07
5 471 868		53		03-4120-10	08	A 442 84	03-4424-10	06	AZ 441 4 B		07
5 471 370		53	95 569 500	03-4130-10	02	A 442 95	03-4423-10	12	AZ 441 4 C		07
5 471 954	03-4424-10	51	95 569 501		02	A 442 97 A	03-4424-10	09	AZ 442 75	03-4423-10	08
5 471 955		01	95 587 300	03-4424-10	02	A 443 1 G	03-4419-10	01	AZ 442 76		09
5 474 451	03-4341-10	01	95 587 301		52	A 443 1 J		01	AZ 442 80	03-4424-10	03
5 474 954	03-4160-10	15	95 598 145	03-4423-10	03	A 443 13 B		05	AZ 443 2		04
5 490 329	03-4360-10	01	95 623 739	03-4130-10	13	A 443 97 D		02		03-4419-10	06
5 500 731	03-4415-10	09	95 624 263	03-4260-10	09	A 443 98 B		04	AZ 611 104	03-4415-10	04
5 502 003	03-4130-10	01	95 631 249	03-4410-10	07	A 443 98 C		04	AZ 611 50		06
5 502 740	03-4423-10	01	95 631 289	03-4415-10	07	AM 413 89	03-4130-10	09	AZ 611 57 A		05
5 504 022		16	96 995 230	03-4360-10	03	AM 414 91	03-4120-10	12	AZ 611 73		08
5 504 937	03-4120-10	02	96 995 247	03-4260-10	04		03-4229-10	08	AZU 434 288 A	03-4341-10	10
5 504 938		02	96 995 249	03-4360-10	13	AM 416 4 A	03-4160-10	02	ZC 9612 700 U		05
5 504 939		52	96 995 256	03-4260-10	01	AM 422 50 A	03-4229-10	07	ZC 9615 862 U	03-4160-10	17
5 504 940		52	96 995 660	03-4360-10	03	AM 424 01 B		02	79 03 032 036	03-4419-10	10



**B04 ↑****INDEX****Catalogue 1117**

<b>NUMERO</b>	<b>SOUS-GROUPE</b>	<b>REP</b>
79 03 032 071	03-4360-10	19
		68
79 03 034 085	03-4410-10	13
79 03 058 011	03-4415-10	12
79 03 101 752	03-4410-10	11
	03-4423-10	13
79 03 101 806	03-4419-10	09
79 03 234 011	03-4423-10	15
79 03 234 054	03-4360-10	14
79 10 031 881	03-4160-10	19
	03-4260-10	03
79 10 034 642		02
	03-4160-10	05

<b>15/02/91</b> <b>1117</b> <b>TABLEAU DES VUES</b> <b>AUFSTELLUNG DER BILDER</b> <b>TABLE OF PICTURE</b> <b>B01 ↑</b> <b>TABLA DE VISTAS</b> <b>TABELLA DELLE VEDUTE</b>	<b>GRUPE</b> <b>GROUP</b> <b>GROUP 04</b> <b>GRUPO</b> <b>GRUPPO</b>		<b>MAITRE CYLINDRE TANDEM - RESERVOIR</b> <b>TANDEM-HAUPTBREMSZYLINDER-BEHAELTER</b> <b>TANDEM MASTER CYLINDER-TANK</b> <b>BOMBA PRINCIPAL TANDEM DEPOSITO</b> <b>CILINDRO MAESTRO TANDEM SERBATOIO</b> - ► 1665 - 1666 ►	4535-10 4535-20	D13 D12
<b>SOUS-GROUPE</b> <b>UNTERGRUPPE</b> <b>SUBGROUP</b> <b>SUBGRUPO</b> <b>SOTTOGRUPPO</b>	<b>NUMERO</b> <b>NUMMER</b> <b>NUMBER</b> <b>NUMERO</b> <b>NUMERO</b>	<b>VUE</b> <b>BILD</b> <b>PICTURE</b> <b>VISTA</b> <b>VEDUTA</b>	<b>CYLINDRE DE ROUE AVANT</b> <b>RADZYLINDER - VORN</b> <b>WHEEL CYLINDERS - FRONT</b> <b>BOMBINES DE RUEDAS DELANTEROS</b> <b>CILINDRETTI RUOTE - ANTERIORE</b> - ► 1665	4536-10	D11
<b>EDALIER - FREIN - DEBRAYAGE</b> <b>EDALWERK - BREMSE - KUPPLUNG</b> <b>EDAL GEAR - BRAKE - CLUTCH</b> <b>OPORTE DE PEDALES EMBRAGUE</b> <b>EDALIERA - FRENO - FRIZIONE</b> ► 1665 1666 ►	3140-10 3140-11	C02 C03 C04 C05	<b>CYLINDRE DE ROUE ARRIERE</b> <b>HINTERE RADZYLINDER</b> <b>REAR WHEEL CYLINDER</b> <b>BOMBIN DE RUEDA TRAS.</b> <b>CILINDRETTO RUOTA POST</b> - ► 1665 - 1666 ►	4537-10 4537-20	D10 D09
<b>RANSMISSIONS A BILLES</b> <b>UGELGELENKWELLEN</b> <b>ALL DRIVESHAFTS</b> <b>RANSMISIONES DE BOLAS</b> <b>RANSMISSIONI A SFERE</b>	3733-10	C06 C07	<b>FREIN A MAIN - TIRETTE</b> <b>HANDBREMSE - ZUGSTANGE</b> <b>HAND BRAKE - CONTROL ROD</b> <b>FRENO DE MANO - TIRADOR</b> <b>FRENO A MANO - TIRANTE</b> - ► 1665 - 1666 ►	4550-10 4550-20	D08 D07 D06 D05
<b>REINS AVANT - ETRIERS ET DISQUES</b> <b>ORDERE BREMSEN - GABELN UND SCHEIBEN</b> <b>FRONT BRAKES - CALIPERS AND DISCS</b> <b>RENOS DELANTEROS - CALIPERES Y DISCOS</b> <b>RENI ANTERIORI - PIKZE E DISCHI</b> ► 1665 1666 ►	4512-10 4512-11	C08 C09 C10 C11	<b>FREIN A MAIN - LEVIER - CABLES</b> <b>HANDBREMSE - HEBEL - SEILE</b> <b>HANDBRAKE - LEVER - CABLES</b> <b>FRENO DE MANO - PALANCA - CABLES</b> <b>FRENO A MANO - LEVA - CAVI</b> - 1666 ►	4555-10	D04 D03
<b>REIN ARRIERE</b> <b>HINTERE BREMSE</b> <b>REAR BRAKE</b> <b>RENOS TRASERO</b> <b>RENI POSTERIORI</b>	4515-20	C12 C13			
<b>ANALISATIONS DE FREIN</b> <b>REIMSLEITUNGEN</b> <b>BRAKE PIPINGS</b> <b>ANALIZACIONES DE FRENO</b> <b>ANALIZZAZIONI FRENO</b> ► 1665 1666 ►	4530-10 4530-15	C14 C15 D15 D14			

**PEDALIER - FREIN - DEBRAYAGE**  
**PEDALWERK - BREMSE - KUPPLUNG**  
**PEDAL GEAR - BRAKE - CLUTCH**  
**SOPORTE DE PEDALES EMBRAGUE**  
**PEDALIERA - FRENO - FRIZIONE**

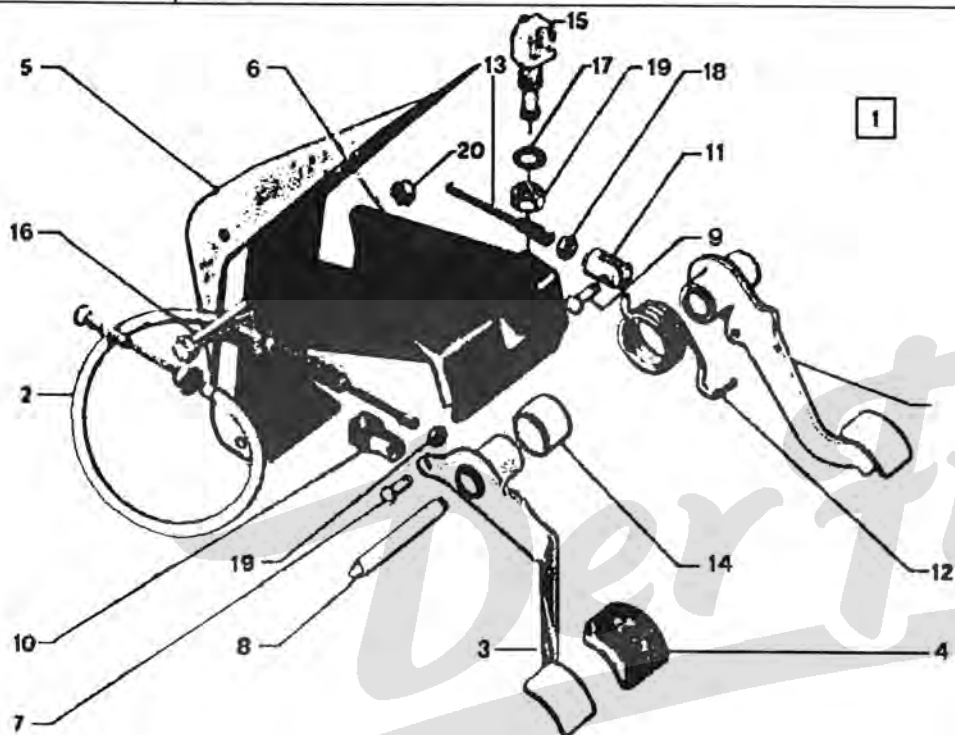

1117 04-3140-10  
Z3140100

► 1665

- LES PIECES NON REPEREES SONT N F P

01	95 566 670	01	SUPPORT PEDALE PEDALHALTER PEDAL BRACKET SOP PEDAL FRENO SUPPORTO
02	95 494 917	01 LON 699-FIL DIAM 2.5	CABLE DEBRAYAGE BET.-ZUG CONTROL CABLE CABLE EMBRAGUE C AVO COMANDO

03	AY 314 3 A	01	PEDALE KUPPLUNGSPEDAL CLUTCH PEDAL PEDAL EMBRAGUE PEDALE
04	95 575 913	02	1885 ► COIFFE PEDALE PEDALGUMMI PEDAL COVER FORRO PATIN PATTINO
05	AYB 453 352 A	02	SUPPORT RENVOI HALTER RETURN BRACKET SOPORTE REENVIO PATTINO
06	75 515 584	01	SUPPORT PEDALES PEDALWERKHALTER PEDAL BRACKET SOPORTE PEDALES SUPPORTO PEDALI
07	5 420 471	01 5X14	AXE DE PEDALE PEDALBOLZEN PEDAL SPINDLE EJE PEDAL PERNO PEDALE
08	5 410 804	01 DIAM 12 LON 80	-
09	5 417 536	01 DIAM 6-LON 20	AXE BOLZEN SPINDLE EJE PERNO
10	AM 314 55	01	CHAPE DE CABLE GABEL CABLE YOKE BRIDA DE CABLE PINZA CAVO
11	5 417 537	01	CHAPE DE TIGE KAPPE PUSHROD YOKE BRIDA VARILLA GIUNTO
12	AY 453 25	01 DIAM INT 30,5 LON 16	RESSORT FEDER RETURN SPRING MUELLE MOLLA

.../...

15/02/91  
1117 04-3140-10  
PAGE : 2  
C03 ↑

**PEDALIER - FREIN - DEBRAYAGE**  
**PEDALWERK - BREMSE - KUPPLUNG**  
**PEDAL GEAR - BRAKE - CLUTCH**  
**SOPORTE DE PEDALES EMBRAGUE**  
**PEDALIERA - FRENO - FRIZIONE**

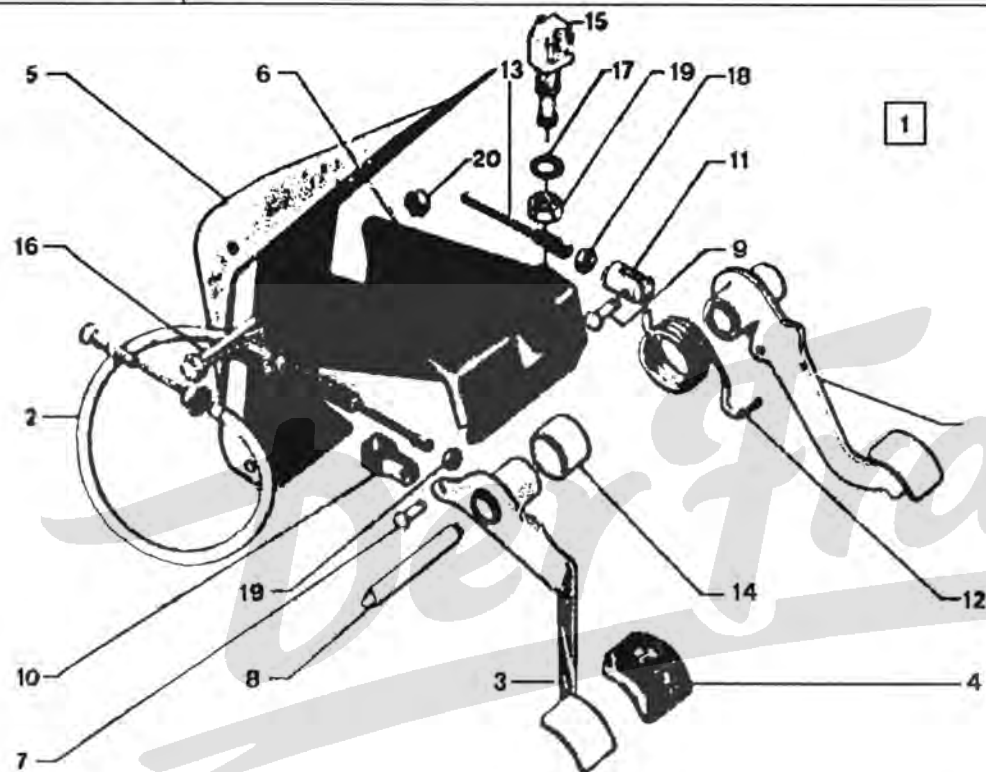

1117

1117

04-3140-10  
Z3140100

▶ 1665

13	5 438 258	01	DIAM 7X100-LON 88	TIGE DE POUSSSE STOESSELSTANGE PEDAL PUSHROD VARILLA EMPUJE ASTA PEDALE	52	95 494 918	01	LON 700-FIL DIAM 2.5 -CAD	CABLE DEBRAYAGE BET.-ZUG CONTROL CABLE CABLE EMBRAGUE CAVO COMANDO
14	AY 453 100	01	27X23X16	BAGUE DE RESSOR FEDERRING SPRING BUSH CASQUILLO BOCCOLA					

15	5 422 483	01	TORRIX	CONTACTEUR STOP BREMSSCHALTER CONTACT SWITCH INTERRUP PARE CONTATTORE STOP
16	23 836 019	02	TH 9-65	VIS TH SCHRAUBE CAPSCREW TORNILLO TH VITE
17	79 03 056 020	01	CR-DIAM 12,5X22	RONDELLE A DENT ZAHNSCHEIBE SPRING WASHER ARANDELA RONDELLA DENTAT
18	79 03 032 036	01	HE 7X1,00-5,5	ECROU MUTTER NUT TUERCA DADO
19	26 150 019 RP 26151069	02	HE 12X1,00	ECROU HEXAGONAL SECHSKANTMUTTER HEXAGONAL NUT TUERCA DADO ESAGONALE
20	79 03 032 247	02	DIAM 8X1,25	

**XT**

51	95 566 670	01	-(D) -(OK) -(A)	SUPPORT PEDALE PEDAL HALTER PEDAL BRACKET SOP.PEDAL FRENO SUPPORTO
----	------------	----	-----------------------	--

15/02/91  
1117 04-3140-11  
PAGE : 1  
C04 ↑

PEDALIER - FREIN - DEBRAYAGE  
PEDALWERK - BREMSE - KUPPLUNG  
PEDAL GEAR - BRAKE - CLUTCH  
SOPORTE DE PEDALES EMBRAGUE  
PEDALIERA - FRENO - FRIZIONE

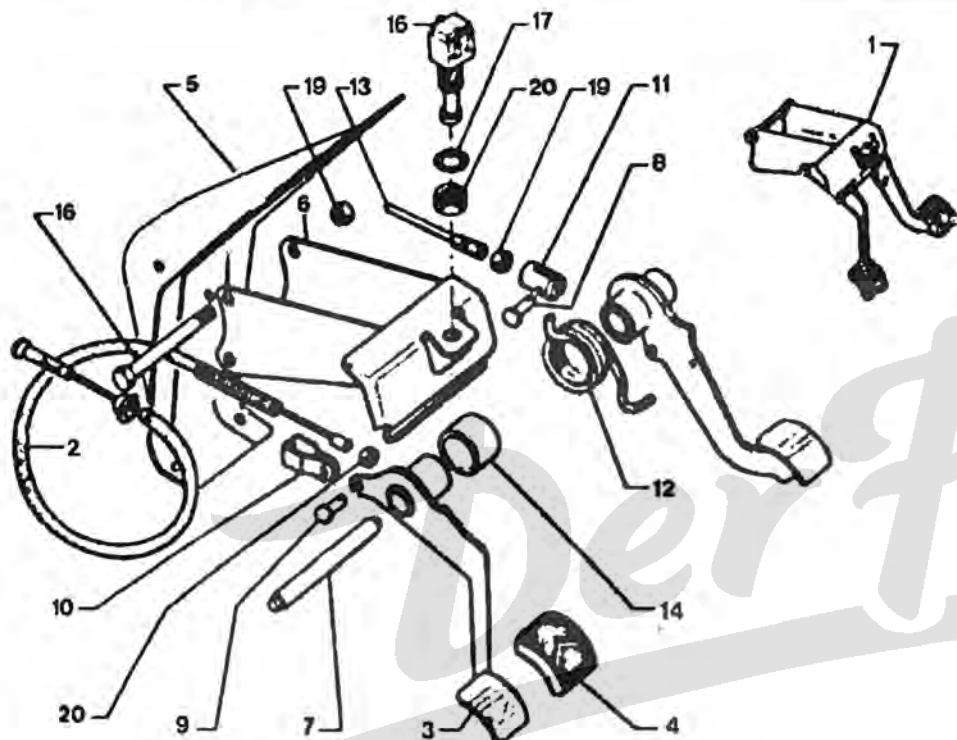

04 '91

Z3140110  
Z3140110

1666 ▶

- LES PIECES NON REPEREES SONT N F P

01	95 566 670	01	SUPPORT PEDALE PEDALHALTER PEDAL BRACKET SOP.PIEDAL FRENO SUPPORTO
02	95 494 917	01	LON 699-FIL DIAM 2.5 CABLE DEBRAYAGE BET.-ZUG CONTROL CABLE CABLE EMBRAGUE CAVO COMANDO

03	AY 314 3 A	01	PEDALE KUPPLUNGSPEDAL CLUTCH PEDAL PEDAL EMBRAGUE PEDALE
04	95 575 913	02	COIFFE PEDALE PEDALGUMMI PEDAL COVER FORRO PATIN PATTINO
05	AYB 453 352 A	02	SUPPORT RENVOI HALTER RETURN BRACKET SOPORTE REENVIO PATTINO
06	75 515 584	01	SUPPORT PEDALES PEDALWERKHALTER PEDAL BRACKET SOPORTE PEDALES SUPPORTO PEDALI
07	5 410 804	01	DIAM 12 LON 80 AXE DE PEDALE PEDALBOLZEN PEDAL SPINDLE EJE PEDAL PERNO PEDALE
08	5 417 536	01	DIAM 6-LON 20 AXE BOLZEN SPINDLE EJE PERNO
09	5 420 471	01	5X14 AXE DE PEDALE PEDALBOLZEN PEDAL SPINDLE EJE PEDAL PERNO PEDALE
10	AM 314 55	01	CHAPE DE CABLE GABEL CABLE YOKE BRIDA DE CABLE PINZA CAVO
11	5 417 537	01	CHAPE DE TIGE KAPPE PUSHROD YOKE BRIDA VARILLA GIUNTO

.../...

15/02/91  
1117 04-3140-11  
PAGE : 2  
C05 ↑

**PEDALIER - FREIN - DEBRAYAGE**  
**PEDALWERK - BREMSE - KUPPLUNG**  
**PEDAL GEAR - BRAKE - CLUTCH**  
**SOPORTE DE PEDALES EMBRAGUE**  
**PEDALIERA - FRENO - FRIZIONE**

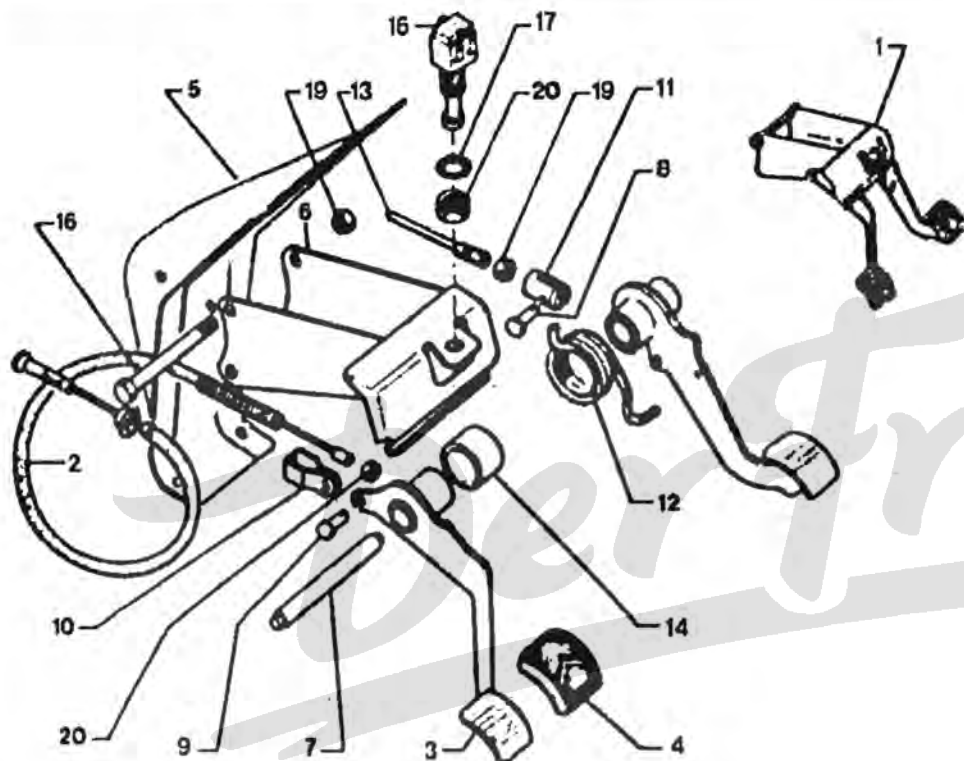

04 '91

Z3140110  
Z3140110

1666 ▶

12	AY 453 25	01	DIAM INT 30,5 LON 16	<b>RESSORT</b> FEDER RETURN SPRING MUELLE MOLLA
13	5 438 258	01	DIAM 7X100-LON 88	<b>TIGE DE POUSSEE</b> STOESSELSTANGE PEDAL PUSHROD VARILLA EMPUJE ASTA PEDALE

14	AY 453 100	01	27X23X16	<b>BAGUE DE RESSOR</b> FEDERRING SPRING BUSH CASQUILLO BOCCOLA
15	5 422 483	01	TORRIX	<b>CONTACTEUR STOP</b> BREMSSCHALTER CONTACT SWITCH INTERRUPT PARE CONTATTORE STOP
16	23 836 019	02	TH 9-65	<b>VIS TH</b> SCHRAUBE CAPSCREW TORNILLO TH VITE
17	79 03 056 020	01	CR-DIAM 12,5X22	<b>RONDELLE A DENT</b> ZAHNSCHEIBE SPRING WASHER ARANDELA RONDELLA DENTAT
18	79 03 032 036	01	HE 7X1,00-5,5	<b>ECROU</b> MUTTER NUT TUERCA DADO
19	25 413 019 RP 7903032247	02	HE 9X125 H 9	<b>ECROU HEXAGONAL</b> SECHSKANTMUTTER HEXAGONAL NUT TUERCA DADO ESAGONALE
20	79 03 032 247	02	DIAM 9X1,25	-
52	95 494 918	01	LON 700-FIL DIAM 2,5 -(XT)	<b>CABLE DEBRAYAGE</b> BET.-ZUG CONTROL CABLE CABLE EMBRAGUE CAVO COMANDO

**XT**

15/02/91  
1117 04-3733-10  
PAGE : 1  
C06 ↑

**TRANSMISSIONS A BILLES**  
**KUGELGELENKWELLEN**  
**BALL DRIVESHAFTS**  
**TRANSMISIONES DE BOLAS**  
**TRANSMISSIONI A SFERE**

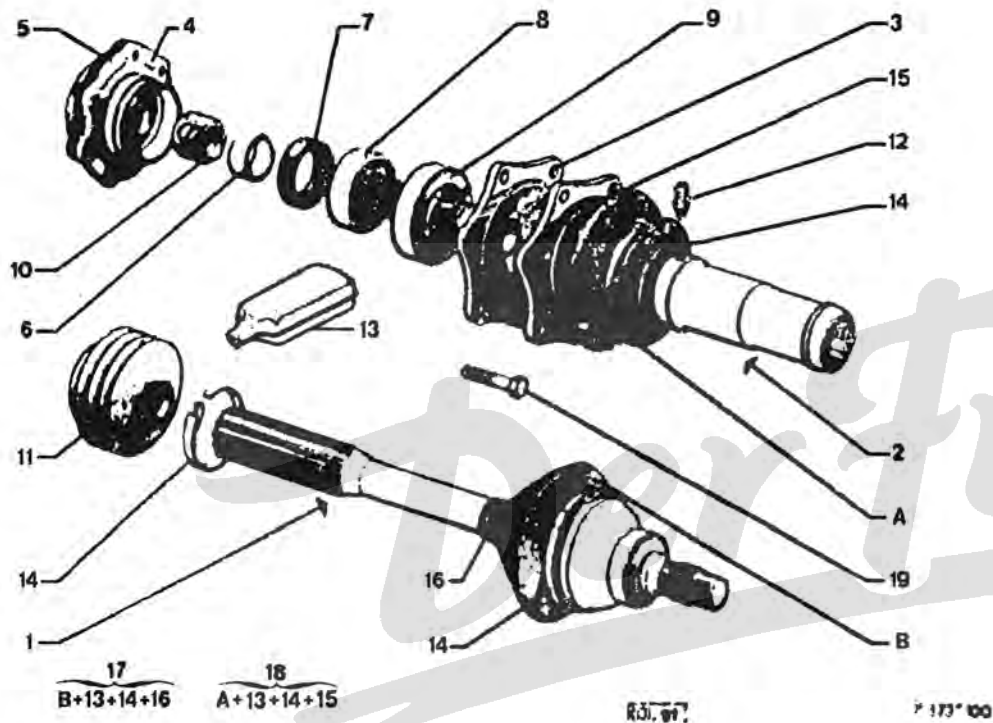

Z3733100

01	75 525 808	02	COTE ROUE REP 8GN10	TRANSMISSION NE ACHSWELLE NEU DRIVE-SHAFT NEW TRANSMISION NE TRASMISSIONE NE
02	75 516 490	02	COTE BV REP 8GN09	-
03	95 566 706	02	LON 156	ARBRE WELLE DRIVE SHAFT ARBOL TRANSMIS ALBERO

04	AM 371 3	01	G-	PALIER D'ARBRE WELLENLAGERUNG DR SHFT BEARING CAJA RODAMIENTO SUPPORTO ALBERO
	AM 371 3 A	01	D-	-
05	AM 331 86 A	02	6-DIAM 9	JOINT DE CARTER GEHAEUSEDICHTUN HOUSING GASKET JUNTA CARCASA GUARNIZIONE CAR
06	AM 371 92	02	25X31X11	ENTRETOISE ABSTANDSSTUECK SPACER JUEGO DISTANCIA DISTANZIALE
07	ZC 9612 644 U	02	31X42X8	BAGUE DE PALIER LAGERKUELSE BEARING BUSH CASQUILLO BOCCOLA SUPPORT
08	79 03 090 190	02	DIAM 25X52 -15	ROULEMENT LAGER CRKSHAFT BEARG RODAMIENTO CUSCINETTO
09	75 527 579	02	DIAM 81X1,50	VIS GLOBIQUE KUGELSCHRAUBE STEERING SCREW TORNILLO GLOBOI VITE CONICA
10	95 498 712	02	DIAM 25X1,50	ECROU MUTTER NUT TUERCA DADO
11	A 372 88 A	02		GÂINE SCHUTZHUELLE PROTECT SHEATH VAINA GUAINA
12	95 602 714	02	DIAM 7X1,00	GRAISSEUR SCHMIERNIPPEL TRANSMISS OILER ENGRASADOR INGRASSATORE

.../...

15/02/91  
1117 04-3733-10  
PAGE : 2  
C07 ↑

**TRANSMISSIONS A BILLES**  
**KUGELGELENKWELLEN**  
**BALL DRIVESHAFTS**  
**TRANSMISIONES DE BOLAS**  
**TRANSMISSIONI A SFERE**

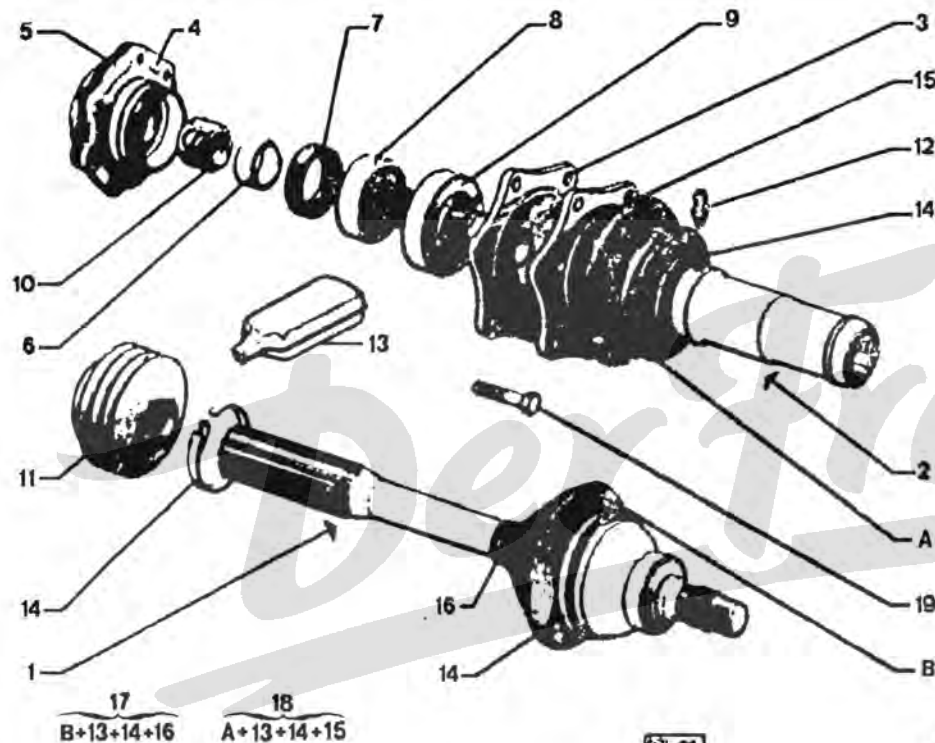

Z3733100

15	79 03 083 156	04	LON 800	COLLIER SCHELLE BOOT CLAMP ABRAZADERA COLLARE
16	79 03 083 153	02	LON 240	-
17	95 532 941	02	ENS *PAM* COTE ROUE	ENS PROTECTION ACHSMANSCHETTE BOOT PROTECTING CONJ. PROTECCI. INS. PROTEZIONE
18	95 532 947	02	ENS *PAM* COTE BV	-
19	75 527 610	12	DIAM 9X1.25X26.7	VIS DE CARDAN SCHRAUBE SCREW UNIVER JT TORNILLO CARDAN VITE

13	95 615 129	99	80 GR9	GRAISSE FETT GREASE GRASA GRASSO
14	79 03 083 250	04	LON 580 LAR 5	COLLIER METAL METALLSCHELLE METALLIC CLAMP ABRAZADERA COLLARE METALL.



15/02/91  
1117 04-4512-10  
PAGE : 1  
C08 ↑

**FREINS AVANT - ETRIERS ET DISQUES**  
VORDERE BREMSEN - GABELN UND SCHEIBEN  
FRONT BRAKES - CALIPERS AND DISCS  
FRENOS DELANTEROS - CALIPERES Y DISCOS  
FRENI ANTERIORI - PINZE E DISCHI

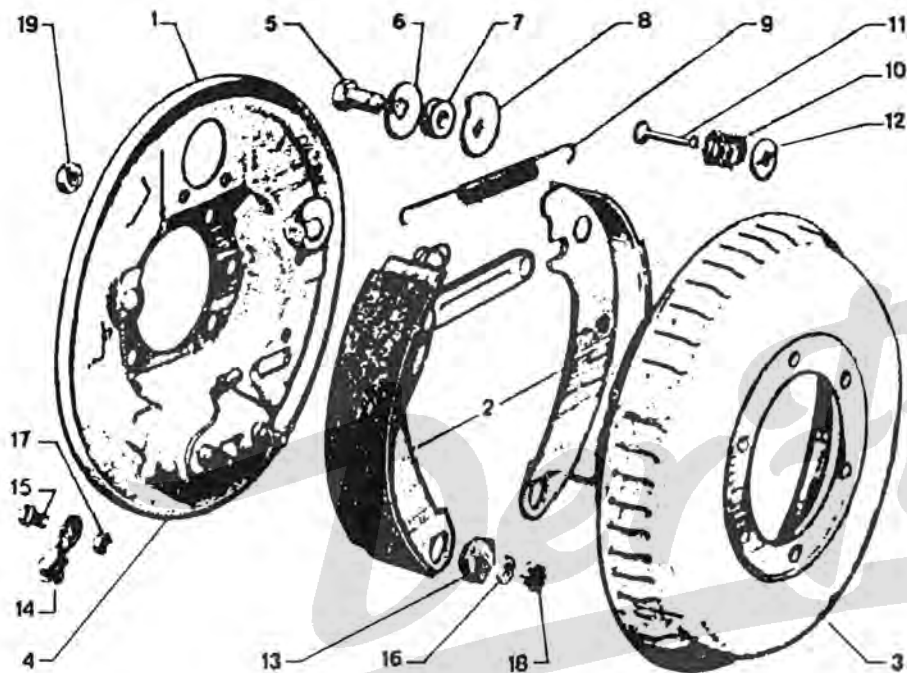

1114

4-451-10  
Z4512100

► 1665

01	5 426 248	01	G.	DISQUE SCHEIBE BRAKE DISC DISCO DE FRENO DISCO
	5 426 249	01	D.	-
02	AZ 451 016 A	01	AV	JEU 4 SEGMENTS SATZ 4 BACKEN SET 4 BRAK SHOE JUEGO 4 ZAPATAS SERIE 4 GANASCE

03	AY 451 6 A	02	AV-DIAM INT 200-6	TAMBOUR FREIN BREMSTROMMEL BRAKE DRUM TAMBOR TAMBURO
04	A 451 2	04	AR-DIAM 7X1,00-28	AXE DE LOQUET RIEGELBOLZEN CAM PIN EJE LEVA ZAPATA PERNO CHIAVIST.
05	AZ 451 17	04	TH9	-
06	26 190 519	08	DIAM9,5X27	RONDELLE SCHEIBE WASHER ARANDELA RONDELLA
07	A 451 75	04	DIAM 9-H 7	ENTRETOISE ABSTANDSSTUECK SPACER JUEGO DISTANCIA DISTANZIALE
08	A 451 16	04	AR	CAME DE REGLAGE NOCKEN ADJUSTMENT CAM LEVA DE REGLAJE CAMMA
09	A 451 14 B	02	LON 131	RESSORT SEGMENT B-BACKENFEDER SHOE SPRING MUELLE ZAPATA MOLLA CEPPO
10	A 451 85	04	AR-DIAM 18	-
11	A 451 83	04	AR LON 35	TIGE DE RESSORT STANGE SPRING ROD VARILLA RESORTE ASTA DI MOLLA
12	ZC 9438 157 U	04	INT19	COUPELLE TELLER CENTERING CUP COPELA CENTRAJE SCODELLINO
13	A 451 15 B	04	H 72	EXCENTRIQUE EXZENTER ECCENTRIC EXCENTRICA ECCENTRICO

.../...

15/02/91  
1117 04-4512-10  
PAGE : 2  
C09 ↑

**FREINS AVANT - ETRIERS ET DISQUES**  
**VORDERE BREMSEN - GABELN UND SCHEIBEN**  
**FRONT BRAKES - CALIPERS AND DISCS**  
**FRENOS DELANTEROS - CALIPERES Y DISCOS**  
**FRENI ANTERIORI - PINZE E DISCHI**

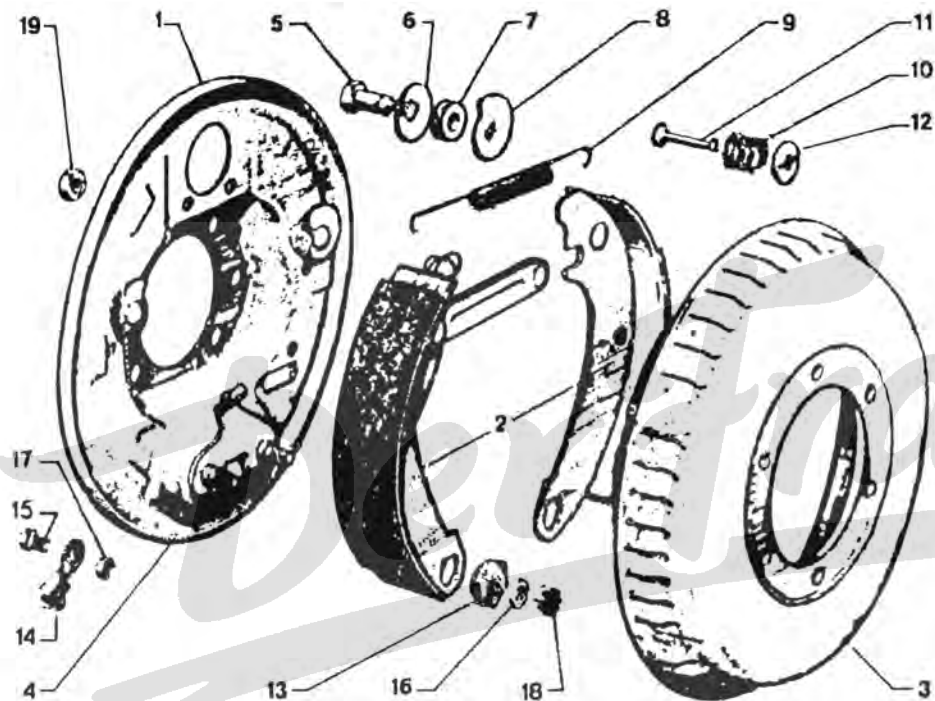

1114

4\_451\_10  
Z4512100

▶ 1665

14	A 454 18	01 G-	ARRET DE GAINÉ HUELLENANSCHLAG SHEATH STOP ARRESTO GUAINA ECCENTRICO
	A 454 18 A	01 D-	.
15	79 03 201 020	02 DIAM 8X1.00-12	▶ 05/81 VIS TH SCHRAUBE CAPSCREW TORNILLO TH VITE

16	79 03 053 390	08 DIAM 7X14X1,5	RONDELLE PLATE FLACHSCHEIBE PLAIN WASHER ARANDELA PLANA RONDELLA PIATTA
17	79 03 032 070	02 H 6X1.00	ECROU HEXAGONAL SECHSKANTMUTTER HEXAGONAL NUT TUERCA DADO ESAGONALE
18	ZD 9249 400 U	04 DIAM 7X1.00	ECROU CRENELE KRONENMUTTER CASTLE NUT TUERCA ALMENADA DADO A SFINA
19	ZC 9615 030 U	12 DIAM 9X1,25	ECROU HEXAGONAL SECHSKANTMUTTER HEXAGONAL NUT TUERCA DADO ESAGONALE

10/2/91  
17 04-4512-11  
AGE : 1  
0 ↑

**FREINS AVANT - ETRIERS ET DISQUES**  
**VORDERE BREMSEN - GABELN UND SCHEIBEN**  
**FRONT BRAKES - CALIPERS AND DISCS**  
**FRENOS DELANTEROS - CALIPERES Y DISCOS**  
**FRENI ANTERIORI - PINZE E DISCHI**

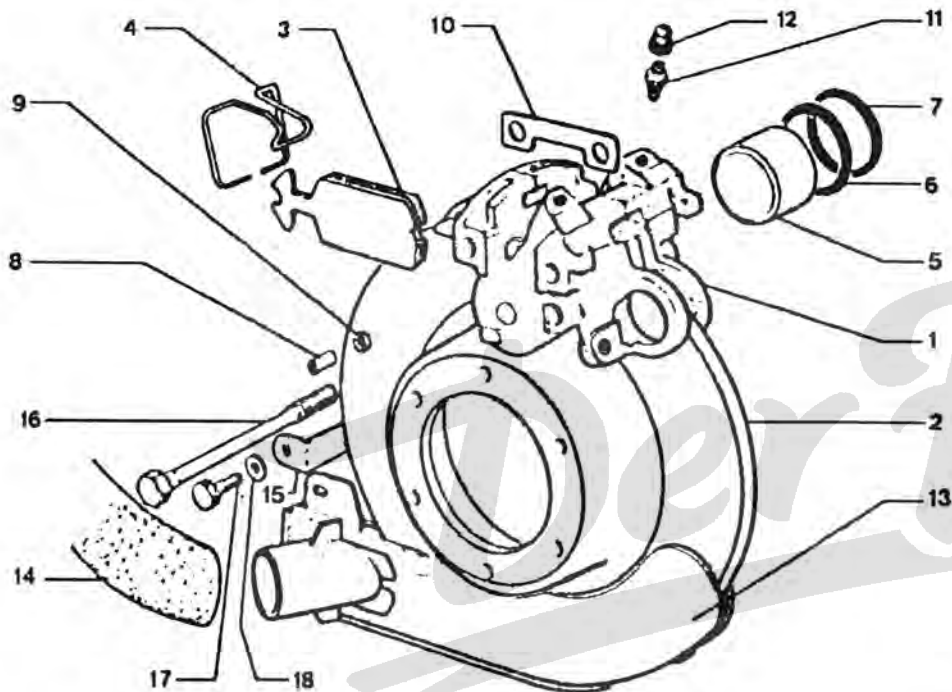

4-451-11  
Z4512110

1666 ▶

ATTENTION: "MIN" (MINERAL) REPERE VERT OU BANC

95 535 826	02 AV	ETRIER DE FREIN BREMSSATTEL BRAKE CALIPER CALIPER FRENO PINZA DEL FRENO
95 599 322	02 AV-DIAM 244	DISQUE SCHEIBE BRAKE DISC DISCO DE FRENO DISCO

03	75 516 219	01 AV - 1 POS	JEU 4 PLAQUETT. SATZ 4 BELAEGE SET 4 BRAKE PAD JUEGO 4 PASTIL SERIE 4 PIASTRE
	75 516 220	01 AV - 2 POS	-
04	5 420 183	02 AV	RESSORT FEDER BRAK PAD SPRING MUELLE MOLLA
05	GX 25 266 01A	04 AV-DIAM 42-H 27	PISTON D'ETRIER SATELKOLBEN CALIPER PISTON PISTON CALIPER PISTONCINO FREN
06	5 403 207	04 42X47X2,5	JOINT DE PISTON KOLBENDICHTUNG PISTON SEAL JUNTA DE PISTON GURNIZ.PISTONE
07	5 403 208	04 40,8X47X2,8	
08	5 405 104	02	GOUILLE ZENTRIERSTIFT CENTRING PIN PASADOR COPPIGLIA
09	95 587 148	02 DIAM 7,2 X11X1,9	JOINT D'ETRIER SATELDICHTUNG CALIPER SEAL JUNTA CALIPER GURNIZ.PINZA
10	5 420 184	99 AV	CALE D'ETRIER UNTERLAGE CALIPER SHIM CALA DE CALIPER SPESSORE PINZA
11	95 578 349	02 DIAM 10X1,00-22 RMP 75485818 DEO-7941401043	VIS DE PURGE ENTLUEFTSCHRAUB DRAIN SCREW TORNILLO PURGA VITE SPURGO
	95 578 352	02 TH 8X25 RMP 75468367 DEO-7941401043	-

.../...

15/02/91  
1117 04-4512-11  
PAGE :2  
C11 ↑

**FREINS AVANT - ETRIERS ET DISQUES**  
**VORDERE BREMSEN - GABELN UND SCHEIBEN**  
**FRONT BRAKES - CALIPERS AND DISCS**  
**FRENOS DELANTEROS - CALIPERES Y DISCOS**  
**FRENI ANTERIORI - PINZE E DISCHI**

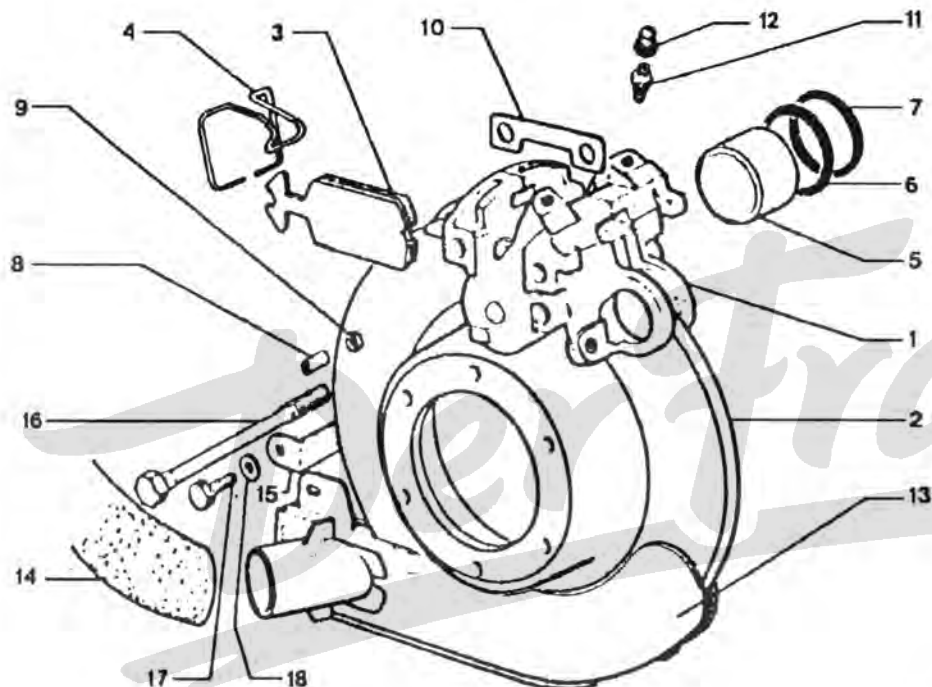

1114

4.451.11  
Z4512110

1666 ▶

12	75 434 307	02		CAPUCHON PURGE KAPPE F ABLASS BLEED SCREW CAP CAPUCHON PURGA CUFFIA SPURGO
13	AM 452 80	01	G-	DEFLECTEUR LUFTABWEISER BRAKE AIR DEFCT DEFLECTOR DEFLETTORE ARIA
	AM 452 81	01	D-	.

14	95 547 230	02	DIAM INT 40-LON 230	MANCHE STIEL HAMMER HANDLE MANGO MANICO
15	AM 452 96	02	1 DIAM 10-DIAM 5X75	PATTE HALTELASCHE SUPPORT LUG SOPORTE STAFFA
16	5 420 264	04	AV-DIAM 10X1,50-139	VIS FIX ETRIER SCHRAUBE CALIPER SCREW TORNILLO VITE FISSAGGIO
17	79 03 201 130	02	DIAM 5 X 0,80 - 16	VIS TH SCHRAUBE CAPSCREW TORNILLO TH VITE
18	95 623 757	02	DIAM 5X16	RONDELLE A DENT ZAHNSCHEIBE SPRING WASHER ARANDELA RONDELLA DENTAT

55	95 653 061	01	-SANS AMIANTE 4437 ▶	<b>XT</b>  JEU 4 PLAQUETT. SATZ 4 BELAEGE SET 4 BRAKE PAD JUEGO 4 PASTIL. SERIE 4 PIASTRE
----	------------	----	----------------------	---

15/02/91  
1117 04-4515-20  
PAGE : 1  
C12 ↑

**FREIN ARRIERE**  
**HINTERE BREMSE**  
**REAR BRAKE**  
**FRENOS TRASERO**  
**FRENI POSTERIORI**

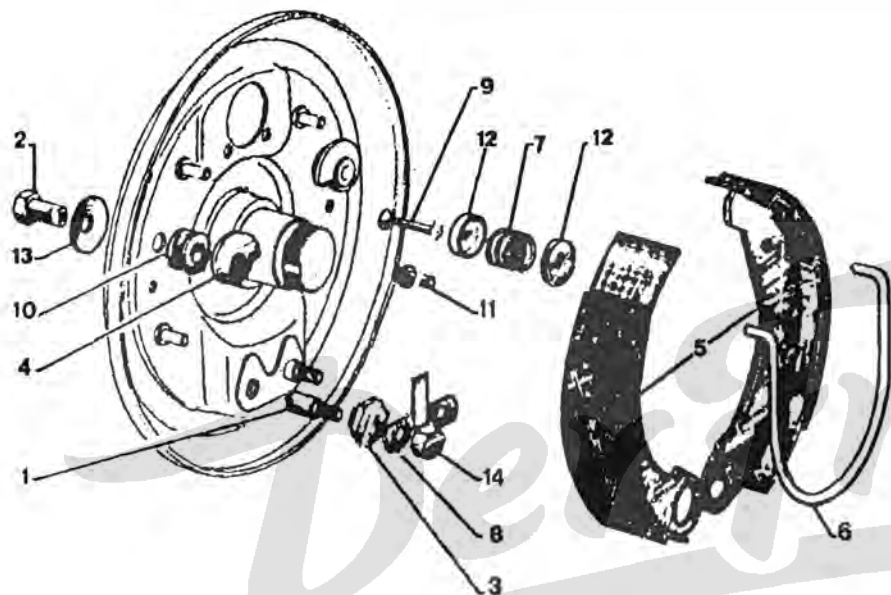

1117



04\_4515.20

Z4515200

01	AZ 451 202 A	04 AR-DIAM 7X1,00-28	AXE DE LOQUET RIEGELBOLZEN CAM PIN EJE LEVA ZAPATA PERIIO CHIAVIST.
02	A 451 3	04 TH DIAM 9	-
03	A 451 15 C	04 H 6,7	EXCENTRIQUE EXZENTER ECCENTRIC ECCENTRICA ECCENTRICO

04	A 451 16	04 AR	CAME DE REGLAGE NOCKEN ADJUSTMENT CAM LEVA DE REGLAJE CAMMA
05	AM 451 018 A	01 AR	JEU 4 SEGMENTS SATZ 4 BACKEN SET 4 BRAK SHOE JUEGO 4 ZAPATAS SERIE 4 GANASCE
06	AM 451 21 A	02 DIAM 5,5	RESSORT RUCKZUGFEDER RETURN SPRING MUELLE MOLLA RICHIAMO
07	A 451 85	04 AR-DIAM 18	RESSORT SEGMENT B-BACKENFEDER SHOE SPRING MUELLE ZAPATA MOLLA CEPPO
08	AZ 451 65	02 2 DIAM 8	ARRETOIR ARRETIERUNG RETAINER REten ARRESTO
09	A 451 83	04 ARLON35	TIGE DE RESSORT STANGE SPRING ROD VARILLA RESORTE ASTA DI MOLLA
10	A 451 86	04 DIAM 9X10	ENTRETOISE ABSTANDSSTUECK SPACER JUEGO DISTANCIA Distanziale
11	A 451 87	08 LON 24	APPUI SEGMENT HALTER SHOE SUPPORT APOYO ZAPATA APPOGGIO
12	ZC 9438 157 U	04 INT19	COUPELLE TELLER CENTERING CUP COPELA CENTRAJE SCODELLINO

.../...

15/02/91  
 1117 04-4515-20  
 PAGE :2  
 C13 ↑

**FREIN ARRIERE**  
**HINTERE BREMSE**  
**REAR BRAKE**  
**FRENOS TRASERO**  
**FRENI POSTERIORI**

15

95 618 235

01

ENS "PAM" ▶ 1665

ENS SEGMENT+CYL  
 SATZ RINGE+ZYL.  
 REAR BRAKE ASSY  
 CONJ.SEG. + CYL  
 INS SEGM. + CIL.

95 618 237

01

1666 ▶

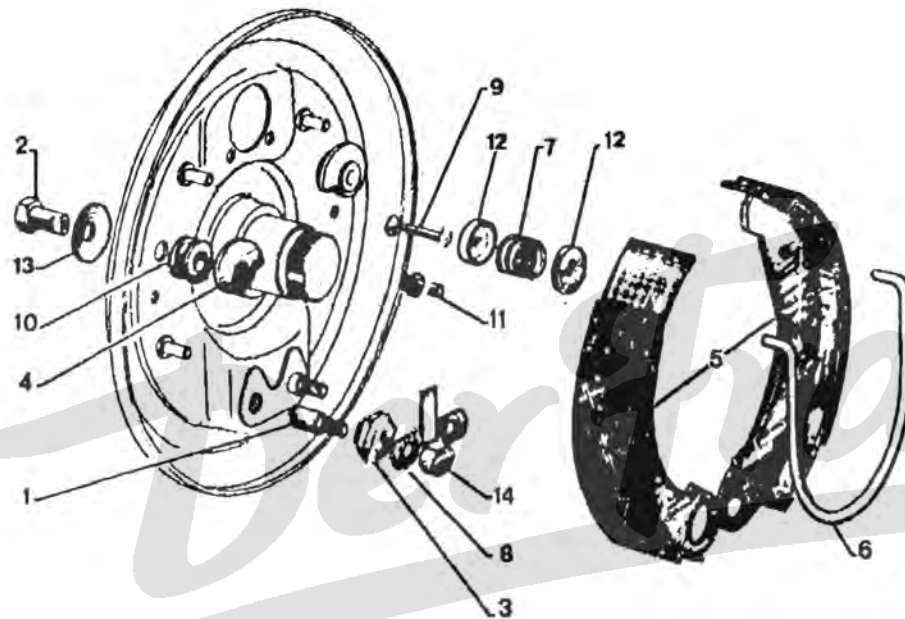

1117



04\_4515\_20

Z4515200

13

26 190 519

08

DIAM9,5X27

RONDELLE  
 SCHEIBE  
 WASHER  
 ARANDELA  
 RONDELLA

14

79 03 032 036

04

HE 7X1,00-5,5

ECROU  
 MUTTER  
 NUT  
 TUERCA  
 DADO

15/02/91  
1117 04-4530-10  
PAGE : 1  
C14 ↑

**CANALISATIONS DE FREIN**  
BREMSLEITUNGEN  
BRAKE PIPINGS  
CANALIZACIONES DE FRENO  
CANALIZZAZIONI FRENO

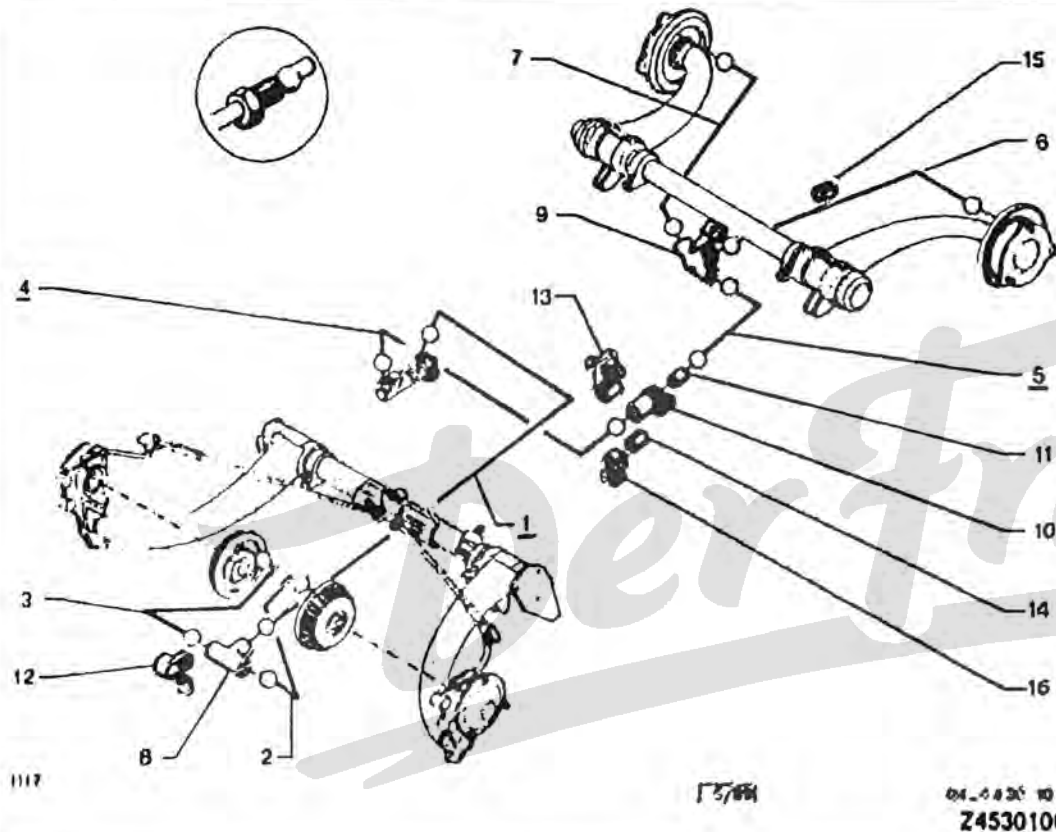

► 1665

LIQUIDE SYNTHETIQUE EXCLUSIVEMENT

01	5 447 525	01	DIAM 3,5	TUBE ROHR HYDRAULIC TUBE TUBO HIDRAULICO TUBO IDRAULICO
02	95 641 001	01	G- G-AV	-
03	AY 453 333 A	01	D- AV	-
04	5 472 299	01	AR	-
05	AM 453 33 D	01		-

06	5 421 919	01	G-AR RMP75531949	TUYAU DE FREIN BREMSLEITUNG BRAKE PIPE TUBO DE FRENO TUBO FRENO
07	5 421 922	01	D-AR RMP75531950	-
08	5 438 353	01	AV 3 DIAM 8X1,25	RACCORD 3 VOIES 3WEGEVERBINDUNG PIPE 3WAY UNION RACOR 3 VIAS RACCORDO 3 VIE
09	AM 453 134	01	AR	RACCORD VERBINDUNG BRAK HOSE UNION RACOR TUBERIA RACCORDO
10	96 995 250	01	AR	-
11	21 589 009	99	4X6,2X9,5 CAOUTCHOUC	GARNITURE BESCHLAEGE PIPE LINING GUARNECIDO RIVESTIMENTO
12	AY 453 175	99		PATTE HALTELASCHE SUPPORT LUG SOPORTE STAFFA
13	26 199 449	01	1 DIAM 3.5	SUPPORT HALTER LINE BRACKET SOPORTE SUPPORTO
14	5 411 956	06	4X9-15	GAINE HUELLE PROTECT SLEEVE VAINA GUAINA
15	5 413 895	02	9X21X30	BAGUE FIX HALTERING FIXING RING CASQUILLO BOCCOLA

.../...

15/02/91  
1117 04-4530-10  
PAGE : 2  
C15 →

**CANALISATIONS DE FREIN**  
**BREMSLEITUNGEN**  
**BRAKE PIPINGS**  
**CANALIZACIONES DE FRENO**  
**CANALIZZAZIONI FRENO**

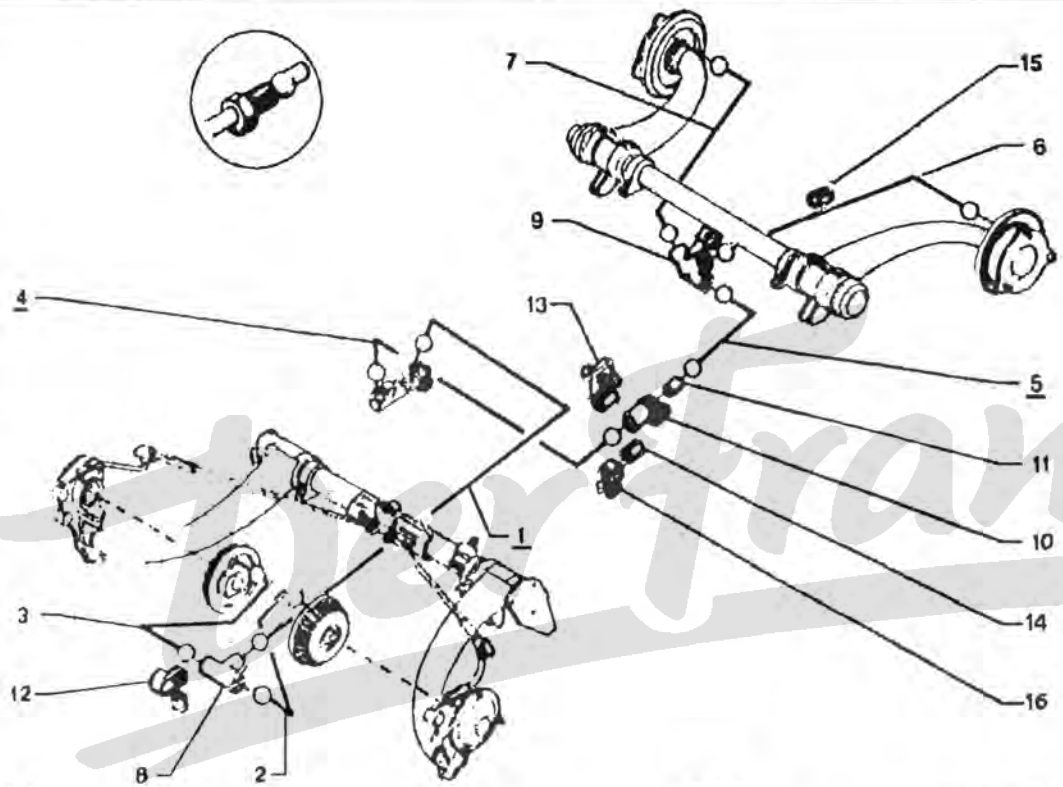

1117

15/04

04-4530-10  
Z4530100

▶ 1665

16	AM 174 221 A	06	1 DIAM 3,5-1 DIAM 6	AGRAFE KLAMMER CLIP GRAPA AGRAFE
51	75 522 848 NFP	01	-CAD  <b>XT</b>	TUBE ROHR HYDRAULIC TUBE TUBO HIDRAULICO TUBO IDRAULICO

54	75 522 849	01	-CAD	TUBE ROHR HYDRAULIC TUBE TUBO HIDRAULICO TUBO IDRAULICO
55	AM 453 333 A	01	-CAD	-
	26 199 999	01	4 DIAM -CAD	SUPPORT HALTER LINE BRACKET SOPORTE SUPPORTO



**CANALISATIONS DE FREIN**  
 BREMSLEITUNGEN  
 BRAKE PIPINGS  
 CANALIZACIONES DE FRENO  
 CANALIZZAZIONI FRENO

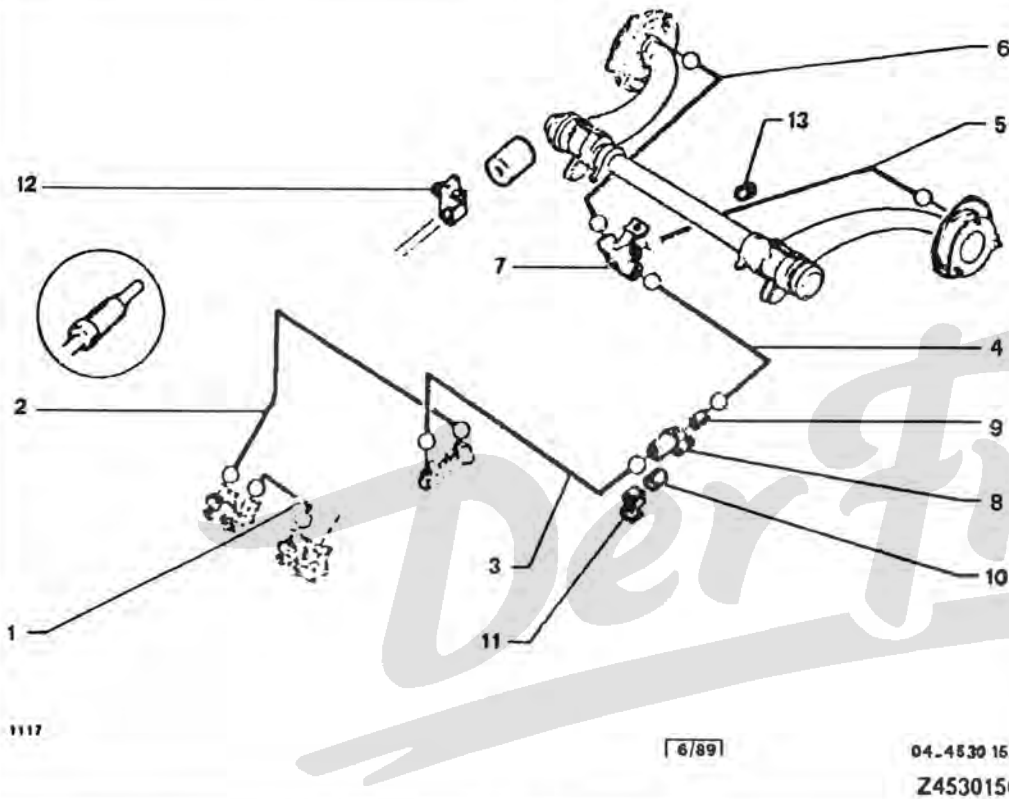

1666 ▶

\* LIQUIDE MINERAL EXCLUSIVEMENT NOTA : LES REPERES 3-4 ET 8 EN PR  
 CORRESPONDENT A UN TUBE  
 UNIQUE EN SERIE P

01	75 529 700	01	DIAM 3,5	TUBE ROHR HYDRAULIC TUBE TUBO HIDRAULICO TUBO IDRAULICO
02	75 529 692	01	LON 1600	-
03	AY 453 342 A	01		-
04	AM 453 33 D	01		-

05	5 421 919	01	G-AR RMP 75531949	TUYAU DE FREIN BREMSLEITUNG BRAKE PIPE TUBO DE FRENO TUBO FRENI
06	5 421 922	01	D-AR RMP 75531950	-
07	AM 453 134	01	AR	RACCORD VERBINDUNG BRAK HOSE UNION RACCR TUBERIA RACCORDO
08	96 995 250	01	AR	-
09	21 888 009 RP 96085785	99	3,5X5,6-9,5	GARNITURE BESCHLAEGE PIPE LINING GUARNECIDO RIVESTIMENTO
10	5 411 956	08	4X9-15	GAINÉ HUELLE PROTECT SLEEVE VAINA GUAINA
11	AM 174 221 A	06	1 DIAM 3,5-1 DIAM 6	AGRAFE KLAMMER CLIP GRAPA AGRAFE
12	26 199 449	01	1 DIAM 3,5	SUPPORT HALTER LINE BRACKET SOPORTE SUPPORTO
13	5 413 895	02	9X21X30	BAGUE FIX HALTERING FIXING RING CASQUILLO BOCCOLA
52	75 529 694	01	LON 1600 -(D) -(DK) -(A)	<b>XT</b> TUBE ROHR HYDRAULIC TUBE TUBO HIDRAULICO TUBO IDRAULICO

15/02/91  
 1117 04-4530-15  
 PAGE : 2  
 D14 ↓

**CANALISATIONS DE FREIN**  
 BREMSLEITUNGEN  
 BRAKE PIPINGS  
 CANALIZACIONES DE FRENO  
 CANALIZZAZIONI FRENO

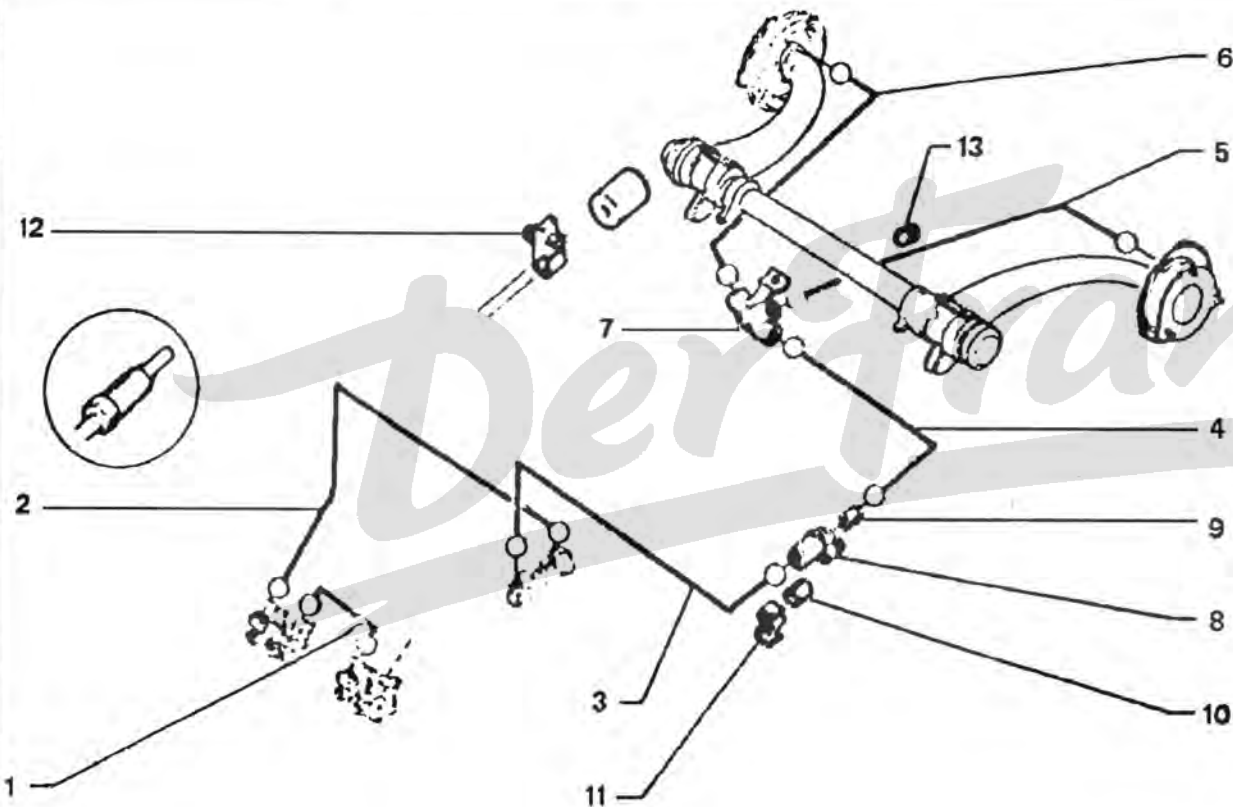

1117

6/89

04-4530 15  
 Z4530150

1666 ▶

52	75 529 696	01	LON 1350 -CAD	TUBE ROHR HYDRAULIC TUBE TUBO HIDRAULICO TUBO IDRAULICO
53	5 444 063	01	-(D) -(DK) -(A)	-
	5 472 299	01	AR -(B) -(NL)	-
	75 522 849	01	-CAD	-
54	AM 453 333 A	01	-CAD	-

15/02/81  
1117 04-4535-10  
PAGE : 1  
D13 ↓

**MAITRE CYLINDRE TANDEM - RESERVOIR**  
TANDEM-HAUPTBREMSZYLINDER-BEHAELTER  
TANDEM MASTER CYLINDER TANK  
BOMBA PRINCIPAL TANDEM - DEPOSITO  
CILINDRO MAESTRO TANDEM - SERBATOIO

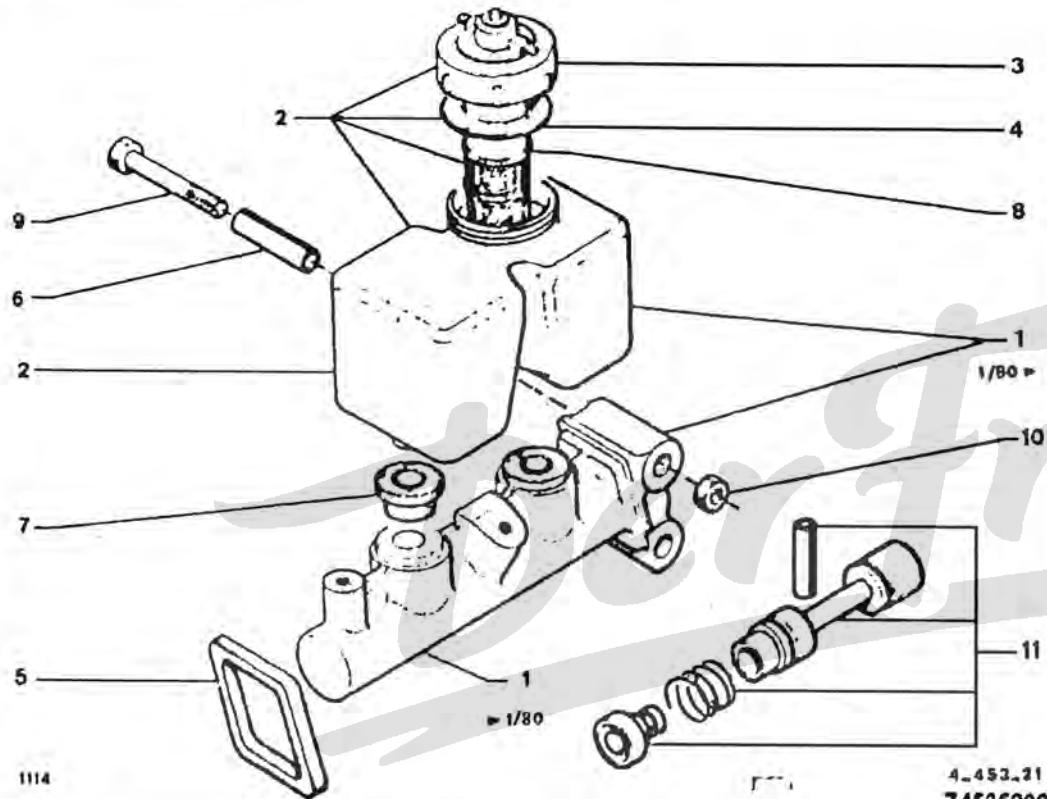

▶ 1665

LIQUIDE SYNTHETIQUE EXCLUSIVEMENT NOTA : POUR LES VEHICULES AVANT  
LE 02-1980 VOIR NT 80207A

01	95 535 855	01	ENS AVEC FILTRE	MAITRE CYLINDRE HAUPTZYLINDER MASTER CYLINDER CILINDRO MAEST. POMPA FRENI
02	95 554 585	01	AVEC BOUCHON + JOINT	RESERVOIR BEHAELTER BRAKE RESERVOIR DEPOSITO SERBATOIO

03	75 491 743	01	"NIVOCODE"	BOUCHON STOPFEN RESERVOIR CAP TAPON DEPOSITO TAPPO
04	75 486 303	02	DIAM 28,5X46 - E 1,5	JOINT DICHTUNG RESERVOIR SEAL JUNTA GUARNIZIONE
05	AM 453 211	01	44X59	-
06	AY 453 205	02	DIAM INT 9	ENTRETOISE ABSTANDSSTUECK SPACER JUEGO DISTANCIA DISTANZIALE
07	95 538 713	02		JOINT DICHTUNG RESERVOIR SEAL JUNTA GUARNIZIONE
08	95 493 138	01	DIAM 31,5 H 63	FILTRE FILTER BRAKE FILTER FILTRO FILTRO
09	23 836 019	02	TH 9-65	VIS TH SCHRAUBE CAPSCREW TORNILLO TH VITE
10	79 03 032 247	02	DIAM 9X1,25	ECROU HEXAGONAL. SECHSKANTMUTTER HEXAGONAL NUT TUERCA DADO ESAGONALE
11	75 511 661	01	▶ 01/80	NEC MAITRE CYL REP-SATZ MASTER-CYL KIT JUEGO MAEST-CYL NECESSARIO
	95 562 402	01	02/80 ▶	-

15/02/91  
1117 04-4535-20  
PAGE : 1  
D12 ↓

**MAITRE CYLINDRE TANDEM - RESERVOIR**  
TANDEM-HAUPTBREMSZCYLINDER BEHAELTER  
TANDEM MASTER CYLINDER- TANK  
BOMBA PRINCIPAL TANDEM - DEPOSITO  
CILINDRO MAESTRO TANDEM - SERBATOIO

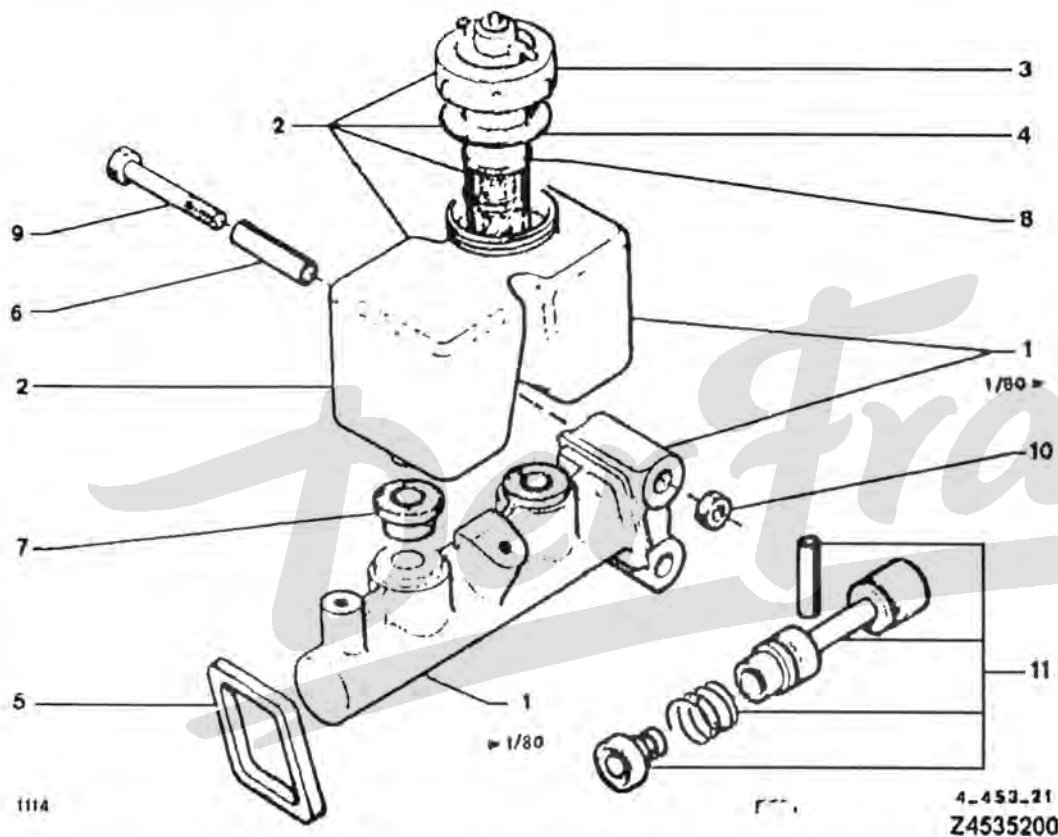

1666 ▶

LIQUIDE MINERAL EXCLUSIVEMENT

01	95 588 595	01 AVEC RESERVOIR + JOINT	MAITRE CYLINDRE HAUPTZYLINDER MASTER CYLINDER CILINDRO MAEST. POMPA FRENI
02	95 588 594	01 AVEC FILTRE	RESERVOIR BEHAELTER BRAKE RESERVOIR DEPOSITO SERBATOIO

03	75 491 744	01 "NIVOCODE"	BOUCHON STOPFEN RESERVOIR CAP TAPON DEPOSITO TAPPO
04	75 486 303	01 DIAM 28,5X46 - E 1,5	JOINT DICHTUNG RESERVOIR SEAL JUNTA GUARNIZIONE
05	AM 453 211	01 44X59	-
06	AY 453 205	02 DIAM INT 9	ENTRETOISE ABSTANDSSTUECK SPACER JUEGO DISTANCIA DISTANZIALE
07	95 538 713	02	JOINT DICHTUNG RESERVOIR SEAL JUNTA GUARNIZIONE
08	95 493 138	01 DIAM 31,5 H 63	FILTRE FILTER BRAKE FILTER FILTRO FILTRO
09	23 836 019	02 TH 9-65	VIS TH SCHRAUBE CAPSCREW TORNILLO TH VITE
10	79 03 032 247	02 DIAM 9X1,25	ECROU HEXAGONAL. SECHSKANTMUTTER HEXAGONAL NUT TUERCA DADO ESAGONALE
11	95 552 403	01	NEC MAITRE CYL REP-SATZ MASTER-CYL KIT JUEGO MAEST-CYL NECESSARIO

5/02/91  
 1117 04-4536-10  
 PAGE : 1  
 011 ↓

**CYLINDRE DE ROUE AVANT**  
**RADZYLINDER - VORN**  
**WHEEL CYLINDERS - FRONT**  
**BOMBINES DE RUEDAS - DELANTEROS**  
**CILINDRETTI RUOTE - ANTERIORE**

03	79 41 401 043	02	CAPUCHON PURGE KAPPE F ABLASS BLEED SCREW CAP CAPUCHON PURGA CUFFIA SPURGO
04	95 585 487	02	REDUIT
	85 554 041 RP 95585487	02	MONTAGE SPECIAL *FEG* -
			NEC DE CYLINDRE REP-SATZ ZYLIND BRAKE CYL KIT JUEGO REPAR NECESSARIO

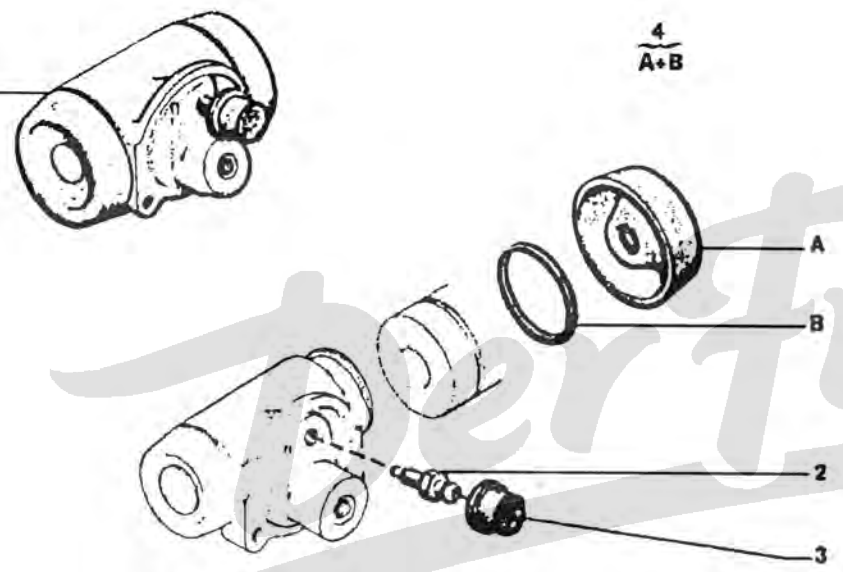

1114 [00.83] 4.493.30  
 Z4536100

▶ 1665

LIQUIDE SYNTHETIQUE EXCLUSIVEMENT

75 492 434	02	DIAM 3,5	CYLINDRE ROUE RADBR.ZYLINDER WHEEL CYLINDER CILINDRO FRENO CILINDRO
95 578 347	02	RMP DEO-1 7941401043	VIS DE PURGE ENTL-SCHRAUBE DRAIN SCREW TORNILLO PURGA VITE DI SPURGO

15/02/91  
 1117 04-4537-10  
 PAGE : 1  
 D10 ↓

**CYLINDRE DE ROUE ARRIERE**  
 HINTERE RADZYLINDER  
 REAR WHEEL CYLINDER  
 BOMBIN DE RUEDA TRAS.  
 CILINDRETTO RUOTA POST

03 95 578 347 02 RMP DEO 1 7941401043

04 79 41 401 043 02

05 5 506 709 02 REDUIT

**VIS DE PURGE**  
 ENTL.-SCHRAUBE  
 DRAIN SCREW  
 TORNILLO PURGA  
 VITE DI SPURGO

**CAPUCHON PURGE**  
 KAPPE F ABLASS  
 BLEED SCREW CAP  
 CAPUCHON PURGA  
 CUFFIA SPURGO

**NEC DE CYLINDRE**  
 REP-SATZ ZYLIND  
 BRAKE CYL KIT  
 JUEGO REPAR  
 NECESSARIO

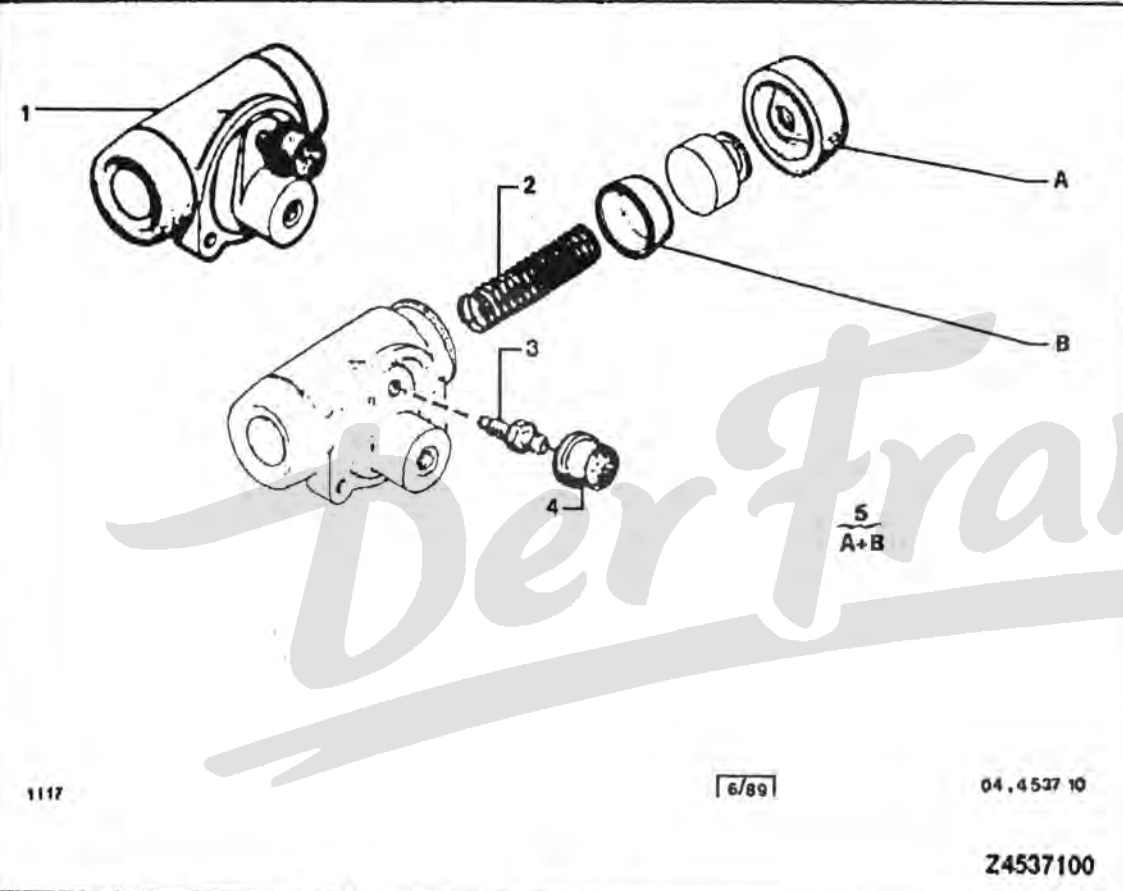

1117

6/89

04,4537 10

24537100

▶ 1665

LIQUIDE SYNTHETIQUE EXCLUSIVEMENT

01	5 488 527	02	DIAM 17,5	CYLINDRE ROUE RADBR.ZYLINDER WHEEL CYLINDER CILINDRO FRENO CILINDRO
02	AM 453 26	02		RESSORT FEDER PISTON SPING MUELLE MOLLA

**CYLINDRE DE ROUE ARRIERE**  
 HINTERE RADZYLINDER  
 REAR WHEEL CYLINDER  
 BOMBIN DE RUEDA TRAS.  
 CILINDRETTO RUOTA POST

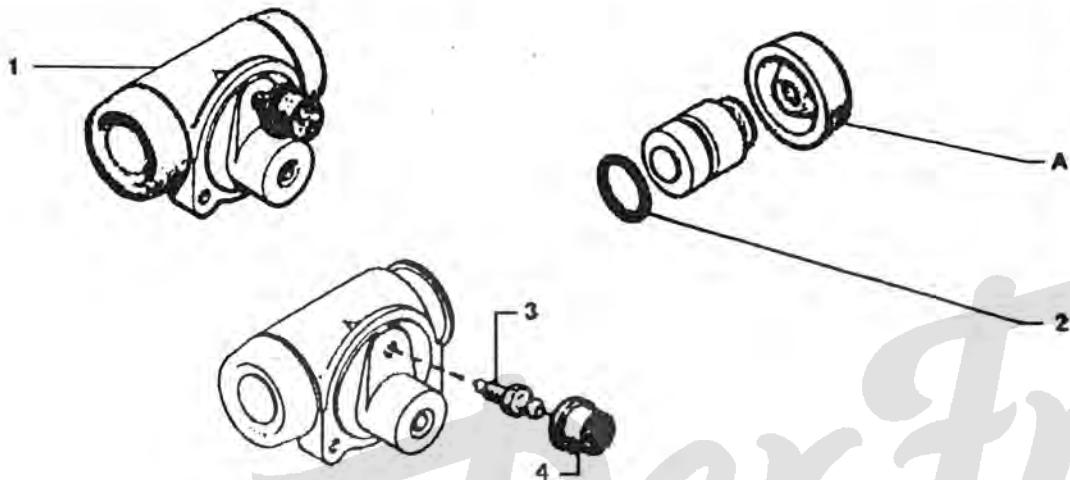

5  
 A+2

1117

789

04-4537-20

Z4537200

1666 ▶

LIQUIDE MINERAL EXCLUSIVEMENT

03	95 578 347	02	RMP DEO 7941401043	VIS DE PURGE ENTL-SCHRAUBE DRAIN SCREW TORNILLO PURGA VITE DI SPURGO
04	79 41 401 043	02		CAPUCHON PURGE KAPPE F ABLASS BLEED SCREW CAP CAPUCHON PURGA CUFFIA SPURGO
05	AMN 453 033 A	02	REDUIT	NEC DE CYLINDRE REP-SATZ ZYLIND BRAKE CYL KIT JUEGO REPAR NECESSARIO
01	AMN 453 05	02		CYLINDRE ROUE RADBR.ZYLINDER WHEEL CYLINDER CILINDRO FRENO CILINDRO
02	25 062 009	04	11.2X16,6 E 2.7	JOINT TORIQUE RINGDICHTUNG RING-SEAL JUNTA TORICA ANELLO TENUTA

15/02/91  
 1117 04-4550-10  
 PAGE : 1  
 D08 ↓

**FREIN A MAIN - TIRETTE**  
**HANDBREMSE - ZUGSTANGE**  
**HAND BRAKE - CONTROL ROD**  
**FRENO DE MANO - TIRADOR**  
**FRENO A MANO - TIRANTE**

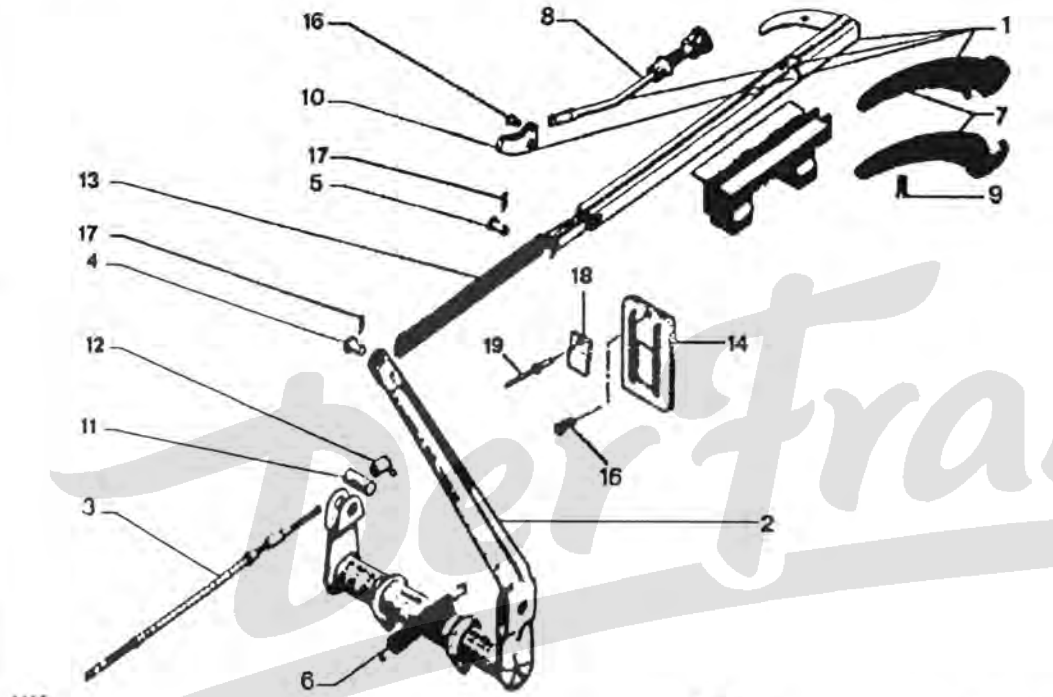

1117

8/89

04-4550 10

Z4550100

▶ 1665

01	5 403 367	01	LEVIER DE FREIN BREMSHEBEL HANDBRAKE LEVER PALANCA FRENO LEVA FRENO	04	A 314 92	01	6X17	AXE DE LEVIER HEBELBOLZEN LEVER PIN EJE PALANCA PERNO LEVA
02	AM 454 4	01		05	5 417 536	01	DIAM 6-LON 20	AXE BOLZEN SPINDLE EJE PERNO
03	AZ 454 1 F	02	LON 406	06	AM 454 9	01		RESSORT FEDER RETURN SPRING MUELLE MOLLA
				07	AM 454 249 A	01	ENS	POIGNEE GRIFF LEVER HANDLE EMPUNADURA FREN MANIGLIA
				08	5 403 363	01	AVEC BOUTON	TIGE DE CDE BETAETIG.STANGE CONTROL ROD VARILLA MANDO ASTA COMANDO
				09	79 03 005 061	02	4X12	VIS TFB METALISCHRAUBE METAL SCREW TORNILLO METAL VITE
				10	GX 42 186 01A	01		CLIQUET SPERRKLINKE LEVER PAWL TRINQUETE NOTTOLINO
				11	A 454 75	02	8,5X15X28	BARILLET BOLZEN CABLE BARREL BOMBILLO BARILETTO
				12	AY 454 74	02	DIAM 7X1.00	ECROU MUTTER NUT TUERCA DADO

.../...



15/02/91  
 1117 04-4550-10  
 PAGE : 2  
 D07 ↓

**FREIN A MAIN - TIRETTE**  
**HANDBREMSE - ZUGSTANGE**  
**HAND BRAKE - CONTROL ROD**  
**FRENO DE MANO - TIRADOR**  
**FRENO A MANO - TIRANTE**

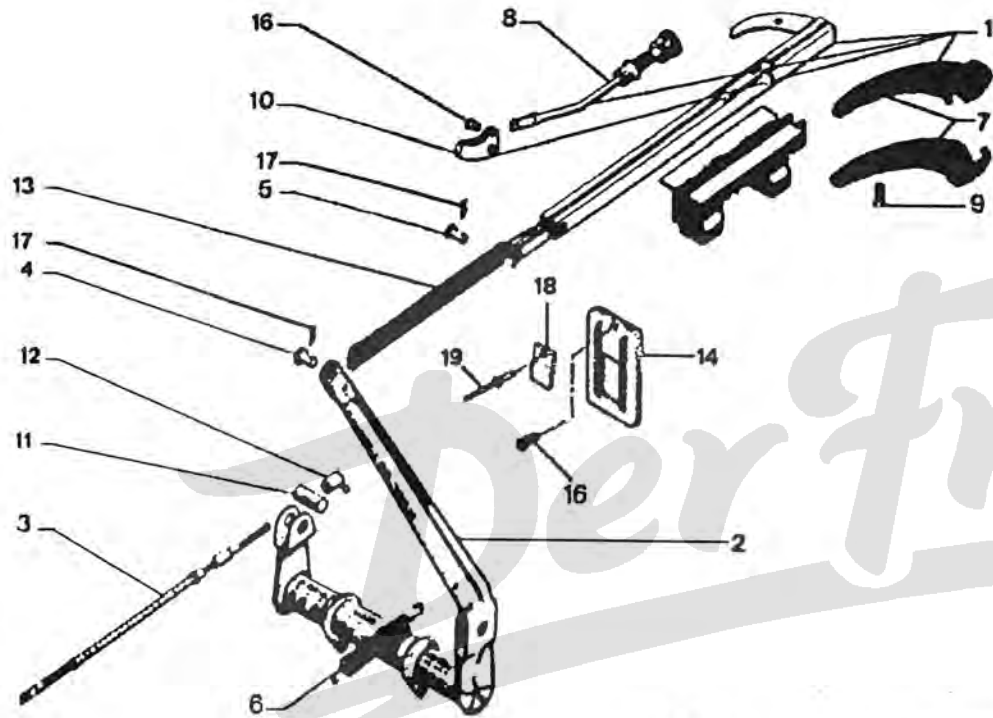

1117

6/89

04-4550 10

Z4550100

▶ 1665

15	79 03 077 078	01		BOUTON DE FIX KNOPF FIXING KNOB BOTON FIJACION BOTTONE FISSAGG
16	GX 42 306 01A NFP	01	DIAM 4,5-LON 385	AXE DE LEVIER HEBELBOLZEN LEVER PIN EJE PALANCA PERNO LEVA
17	79 03 066 999	02	DIAM 2-LON-20	EPINGLE SPANGE BRAKE PLATE PIN GRUPILLA SPILLO
18	95 551 818	01		PLAQUETTE PLATTE CABLE FIX PLATE PLAQUETA PIASTRINA
19	79 03 072 243	01	"POP" DIAM32	RIVET NIET RIVET REMACHE RIVETTO

13	AW 454 10	01	2DIAM8,5LON175	BIELLE LIAISON STANGE RELAY ROD BIELETA UNION BIELLA
14	5 432 385	01	31X57-1 DEO1-7903077078	PLAQUETTE PLATTE CABLE FIX PLATE PLAQUETA PIASTRINA

15/02/91  
1117 04-4550-20  
PAGE : 1  
D06 ↓

**FREIN A MAIN - TIRETTE**  
**HANDBREMSE - ZUGSTANGE**  
**HAND BRAKE - CONTROL ROD**  
**FRENO DE MANO - TIRADOR**  
**FRENO A MANO - TIRANTE**

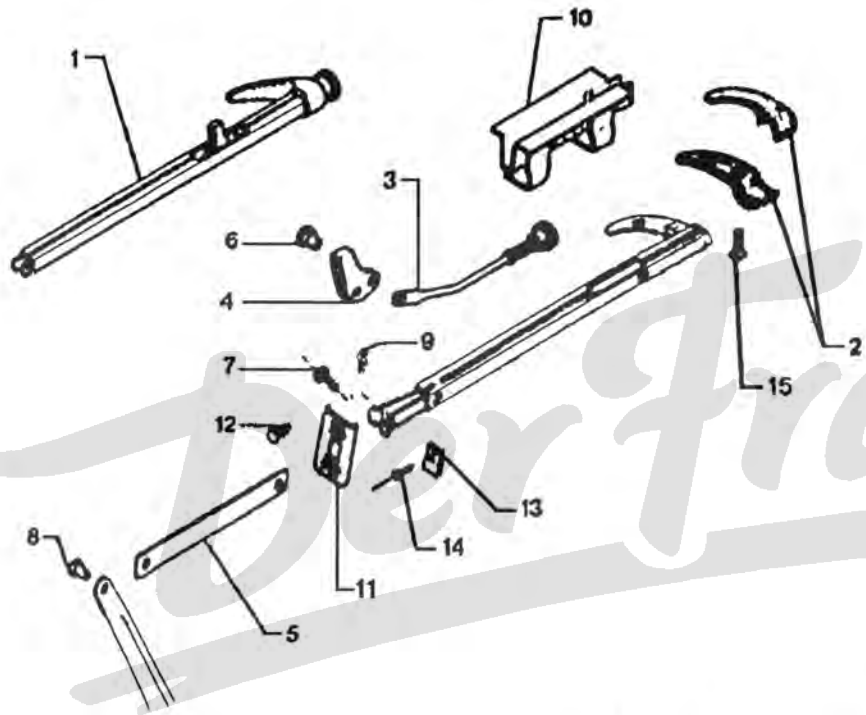

1117



04,4550,70

Z4550200

1668 ▶

01	95 551 820	01	LEVIER DE FREIN BREMSHEBEL HANDBRAKE LEVER PALANCA FRENO LEVA FRENO	03	95 551 821 NFP	01	AVEC BOUTON	TIGE DE LEVIER STANGE LEVER ROD VARILLA ASTA LEVA
02	AM 454 249 A	01	ENS	04	GX 42 186 01A	01		CLIQUET SPERRKLINKE LEVER PAWL TRINQUETE NOTTOLINO
				05	AW 454 10	01	2DIAM6.5LON175	BIELLE LIAISON STANGE RELAY ROD BIELETA UNION BIELLA
				06	GX 42 306 01A NFP	01	DIAM 4.5-LON 385	AXE DE LEVIER HEBELBOLZEN LEVER PIN EJE PALANCA PERNO LEVA
				07	5 417 536	01	DIAM 6-LON 20	AXE BOLZEN SPINDLE EJE PERNO
				08	A 314 92	01	6X17	AXE DE LEVIER HEBELBOLZEN LEVER PIN EJE PALANCA PERNO LEVA
				09	79 03 066 999	02	DIAM 2-LON-20	EPINGLE SPANGE BRAKE PLATE PIN GRUPILLA SPILLO
				10	AY 454 177	01		CREMAILLERE ZAHNSTANGE CONTROL RACK CREMALLERA CREMAGLIERA
				11	5 432 385	01		PLAQUETTE PLATTE CABLE FIX PLATE PLAQUETA PIASTRINA .../...

15/02/91  
 1117 04-4550-20  
 PAGE : 2  
 D05 ↓

**FREIN A MAIN - TIRETTE**  
**HANDBREMSE - ZUGSTANGE**  
**HAND BRAKE - CONTROL ROD**  
**FRENO DE MANO - TIRADOR**  
**FRENO A MANO - TIRANTE**

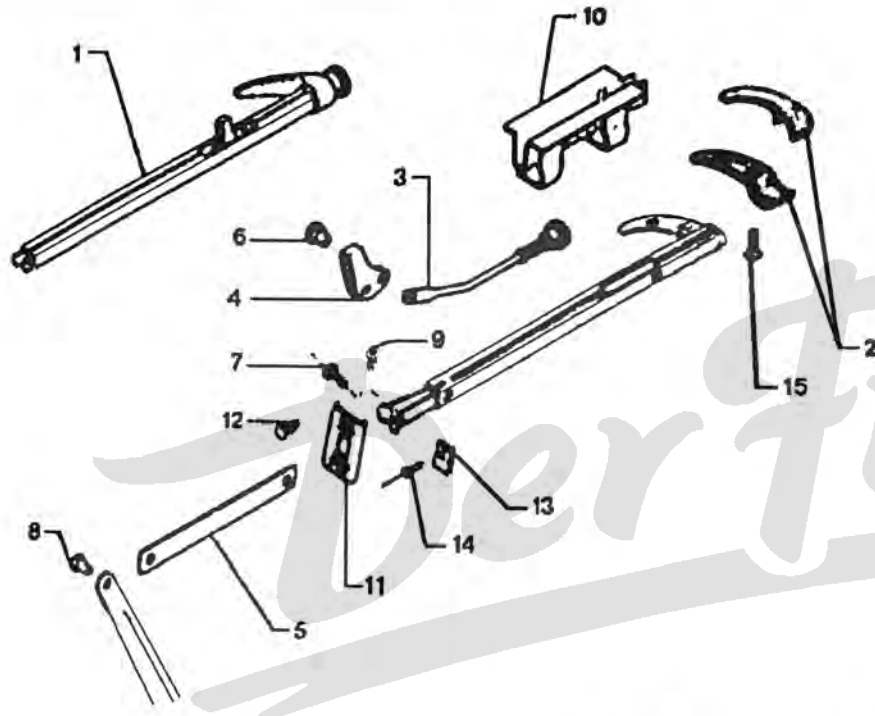

1117



04.4550.20

Z4550200

1666 ▶

12 79 03 077 078 01

**BOUTON DE FIX**  
**KNOPF**  
**FIXING KNOB**  
**BOTON FIJACION**  
**BOTTONE FISSAGG**

13 95 551 818 01

**PLAQUETTE**  
**PLATTE**  
**CABLE FIX PLATE**  
**PLAQUETA**  
**PIASTRINA**

14 79 03 072 243 01

"POP" DIAM32

**RIVET**  
**NIET**  
**RIVET**  
**REMACHE**  
**RIVETTO**

15 79 03 005 061 02

4X12

**VIS TFB**  
**METALISCHRAUBE**  
**METAL SCREW**  
**TORNILLO METAL**  
**VITE**

15/02/91  
1117 04-4555-10  
PAGE : 1  
D04 ↓

**FREIN A MAIN - LEVIER - CABLES**  
HANDBREMSE - HEBEL - SEILE  
HANDBRAKE - LEVER - CABLES  
FRENO DE MANO - PALANCA - CABLES  
FRENO A MANO - LEVA - CAVI

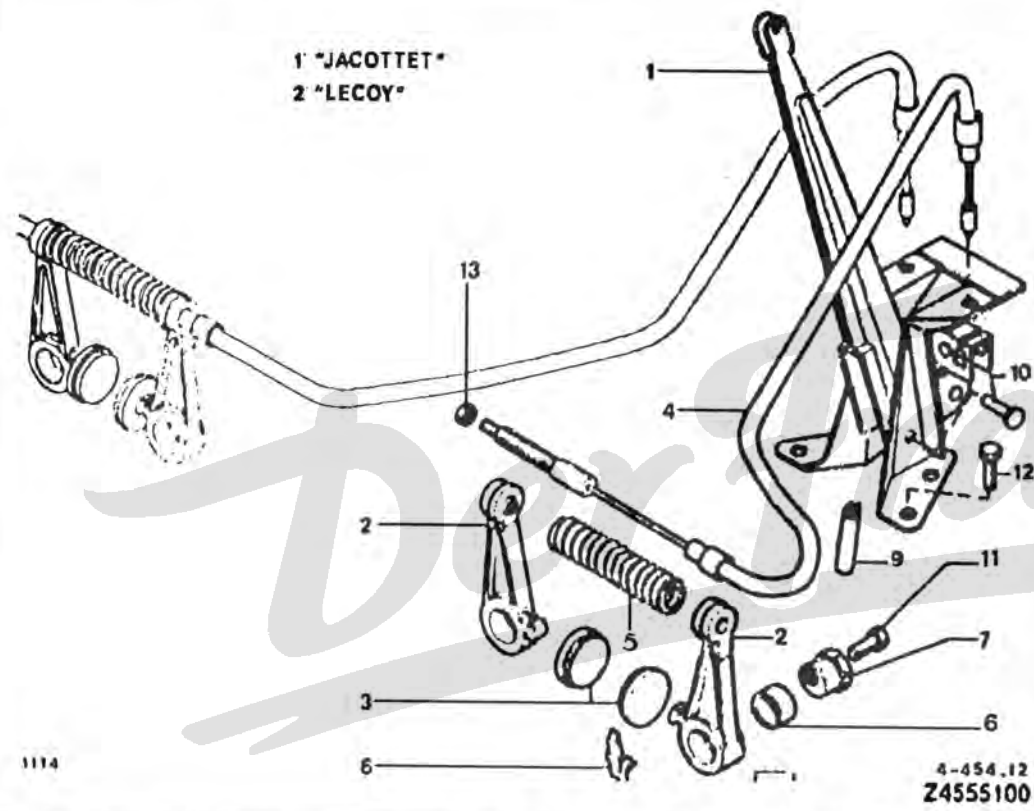

1 "JACOTTET"  
2 "LECOY"

1666 ▶

- 1 POS : "JACOTTET" 2 POS : "CASTELLON"

01	5 506 419	01	LEVIER HEBEL LEVER PALANCA LEVA
02	5 420 269	04	-
03	95 534 349	01	JEU 4 PLAQUETT. SATZ 4 BELAEGE SET 4 BRAKE PAD JUEGO 4 PASTIL SERIE 4 PIASTRE

04	75 492 021	01	G- LON 653-DIAM 7X1,00 1 POS	CABLE DE FREIN BREMSSEIL HANDBRAKE CABLE CABLE FRENO CAVO DEL FRENO
	75 491 848	01	D- LON 528 1 POS	-
	95 493 494	01	D- LON 390 2 POS	-
05	420 271	02	14 SPIRES	RESSORT FEDER RETURN SPRING MUELLE MOLLA
06	5 420 272	02	EXT G-INT D	-
	5 420 267	01	INT G-EXT D	-
07	5 435 903	04	DIAM 17,95 H15	EXCENTRIQUE EXZENTER ECCENTRIC EXCENTRICA ECCENTRICO
08	5 414 687	04	18X20X9,4	ENTRETOISE ABSTANDSSTUECK HANDBRAK SPACER DISTANCIADOR DISTANZIALE
09	5 465 744	01	LON 40	PROFILE SCHUTZLEISTE SECTION JUNTA PROTECCI. PROFILATO PROT
10	5 506 422	01	DIAM 10-LON 28,5	AXE DE LEVIER HEBELBOLZEN LEVER PIN EJE PALANCA PERNO LEVA
11	5 421 257	04	TH 9X1,25-35	VIS TH SCHRAUBE CAPSCREW TORNILLO TH VITE
12	79 03 101 769	04	DIAM 7X45	-

.../...

15/02/91  
 1117 04-4555-10  
 PAGE : 2  
 D03 ↓

**FREIN A MAIN - LEVIER - CABLES**  
**HANDBREMSE - HEBEL - SEILE**  
**HANDBRAKE - LEVER - CABLES**  
**FRENO DE MANO - PALANCA - CABLES**  
**FRENO A MANO - LEVA - CAVI**

54

75 491 847

01 G. LON 708  
 -CAD

**XT**

**CABLE DE FREIN**  
**BREMSEIL**  
**HANDBRAKE CABLE**  
**CABLE FRENO**  
**CAVO DEL FRENO**

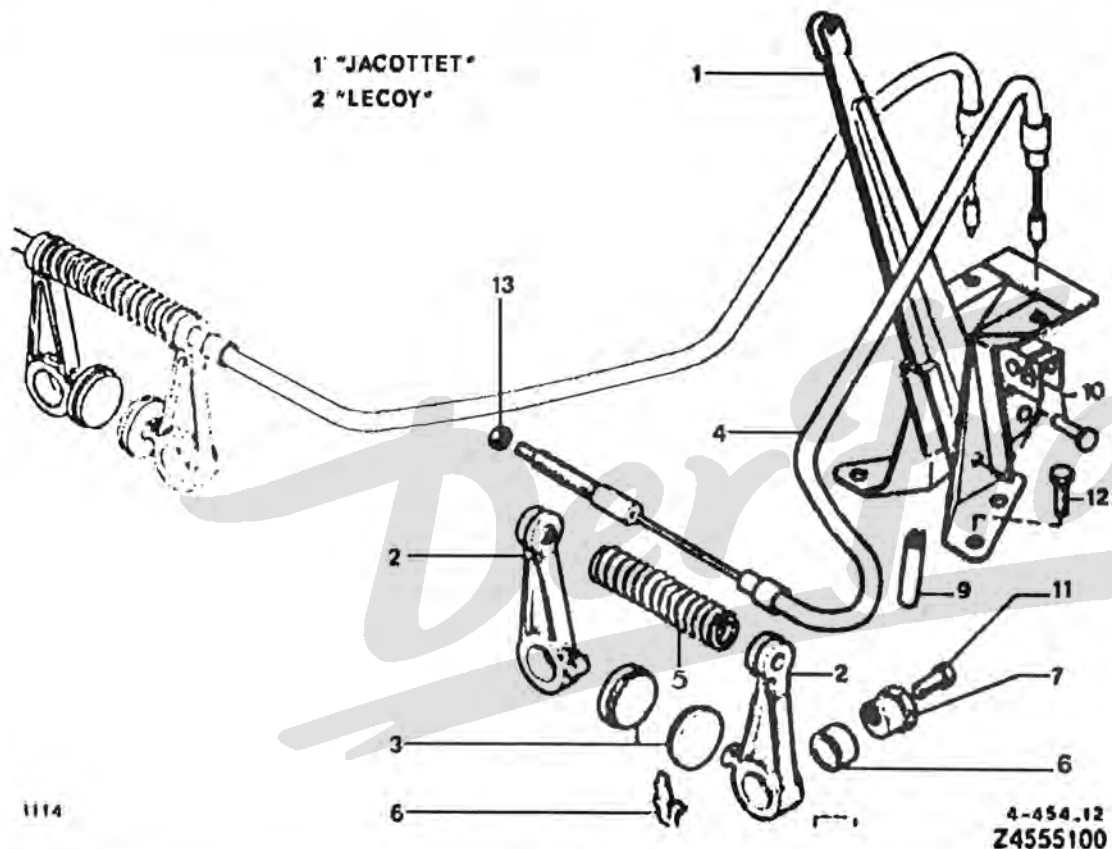

1114

1666 ▶

13	79 03 032 036	02 HE 7X1,00-5,5	ECROU MUTTER NUT TUERCA DADO
	79 03 032 071	02 H 7 X 1,00 H 3,5	ECROU HEXAGONAL SECHSKANTMUTTER HEXAGONAL NUT TUERCA DADO ESAGONALE

NUMERO	SOUS-GROUPE	REP	NUMERO	SOUS-GROUPE	REP	NUMERO	SOUS-GROUPE	REP	NUMERO	SOUS-GROUPE	REP
5 403 207	04-4512-11	06	21 589 009	04-4530-10	11	95 538 713	04-4535-20	07		04-4512-10	10
5 403 208		07	21 888 009	04-4530-15	09		04-4535-10	07	A 451 86	04-4515-20	10
5 403 363	04-4550-10	08	23 836 019	04-4535-20	09	95 547 230	04-4512-11	14	A 451 87		11
5 403 367		01		04-4535-10	09	95 551 818	04-4550-20	13	A 454 18	04-4517-10	14
5 405 104	04-4512-11	08		04-3140-11	16		04-4550-10	18	A 454 13 A		14
5 410 804	04-3140-11	07		04-3140-10	16	95 551 820	04-4550-20	01	A 454 75	04-4550-10	11
	04-3140-10	08	25 062 009	04-4537-20	02	95 551 821		03	AM 174 221 A	04-4533-15	11
5 411 956	04-4530-10	14	25 413 010	04-3140-11	19	95 554 041	04-4536-10	04		04-4530-10	16
	04-4530-15	10	26 150 010	04-3140-10	10	95 554 585	04-4535-10	02	AM 314 55	04-3140-11	10
5 413 895	04-4530-10	15	26 190 519	04-4512-10	06	95 555 655		01		04-3140-10	10
	04-4530-15	13		04-4515-20	13	95 562 402		11	AM 331 86 A	04-3733-10	05
5 414 687	04-4555-10	08	26 199 449	04-4533-15	12	95 562 403	04-4535-20	11	AM 371 3		04
5 417 536	04-4550-20	07		04-4530-10	13	95 566 670	04-3140-11	01	AM 371 3 A		04
	04-4550-10	05	26 199 999		55		04-3140-10	51	AM 371 92		06
	04-3140-10	09	75 434 307	04-4512-11	12			01	AM 451 018 A	04-4515-20	05
	04-3140-11	09	75 486 303	04-4535-10	04	95 566 706	04-3733-10	03	AM 451 21 A		06
5 417 537		11		04-4535-20	04	95 575 913	04-3140-11	04	AM 452 80	04-4512-11	13
	04-3140-10	11	75 491 743	04-4535-10	03		04-3140-10	04	AM 452 81		13
5 420 183	04-4512-11	04	75 491 744	04-4535-20	03	95 578 347	04-4536-10	02	AM 452 96		15
5 420 184		10	75 491 847	04-4555-10	54		04-4537-10	03	AM 453 134	04-4530-15	07
5 420 264		16	75 491 848		04		04-4537-20	03		04-4530-10	09
5 420 267	04-4555-10	06	75 492 021		04	95 578 349	04-4512-11	11	AM 453 211	04-4535-20	05
5 420 269		02	75 492 434	04-4536-10	01	95 578 362		11		04-4535-10	05
5 420 271		05	75 511 681	04-4535-10	11	95 583 487	04-4536-10	04	AM 453 26	04-4537-10	02
5 420 272		06	75 515 584	04-3140-15	08	95 587 148	04-4512-11	09	AM 453 33 D	04-4530-10	05
5 420 471	04-3140-10	07		04-3140-11	06	95 588 594	04-4535-20	02		04-4530-15	04
	04-3140-11	09	75 516 219	04-4512-11	03	95 588 595		01	AM 453 333 A	04-4530-10	56
5 421 257	04-4555-10	11	75 516 220		03	95 599 322	04-4512-11	02		04-4530-15	54
5 421 919	04-4530-10	06	75 516 490	04-3733-10	02	95 602 714	04-3733-10	12	AM 454 249 A	04-4550-10	07
	04-4530-15	05	75 522 848	04-4530-10	51	95 615 119		13		04-4550-20	02
5 421 822		06	75 522 849		54	95 618 235	04-4515-20	15	AM 454 4	04-4550-10	02
	04-4530-10	07		04-4530-15	53	95 618 237		15	AM 454 9		06
5 422 483	04-3140-11	15	75 525 808	04-3733-10	01	95 623 757	04-4512-11	18	AMN 453 033 A	04-4537-20	05
	04-3140-10	15	75 527 579		09	95 641 001	04-4530-10	02	AMN 453 05		01
5 426 248	04-4512-10	01	75 527 610		19	95 653 061	04-4512-11	53	AW 454 10	04-4550-10	13
5 426 249		01	75 529 692	04-4530-15	02	96 995 250	04-4530-10	10		04-4550-20	05
5 432 385	04-4550-20	11	75 529 694		52		04-4530-15	08	AY 314 3 A	04-3140-11	03
	04-4550-10	14	75 529 696		52	A 314 92	04-4550-10	04		04-3140-10	03
5 435 903	04-4555-10	07	75 529 700		01		04-4550-20	08	AY 451 6 A	04-4512-10	03
5 438 258	04-3140-10	13	95 493 138	04-4535-10	08	A 372 48 A	04-3733-10	11	AY 453 100	04-3140-10	14
	04-3140-11	13		04-4535-20	08	A 451 14 B	04-4512-10	09		04-3140-11	14
5 438 353	04-4530-10	08	95 493 494	04-4555-10	04	A 451 15 B		13	AY 453 175	04-4530-10	12
5 444 063	04-4530-15	53	95 494 917	04-3140-10	02	A 451 15 C	04-4515-20	03	AY 453 205	04-4535-10	06
5 447 525	04-4530-10	01		04-3140-11	02	A 451 16		04		04-4535-20	06
5 465 744	04-4555-10	09	95 494 918	04-3140-10	52		04-4512-10	08	AY 453 25	04-3140-11	12
5 472 299	04-4530-10	04		04-3140-11	52	A 451 2		04		04-3140-10	12
	04-4530-15	53	95 498 712	04-3733-10	16	A 451 3	04-4515-20	02	AY 453 333 A	04-4530-10	03
5 488 527	04-4537-10	01	95 532 941		17	A 451 75	04-4512-10	07	AY 453 342 A	04-4530-15	03
5 506 419	04-4555-10	01	95 532 947		18	A 451 83		11	AY 454 177	04-4550-20	10
5 506 422		10	95 534 349	04-4555-10	03		04-4515-20	09	AY 454 74	04-4550-10	12
5 506 709	04-4537-10	05	95 535 826	04-4512-11	01	A 451 85		07	AYB 453 352 A	04-3140-10	05

B04 ↑

INDEX

Catalogue 1117

NUMERO	SOUS-GROUPE	REP	NUMERO	SOUS-GROUPE	REP
	04-3140-11	05	79 03 032 070	04-4512-10	17
AZ 451 016 A	04-4512-10	02	79 03 032 071	04-4555-10	13
AZ 451 17		05	79 03 032 247	04-3140-10	20
AZ 451 202 A	04-4515-20	01		04-3140-11	20
AZ 451 65		08		04-4535-20	10
AZ 454 1 F	04-4550-10	03		04-4535-10	10
GX 25 266 01A	04-4512-11	05	79 03 053 390	04-4512-10	18
GX 42 186 01A	04-4550-10	10	79 03 056 020	04-3140-11	17
	04-4550-20	04		04-3140-10	17
GX 42 306 01A		06	79 03 066 999	04-4550-20	09
	04-4550-10	16		04-4550-10	17
ZC 9438 157 U	04-4515-20	12	79 03 072 243	04-4550-20	14
	04-4512-10	12		04-4550-10	19
ZC 9612 644 U	04-3733-10	07	79 03 077 078	04-4550-20	12
ZC 9615 030 U	04-4512-10	19		04-4550-10	15
ZD 9249 400 U		18	79 03 083 153	04-3733-10	16
79 03 005 061	04-4550-10	09	79 03 083 156		15
	04-4550-20	15	79 03 083 250		14
79 03 032 036	04-4555-10	13	79 03 090 190		08
	04-4515-20	14	79 03 101 769	04-4555-10	12
	04-3140-11	18	79 03 201 020	04-4512-10	15
	04-3140-10	18	79 03 201 130	04-4512-11	17
			79 41 401 043	04-4537-20	04
				04-4537-10	04
				04-4538-10	03

15/02/91 1117 <b>TABEAU DES VUES</b> AUFSTELLUNG DER BILDER TABLE OF PICTURE B01 ↑ TABLA DE VISTAS TABELLA DELLE VEDUTE	<b>GROUPE</b> GROUP GROUP <b>05</b> GRUPO GRUPPO			<b>ECLAIRAGE AVANT - FIXATION</b> BELEUCHTUNG VORNE - BEFESTIGUNG FRONT LIGHTING - SECURING ILUMINACION DELANTERA - SUJECION ILLUMINAZIONE ANTERIORE - FISSAGGIO	5410-10	C15 D15
<b>SOUS-GROUPE</b> UNTERGRUPPE SUBGROUP SUBGRUPO SOTTOGRUPPO		<b>NUMERO</b> NUMMER NUMBER NUMERO NUMERO	<b>VUE</b> BILD PICTURE VISTA VEDUTA	<b>ECLAIRAGE AVANT</b> BELEUCHTUNG VORNE FRONT LIGHTING ILUMINACION DELANTERA ILLUMINAZIONE ANTERIORE	5410-20	D14 D13
<b>CABLERIE - FAISCEAUX - FILS</b> KABELBUENDEL - SATZ KABEL - KABEL HARNESS - SETS OF LEADS - LEADS HACES DE CABLES - CABLES FASCI - CAVETTI  - SPECIALE CAD		5110-10 5110-11	C02 C03	<b>BARRE DE PHARES - COMMANDE</b> HALTER - BETAETIGUNG BRACKET-LIGHTING SOPORTE-MANDO SUPPORTO-COMANDO	5416-10	D12 D11
<b>EQUIPEMENT ELECTRIQUE</b> ELEKTRISCHE AUSSTATTUNG ELECTRIC EQUIPMENT EQUIPO ELECTRICO IMPIANTO ELETTRICO		5121-10	C04 C05 C06	<b>ECLAIRAGE ARRIERE</b> BELEUCHTUNG HINTEN REAR LIGHTING ILUMINACION TRASERA ILLUMINAZIONE POSTERIORE	5440-10 5440-20	D10 D09 D08
<b>COFFRET DE LAMPES - LAMPES</b> GLUEHBIRNENSATZ LAMP KIT CAJA DE LAMPARAS - LAMPARAS COFRANETTO LAMPADE - LAMPADE		5127-20	C07	<b>ESSUIE VITRE</b> SCHEIBENWISCHER WINDSCREEN WIPER LIMPIA-PARABRISAS TERGICRISTALLO	5610-10	D07 D06 D05
<b>TABEAU DE BORD - APPAREILS DE CONTROLE</b> ARMATURENBRETT - UEBERWACHUNGSINSTRUMENT INSTRUMENT PANEL CHECKING APPARATUS TABLERO DE INSTRUMENTOS - TESTIGOS QUADRO STRUMENTAZIONE - SPIE		5213-10 5213-20	C08 C09 C10 C11 C12 C13	<b>LAVE VITRE</b> SCHEIBENWASCHANLAGE WINDSCREEN WASHER LAVA-CRISTAL LAVACRISTALLO	5640-10	D04 D03
- SPECIALE				<b>AVERTISSEUR SONORE</b> HORN HORN INDICADOR SONORO AVVISATORE SONORO	5710-10	D02
<b>BATTERIE</b> BATTERIE BATTERY BATERIA BATTERIA		5310-10	C14	<b>FUSIBLES MANOCONTACT CONTACTEUR</b> SICHERUNG - DRUCKSCHALTER FUSES-PRESSURE-SWITCHES FUSIBLES-MANOCONTACTOS-CONTACTORES FUSIBILI-MANOCONTATTI-CONTATTORI	6144-10	D01 E01



/02/91 17 05-5110-10 AGE : 1 02 ↑	<b>CABLERIE - FAISCEAUX - FILS</b> KABELBUENDEL - SATZ KABEL - KABEL HARNESS - SETS OF LEADS - LEADS HACES DE CABLES - CABLES FASCI - CAVETTI	50	5 486 524 NFP	01 DEUX ALLURES -(N)	FAISCEAU E-V AV KABELSTRANG WDW WIPR HARNES CABLEADO FASCIO
			<b>XT</b>		
(XT) - (SAUF CAD)		51	75 522 250 NFP	01 -(I) ▶ 05/80	FSC AV HAUPTKABEL FRONT HARNESS CABLEADO AV FASCIO CAVI ANT
5 486 493	01 -SPECIALE ▶ 05/80				
95 550 633	01 -SPECIALE 05/80 ▶ 1666 -		95 550 635	01 -CLUB -(I) 05/80 ▶ -	
95 564 177	01 -SPECIALE 1666 ▶ 3461 -		95 550 634 NFP	01 -SPECIALE -(I) 05/80 ▶ 1666 -	
5 486 487	01 ▶ 05/80 -		95 564 178	01 -SPECIALE -(I) 1666 ▶ -	
95 550 636	01 05/80 ▶ 1666 -		96 016 832	01 -(DK) 3762 ▶ -	
95 564 179	01 -SPECIALE 3464 ▶ 3492 -		96 075 818	01 -(D) 07/88 ▶ -	
95 637 254	01 3493 ▶ 3856 -		52 5 486 519 NFP	01 -(B) ▶ 3492	FSC AR KABELSTRANG REAR HARNESS CABLEADO AR FASCIO POST.
96 016 831	01 3857 ▶ -				
5 486 513	01 ▶ 3492	FSC AR KABELSTRANG REAR HARNESS CABLEADO AR FASCIO POST.	95 637 258	01 -(B) 3493 ▶ -	
95 637 257	01 3493 ▶ -		55 5 486 253 NFP	01 DANS TABLEAU DE BORD -(B)	FSC FEU BROUIL KABELSTRANG FOG LAMP HARNES CABLEADO FASCIO
5 461 150	02	FSC PROJEC KABELSTRANG HDLIGHT HARNESS CABLEADO FASCIO	60 5 489 145	01 D'ALIMENTATION FEU -(B)	
95 631 999	01 SIGNAL DE DETRESSE -(I) 3157 ▶	FSC AR KABELSTRANG REAR HARNESS CABLEADO AR FASCIO POST	5 489 146	01 D'ALIMENTATION FEU -SPECIALE -(B)	

15/02/91 1117 05-5110-11 PAGE : 1 C03 ↑	<b>CABLERIE - FAISCEAUX - FILS</b> KABELBUENDEL - SATZ KABEL - KABEL HARNESS - SETS OF LEADS - LEADS HACES DE CABLES - CABLES FASCI - CAVETTI
--	---

**SPECIALE CAD**

01	95 575 409	01	1666 ▶ 3461	FSC AV HAUPTKABEL FRONT HARNESS CABLEADO AV FASCIO CAVI ANT
	95 543 808	01	▶ 1666 -	
	95 564 180	01	-SPECIALE -CAD 1666 ▶ 3492 -	
			-CAD 06/81 ▶ 3492	
	95 637 255	01	3493 ▶ -	
02	5 486 513	01	1701 ▶ 3492	FSC AR KABELSTRANG REAR HARNESS CABLEADO AR FASCIO POST.
	95 637 258	01	3493 ▶ -	
03	5 461 150	01		FSC PROJEC KABELSTRANG HDLIGHT HARNESS CABLEADO FASCIO

**EQUIPEMENT ELECTRIQUE**  
 ELEKTRISCHE AUSSTATTUNG  
 ELECTRIC EQUIPMENT  
 EQUIPO ELECTRICO  
 IMPIANTO ELETTRICO

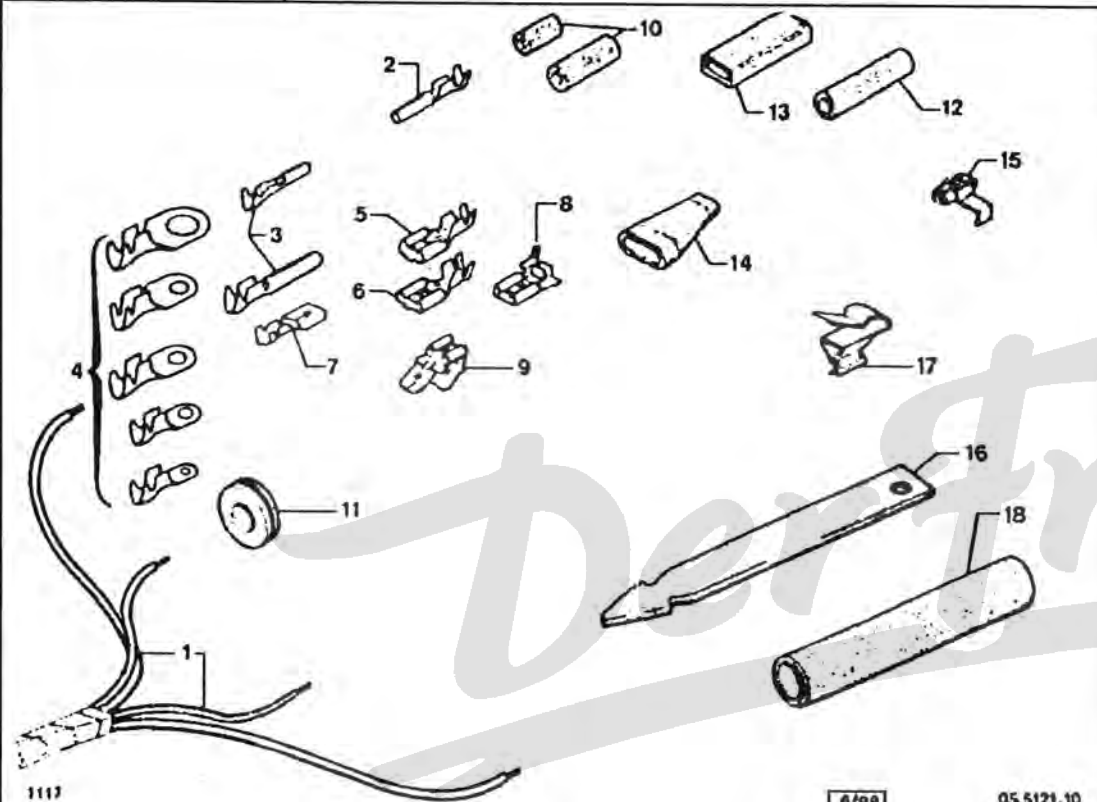

1117 [e'99] 05.5121.10  
 Z5121100

01	ZC 9003 732 U	99 20/10	FSC ELECTRIQUE KABELSTRANG ELECTRIC HARNES CABLEADO FASCIO ELETTR.	02	5 420 487	99 DIAM 4-FEMELLE	COSSE KABELSCHUH WIRE TERMINAL TERMINAL CAPOCORDA
	ZC 9003 733 U	99 12/10	-	03	AZ 512 4	99 DIAM 3-MALE	-
02	AZ 512 3	99 DIAM 3-FEMELLE	COSSE KABELSCHUH WIRE TERMINAL TERMINAL CAPOCORDA	04	5 412 276	99 DIAM 4-MALE	-
					ZC 9614 540 U	99 DIAM 3,25	-
					ZC 9614 541 U	99 DIAM 4,5	-
					26 145 429	99 DIAM 5,5	-
					96 995 683	99 DIAM 6,25 COSSEAOEIL	COSSES ELECTRI KABELSCHUHE ELECTR TERMINAL TERMINAL CAPOCORDA ELETT
					26 145 449	99 DIAM 8,5	COSSE KABELSCHUH WIRE TERMINAL TERMINAL CAPOCORDA
				05	5 412 142	99 DIAM 6X35 FEMELLE	CLIP FAISCEAU STECKVERBINDER HARNES CLIP CLIP CABLEADO GRAFFETTA
				06	DX 511 99	99 LAR 6,35 AVEC ERGOT	
					95 544 487	99 LAR 6,35 FEM-ALTERNA	COSSE KABELSCHUH WIRE TERMINAL TERMINAL CAPOCORDA
				07	5 412 143	99 LAR 6,35 LON 8 MALE	LANGUETTE STECKVERBINDUNG HARNES BLADE TERMINAL CABLE NOTTOLINO
				08	5 407 093	99 DIAM 6,35 DRAPEAU	CLIP FAISCEAU STECKVERBINDER HARNES CLIP CLIP CABLEADO GRAFFETTA
				09	5 412 809	99 1 FEM-2 MALES	...J...

15/02/91  
 1117 05-5121-10  
 PAGE : 2  
 C05 ↑

**EQUIPEMENT ELECTRIQUE**  
 ELEKTRISCHE AUSSTATTUNG  
 ELECTRIC EQUIPMENT  
 EQUIPO ELECTRICO  
 IMPIANTO ELETTRICO

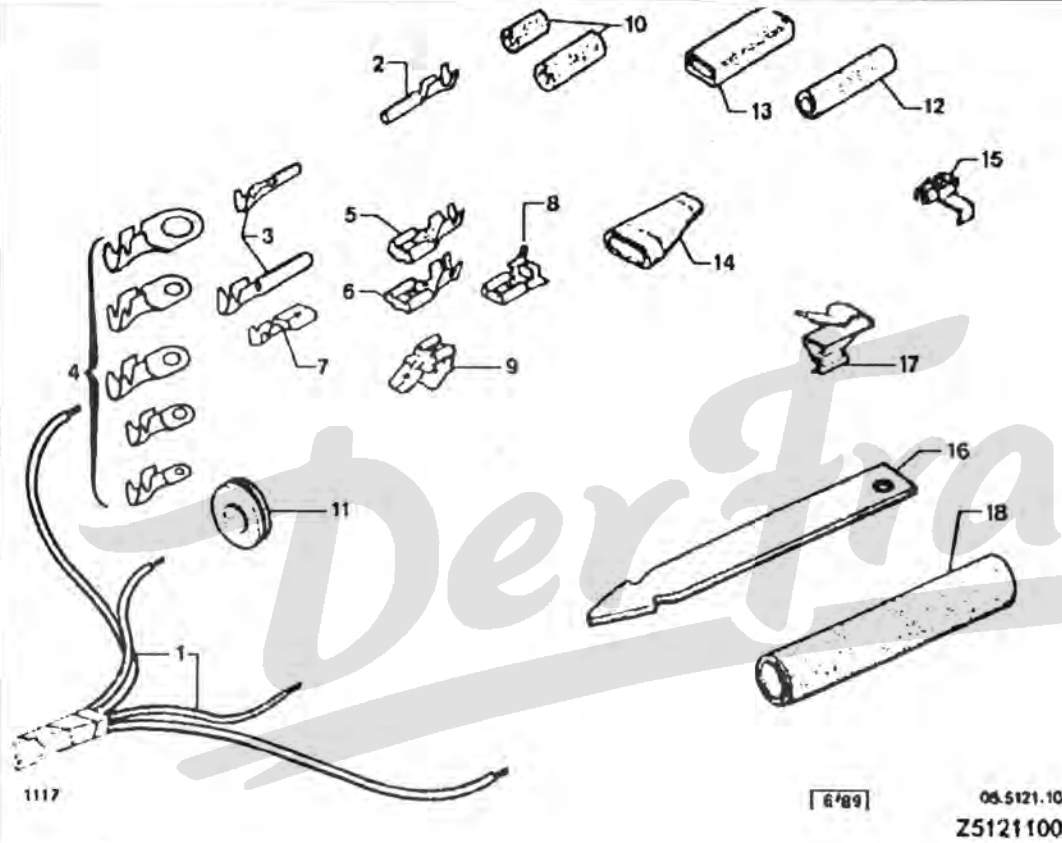

10	75 528 522	99 3X8X12 FEMELLE CAOUTCHOUC	CACHE ABDECKUNG CONNECTOR COVER TAPA CONECTOR TAPPO
	5 420 488	99 3,5X3,5X20 FEMELLE CAOUTCHOUC	-
11	21 061 009	99 8X18X4 CAOUTCHOUC	OEILLET GUMMIOESE RUBBER GROMMET PASACABLE OCCHIELLO

11	21 062 009	99 12X21X5	OEILLET GUMMIOESE RUBBER GROMMET PASACABLE OCCHIELLO
	21 063 009	99 14X26X6	-
	21 064 009	99 16X32X7 CAOUTCHOUC	-
	21 065 009	99 22X38X8	-
12	DX 511 151 A	99 POUR COSSE ET FICHE	CACHE ABDECKUNG CONNECTOR COVER TAPA CONECTOR TAPPO
13	5 465 935	99 CLIP FEMELLE 6,35	-
14	5 457 472	99 CLIP MALE 6,35	PROTECTEUR HALTECLIPS PROTECTOR PROTECTOR TAPPO
15	26 146 469	99 DOUBLE FONCTION	CONNECTEUR STECKVERBINDER HARN CONNECTOR CONECTADOR CONNETTORE
16	26 142 289	99 CAOUTC LONG 272	COLLIER SCHELLE ADJUST COLLAR ABRAZADERA COLLARE
17	26 198 639	02 DIAM 8	AGRAFE KLAMMER CLIP GRAPA AGRAFE
	AY 511 72	03 CABLERIE PORTE AR	-
18	5 489 489	01 DIAM 17 LONG 220 VIN	GAINÉ SCHUTZHUELLE PROTECT SHEATH VAINA GUAINA

.../...

15/02/91  
 1117 05-5121-10  
 PAGE : 3  
 C06 ↑

EQUIPEMENT ELECTRIQUE  
 ELEKTRISCHE AUSSTATTUNG  
 ELECTRIC EQUIPMENT  
 EQUIPO ELECTRICO  
 IMPIANTO ELETTRICO

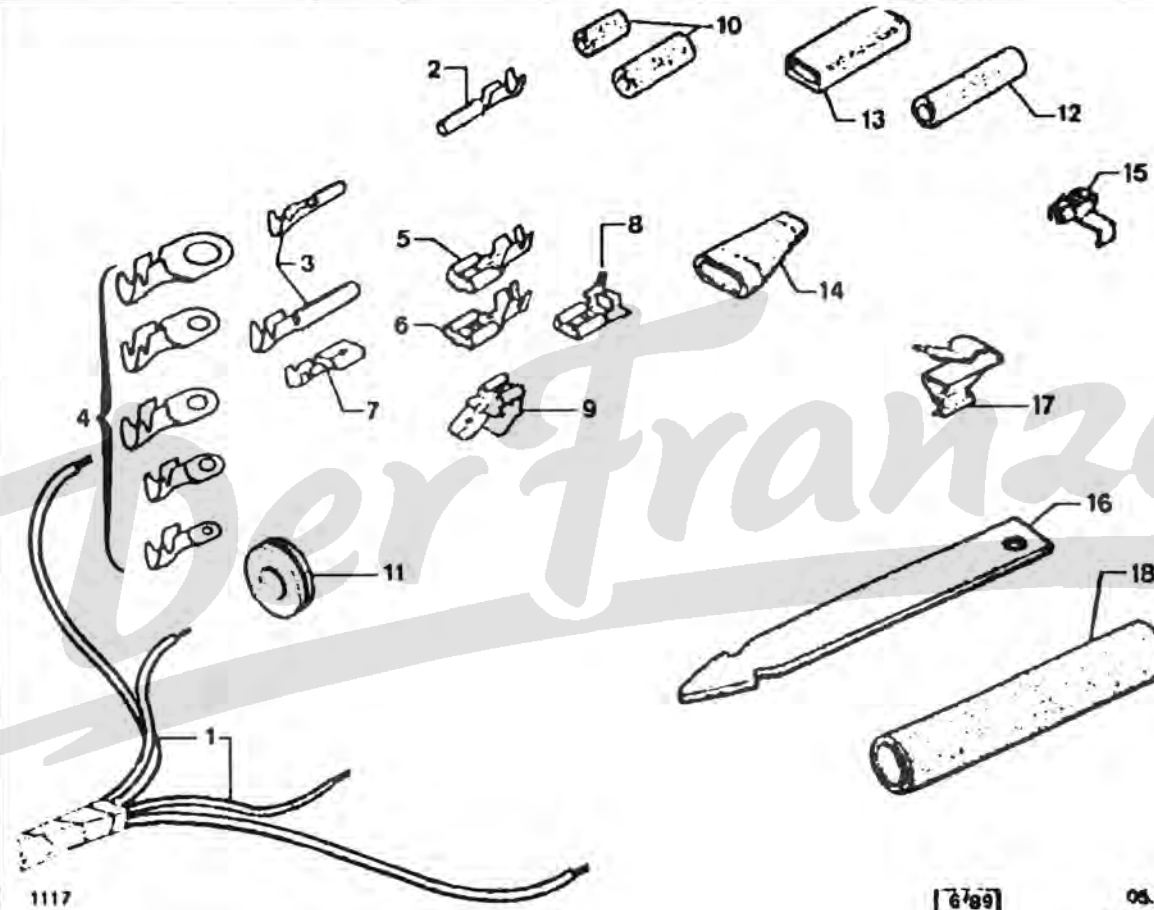

1117

[6789]

05.5121.10  
 Z5121100

19	79 03 097 996	99	1 VOIE	PORTE-LANGUETTE STECKZUNGHALTER BLADE-HOLDER PORTA LENGUETAS PORTALINGUETTA
	79 03 097 997	99	5 VOIES	

15/02/91  
1117 05-5127-20  
PAGE : 1  
C07 ↑

**COFFRET DE LAMPES - LAMPES**  
**GLUEHBIRNENSATZ**  
**LAMP KIT**  
**CAJA DE LAMPARAS - LAMPARAS**  
**COFRANETTO LAMPADE - LAMPADE**

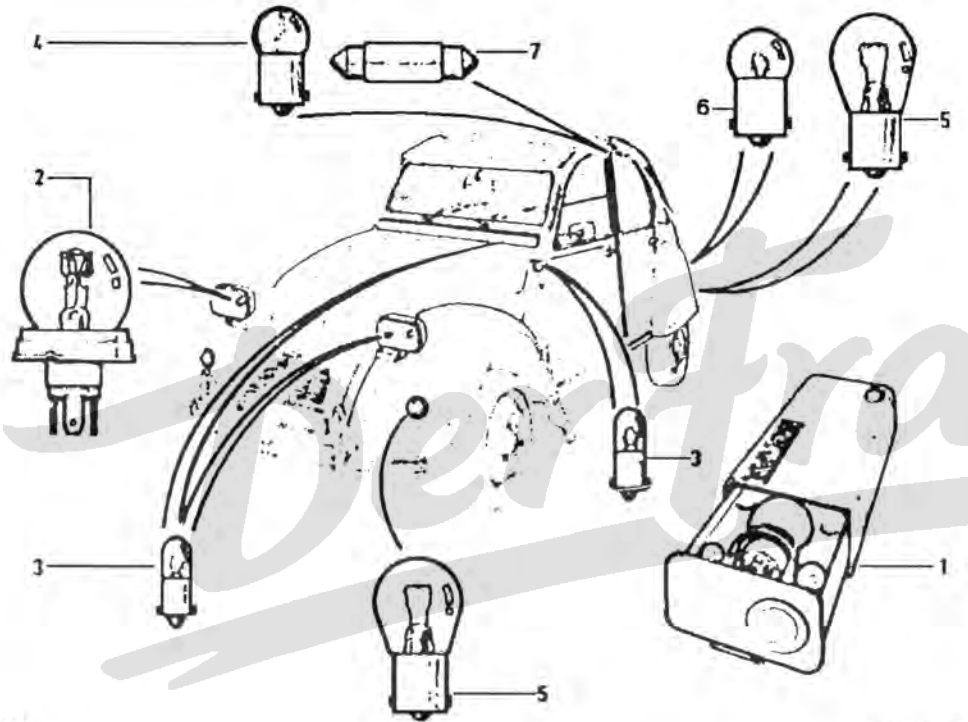

1114

5-512-20  
Z5127200

- REP 3:25908009 (VOYANT ROUGE + FEU DE POSITION )
- REP 3:25907009 (VOYANT VERT + FEU LATERAL + VOYANT BLEU + ECLAIRAGE TABLEAU)
- REP 4:25917009 (ECLAIRAGE INTERIEUR)
- REP 5:25926009 (DE STOP + INDICATEUR DIRECTION)
- REP 6:25919009 (FEU DE POSITION + ECLAIREUR DE PLAQUE)

01	ZC 9875 631 U	01	ECLAIRAGE JAUNE H4	BOITE DE LAMPES BIRNENSATZ BULB KIT ESTUCHE LAMPARA SCATOLA LAMPADE
----	---------------	----	--------------------	---

02	26 109 009	02	45/40W NORMA	LAMPE GLUEHBIRNE HEADLIGHT LAMP LAMPARA DE FARO LAMPADA FARO
	ZC 9865 189 U RP 26109009	02	45-40W ISKRA	-
03	25 908 009	01		LAMPE 4 W GLUEHLAMPE 4W LAMP 4W LAMPARA 4 W LAMPADINA 4W
	25 907 009	01	2W	LAMPE GLUEHBIRNE LAMP LAMPARA LAMPADA
04	25 917 009	01	12 V-7 W-NORMA 1408	-
05	25 926 009	02	21W SPOT INT	-
06	25 919 009	01	12 V	-
			<b>XT</b>	
51	ZC 9865 452 U NFP	01	COFFRET N4 EXPORT	BOITE DE LAMPES BIRNENSATZ BULB KIT ESTUCHE LAMPARA SCATOLA LAMPADE
71	26 108 009	02	40/45W	LAMPE GLUEHBIRNE HEADLIGHT LAMP LAMPARA DE FARO LAMPADA FARO
81	26 101 009	01	12V - 5vV -CAD	LAMPE NAVETTE SOFFITTENBIRNE PILOT LAMP LAMPARA NAVETA LAMPADA

**TABLEAU DE BORD - APPAREILS DE CONTROLE**  
**ARMATURENBRETT - UEBERWACHUNGSINSTRUMENT**  
**INSTRUMENT PANEL-CHECKING APPARATUS**  
**TABLERO DE INSTRUMENTOS - TESTIGOS**  
**QUADRO STRUMENTAZIONE - SPIE**

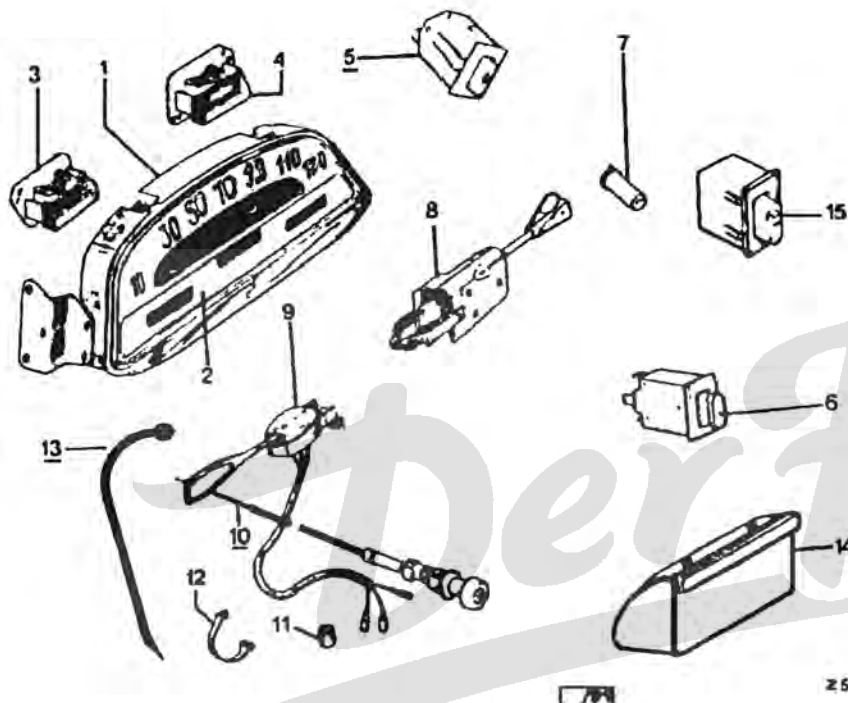

Z5213100

Z5213100

- LES REPERES NON REFERENCES SONT NFP

01	5 505 569	01	JAEGER	COMBINE COMPLET INSTR-TAFEL KPL INSTRUM CLUSTER CUADRO COMPLETO QUADRO STRUM.
02	5 508 653	01	VEGLIA	VITRE COMBINE SCHEIBE GLASS VIDRIO VETRO
	5 509 285	01	JAEGER	

03	75 518 873	01	VEGLIA	RECEPTEUR EMPFAENGER FUEL GAUGE INDICADOR RICEVITORE
	5 442 904	01	JAEGER	-
04	5 469 954	01	VEGLIA	VOLTMETRE VOLTMETER VOLTMETER VOLTIMETRO VOLTOMETRO
05	95 493 838	01	ESSUIE-VITRE DAV	1665 INTERRUPTEUR SCHALTER CONTROL SWITCH INTERRUPTOR INTERRUPTORE
06	5 491 286	01	DAV	CDE SIGNAL DANG SCHALTER WARNING SWITCH MANDO WARNING COMANDO
	5 481 270	01	NIVOCODE	INTERRUPTEUR SCHALTER SWITCH INTERRUPTOR INTERRUPTORE
07	GX 41 404 01A	01	PRESSION HUILE	VOYANT TABLEAU ARM.BRETTLEUCHT WARNING LIGHT INDICADOR TABLE SPIA QUADRO
08	HY 522 01 B	01	PHARE + AVERTISSEUR	INTERRUPTEUR SCHALTER SWITCH INTERRUPTOR INTERRUPTORE
09	75 491 742	01	CLIGNOTANT S/SBRUIT CARTIER	-
10	5 491 384	01		CABLE STARTER STARTERZUG CHOKE CABLE CABLE ESTARTER CAVC STARTER

15/02/91  
1117 05-5213-10  
PAGE : 2  
C09 ↑

**TABLEAU DE BORD - APPAREILS DE CONTROLE**  
**ARMATURENBRETT - UEBERWACHUNGSINSTRUMENT**  
**INSTRUMENT PANEL-CHECKING APPARATUS**  
**TABLERO DE INSTRUMENTOS - TESTIGOS**  
**QUADRO STRUMENTAZIONE - SPIE**

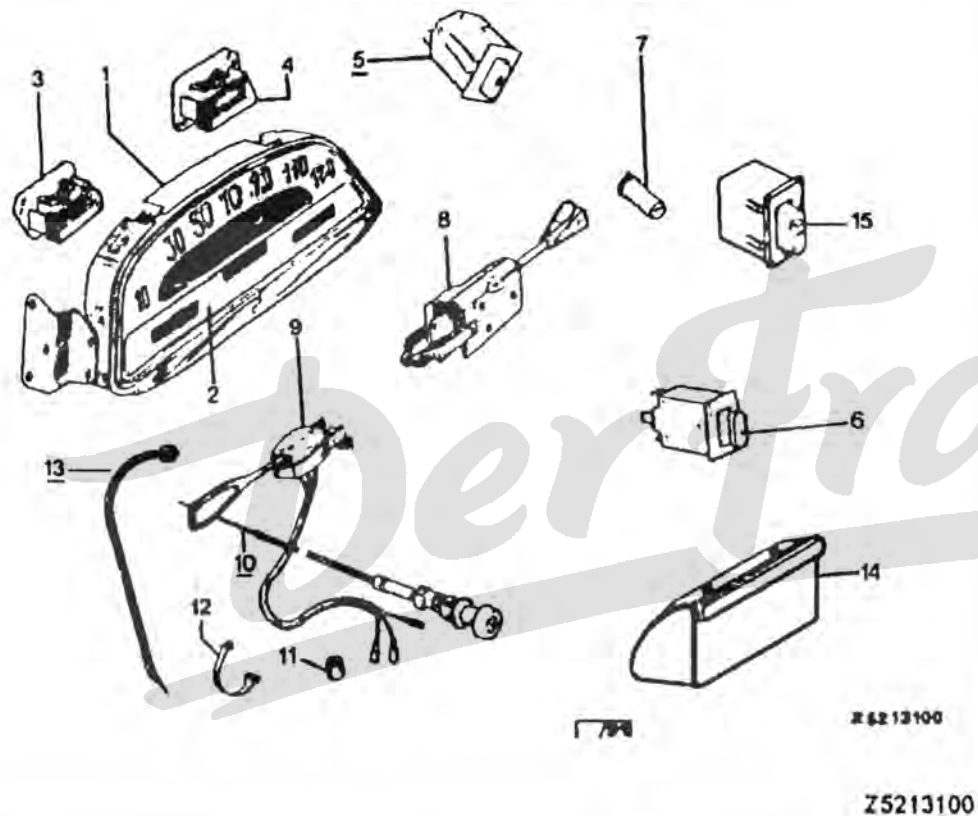

11	75 412 806 NFP	01 16X8X20 CAOUTCHOUC	BAGUE DURCHGANGSRING RUNNING RING CASQUILLO BOCCOLA PASSAG
	5 413 895	01 9X21X30	BAGUE FIX HALTERING FIXING RING CASQUILLO BOCCOLA

12	26 142 289	01 CAOUTC LONG 272	COLLIER SCHELLE ADJUST COLLAR ABRAZADERA COLLARE
13	AK 521 3 B	01	FLEXIBLE COMPT. WELLE SPEEDOMET CABLE CABLE FLESSIBILE
14	5 440 875	01 AV	CENDRIER ASCHENBECHER ASHTRAY CENICERO PORTACENERE
15	75 492 223	01 DAV -FEUX DE BROUILLARD AR	INTERRUPTEUR SCHALTER SWITCH INTERRUPTOR INTERRUPTORE
<b>XT</b>			
53	5 490 332	01 -(N)	CDE ESSUIE LA-V SCHALTER WASWIPE SWITCH MANDO COMANDO
60	95 597 848	01 LON 955 SEIM	CDE DE STARTER CHOKEBETAETIGUM CHOKE CONTROL TIRADOR ESTARTE COM.STARTER
63	AM 521 282 A	01 LON 1025 -CAD	FLEXIBLE COMPT. WELLE SPEEDOMET CABLE CABLE FLESSIBILE
70	GX 41 400 01A	01 DE FEU POSITION	VOYANT TABLEAU ARM.BRETTLEUCH WARNING LIGHT INDICADOR TABLE SPIA OUAORO
	GX 41 402 01A	01 BLEU DE PHARES	-



15/02/91  
 1117 05-5213-10  
 PAGE : 3  
 C10 ↑

**TABLEAU DE BORD - APPAREILS DE CONTROLE**  
**ARMATURENBRETT - UEBERWACHUNGSINSTRUMENT**  
**INSTRUMENT PANEL-CHECKING APPARATUS**  
**TABLERO DE INSTRUMENTOS - TESTIGOS**  
**QUADRO STRUMENTAZIONE - SPIE**

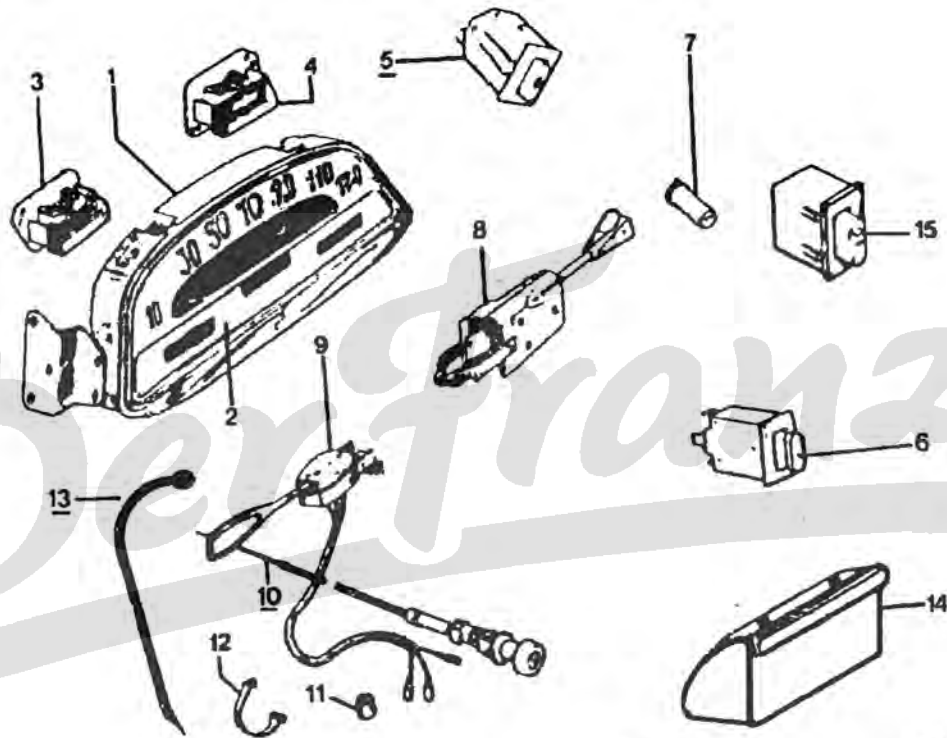

7/89

Z 62 13100

Z5213100

71	5 490 423	01 AVERTISSEUR OPTIQUE -(A) -(D)	CDE ECLAIRAGE BETAETIGUNG LIGHTING SWITCH MANDO COMANDO
72	75 525 042	01 LUNETTE AR CHAUFFANT DAV -CAD	CDE LUNETTE CH. SCHALTUNG TAILGATE SWITCH MANDO COMANDO

15/02/91  
1117 05-5213-20  
PAGE : 1  
C11 ↑

**TABLEAU DE BORD - APPAREILS DE CONTROLE**  
**ARMATURENBRETT - UEBERWACHUNGSINSTRUMENT**  
**INSTRUMENT PANEL-CHECKING APPARATUS**  
**TABLERO DE INSTRUMENTOS - TESTIGOS**  
**QUADRO STRUMENTAZIONE - SPIE**

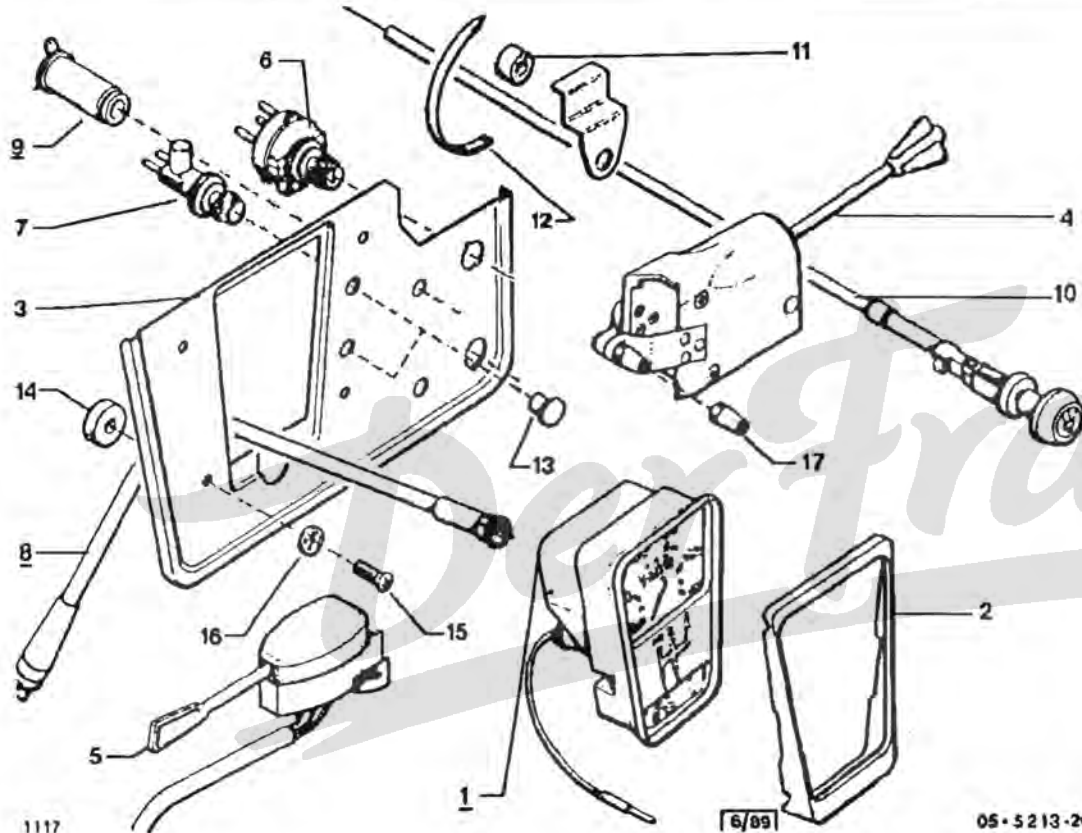

1117

[6/89]

05-5213-20

Z5213200

**SPECIALE**

01	5 490 893	01	COMPLET (KM) JAEGER	TABLEAU DE BORD ARMATURENBRETT INSTRUMENT PANEL TABLERO INSTRUM QUADRO
02	AZ 521 20	01		FACADE BLENDE INSTR CLST FACE FACHADA FACCIATA

03	95 567 394	01	1666 ▶ 2730	SUPPORT COMBIN HALTER CLUSTER BRACKE SOPORTE SUPPORTO
	95 531 885	01	2732 ▶	-
04	HY 522 01 B	01	PHARE + AVERTISSEUR	INTERRUPTEUR SCHALTER SWITCH INTERRUPTOR INTERRUPTORE
05	5 491 054 NFP	01	FEUX DIRECTION	CDE ECLAIRAGE BETAETIGUNG LIGHTING SWITCH MANDO COMANDO
	5 491 519 RP 75491742	01	INDICATEUR DIRECTION	-
06	AZ 522 222 A	01	SIGNAL DETRESSE ▶ 2731	-
	5 491 286	01	DAV 2732 ▶	CDE SIGNAL DAN SCHALTER WARNING SWITCH MANDO WARNIN COMANDO
07	5 427 285	01	SEIMA ▶ 1665	CDE ESSUIE LA-V SCHALTER WASWIPE SWITCH MANDO COMANDO
	95 494 957	01	SEIMA 1666 ▶ 2701	-
	95 493 838	01	ESSUIE-VITRE DAV 2731 ▶	INTERRUPTEUR SCHALTER CONTROL SWITC INTERRUPTOR INTERRUPTORE
	AY 522 273 A	01	DE LAVE GLACE	-
08	AK 521 3 B	01		FLEXIBLE COMP' WELLE SPEEDOMET CAE CABLE FLESSIBILE ...

15/02/91  
 1117 05-5213-20  
 PAGE : 2  
 C12 ↑

**TABLEAU DE BORD - APPAREILS DE CONTROLE**  
 ARMATURENBRETT - UEBERWACHUNGSINSTRUMENT  
 INSTRUMENT PANEL-CHECKING APPARATUS  
 TABLERO DE INSTRUMENTOS - TESTIGOS  
 QUADRO STRUMENTAZIONE - SPIE

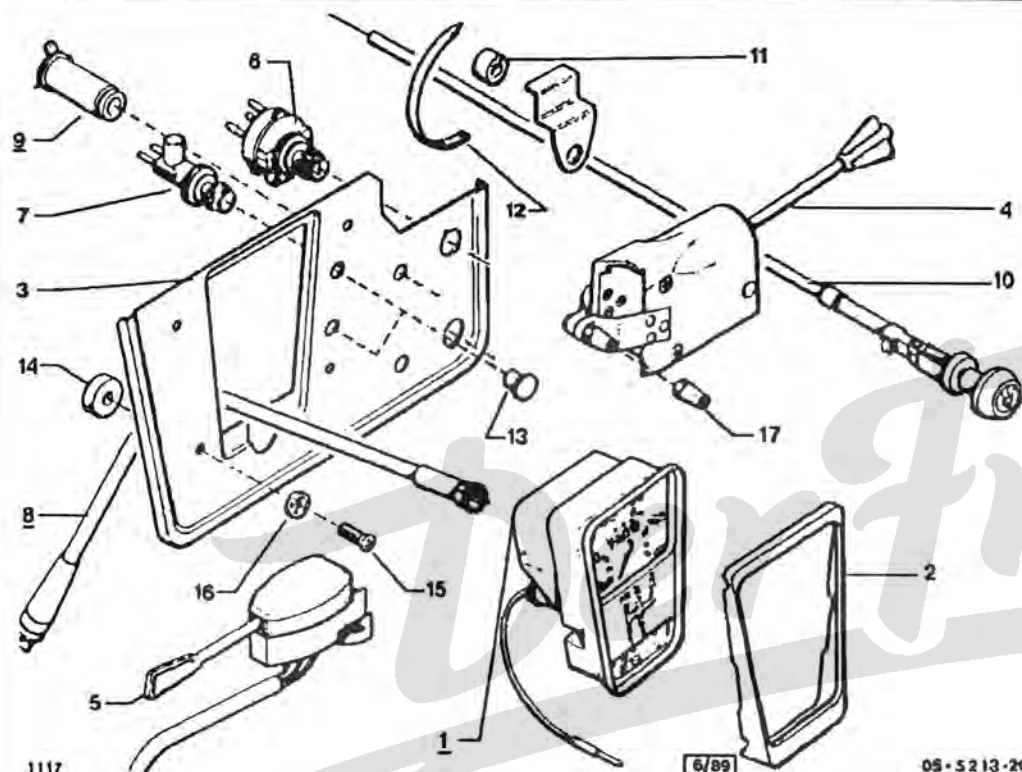

1117

[6/89]

05-5213-20  
 Z5213200

**SPECIALE**

09	GX 41 404 01A	03	PRESSION HUILE	VOYANT TABLEAU ARM.BRETTLEUCHT WARNING LIGHT INDICADOR TABLE SPIA QUADRO
10	95 597 848	01	LON 955 SEIM	CDE DE STARTER CHOKEBETAETIGUN CHOKE CONTROL TIRADOR ESTARTE COM.STARTER

11	75 412 806 NFP	01	16X6X20 CAOUTCHOUC	BAGUE DURCHGANGSRING RUNNING RING CASQUILLO BOCCOLA PASSAG
	5 413 895	01	9X21X30	BAGUE FIX HALTERING FIXING RING CASQUILLO BOCCOLA
12	26 142 289	01	CAOUTC LONG 272	COLLIER SCHELLE ADJUST COLLAR ABRAZADERA COLLARE
13	5 500 852*706	01	DIAM 10,2X14-H:11	OBTURATEUR STOPFEN FACIA PNL PLUG OBTURADOR TAPPO
14	5 475 738	04	DIAM 24-EP:6	ENTRETOISE ABSTANDSSTUECK SPACER JUEGO DISTANCIA DISTANZIALE
15	24 708 009	04		VIS TFB METALISCHRAUBE METAL SCREW TORNILLO METAL VITE
16	79 03 057 066	04	DIAM 5	RONDELLE CUVETT NAPFSCHEIBE CUP WASHER ARANDELA RONDELLA PIATTE
17	5 413 594	01	HE5X0,80	ECROU HEXAGONAL SECHSKANTMUTTER HEXAGONAL NUT TUERCA DADO ESAGONALE
51	5 414 284	01	COMPLET 120 KMS -(CH)	<b>XT</b>  TABLEAU DE BORD ARMATURENBRETT INSTRUMENT PANEL TABLERO INSTRUM QUADRO

.../...

15/02/91  
1117 05-5213-20  
PAGE : 3  
C13 ↑

**TABLEAU DE BORD - APPAREILS DE CONTROLE**  
**ARMATURENBRETT - UEBERWACHUNGSINSTRUMENT**  
**INSTRUMENT PANEL-CHECKING APPARATUS**  
**TABLERO DE INSTRUMENTOS - TESTIGOS**  
**QUADRO STRUMENTAZIONE - SPIE**

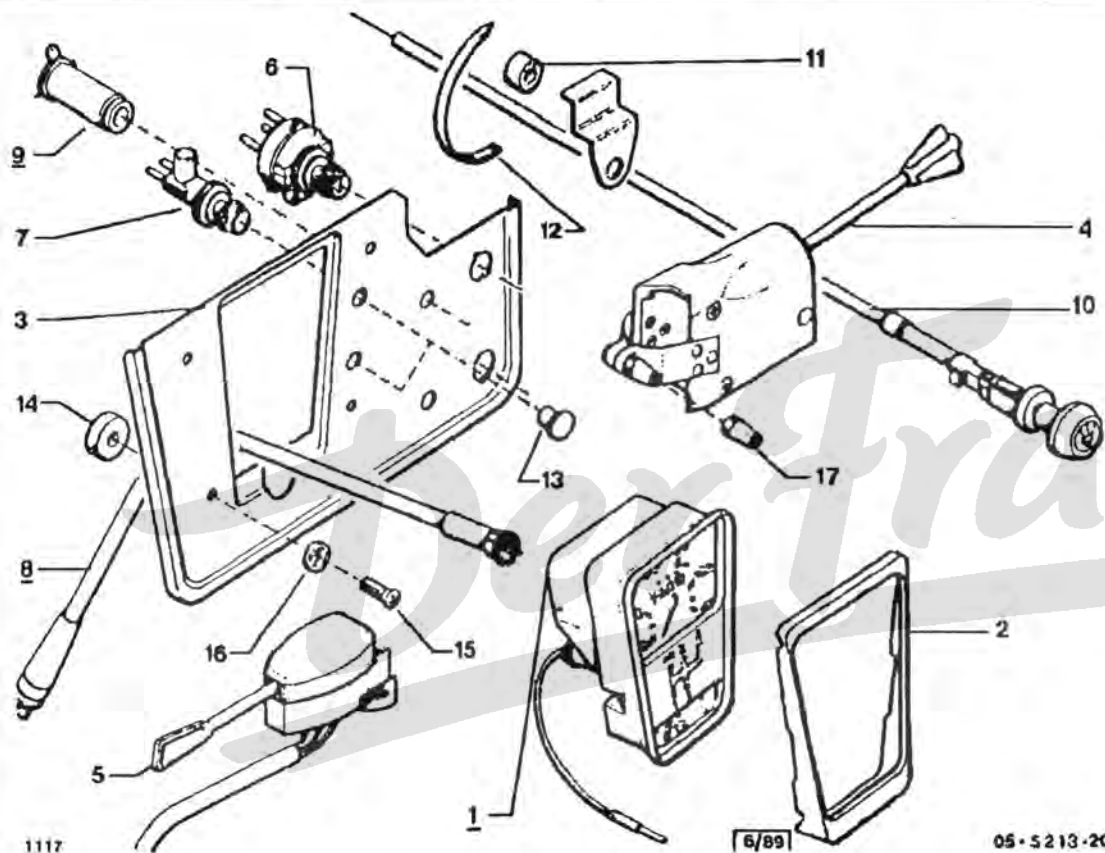

**SPECIALE**

51	95 495 349	01 COMPLET 120 KMS JAEGER -CAD	1666 ▶	TABLEAU DE BORD ARMATURENBRETT INSTRUMENT PANEL TABLERO INSTRUM QUADRO
58 *	AM 521 282 A	01 LON 1025 -CAD	1666 ▶	FLEXIBLE COMPT. WELLE SPEEDOMET CABLE CABLE FLESSIBILE

59 *	GX 41 402 01A	01 BLEU DE PHARES	VOYANT TABLEAU ARM.BRETTLEUCHT WARNING LIGHT INDICADOR TABLE SPIA QUADRO
	GX 41 400 01A	01 DE FEU POSITION	-
	AY 522 273 A	01 DE LAVE GLACE	INTERRUPTEUR SCHALTER SWITCH INTERRUPTOR INTERRUPTORE
	79 03 074 999	01 DIAM 16	OBTURATEUR STOPFEN PLUG OBTURADOR OTTURATORE

15/02/91  
 1117 05-5310-10  
 PAGE : 1  
 C14 ↑

**BATTERIE**  
 BATTERIE  
 BATTERY  
 BATERIA  
 BATTERIA

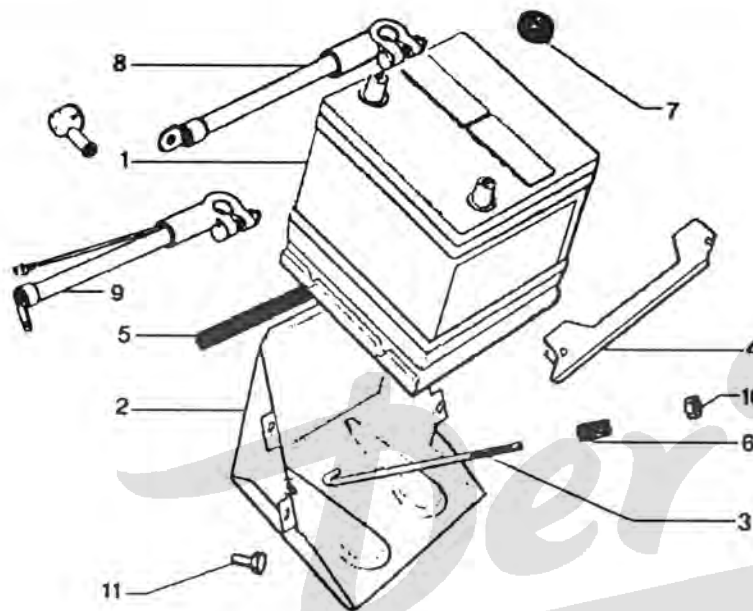

1117

6/89

5-531-10

25310100

01	ZC 9865 474 U	01	35 AH SANS ENTRETIEN	BATTERIE BATTERIE DRY BATTERY BATERIA BATTERIA
02	AZU 531 91	01		SUPPORT HALTER BATTERY TRAY SOPORTE BATERIA SUPPORTO

03	AZ 531 87 C	02	LON 225	TIRANT FIXATION BEF-STREBE RETAINING HOOK TIRANTE TIRANTE
04	5 467 554	01		BRIDE BATTERIE STEG FIXING FLANGE BRIDA BATERIA STAFFA
05	D 743 91	01	SUP-LON 950 CAOUTCHOUC	ETANCHEITE ABDICHTUNG SEALING ESTANQUEIDAD TENUTA
06	AM 531 72	02	DIAM INT 5,5	RESSORT FEDER BAT HOOK SPRING MUELLE MOLLA
07	75 444 179	01	16X40X3 ▶ 1685	RONDELLE FEUTRE FILZSCHEIBE FELT WASHER ARANDELA RONDELLA FELTRO
08	5 444 664	01	LON 0,560	CABLE POSITIF PLUSKABEL POSITIVE CABLE CABLE POSITIVO CAVO POSITIVO
09	5 443 554	01	LON 0,590	CABLE NEGATIF MINUSKABEL NEGATIVE CABLE CABLE NEGATIVO CAVO NEGATIVO
10	ZD 9232 300 U	02	DIAM 5X0.75	ECROU HEXAGONAL SECHSKANTMUTTER HEXAGONAL NUT TUERCA DADO ESAGONALE
11	79 03 201 130	04	DIAM 5 X 0.80 - 16	VIS TH SCHRAUBE CAPSCREW TORNILLO TH VITE

15/02/91  
 1117 05-5410-10  
 PAGE : 1  
 C15 →

**ECLAIRAGE AVANT - FIXATION**  
 BELEUCHTUNG VORNE - BEFESTIGUNG  
 FRONT LIGHTING - SECURING  
 ILUMINACION DELANTERA - SUJECION  
 ILLUMINAZION ANTERIORE - FISSAGGIO

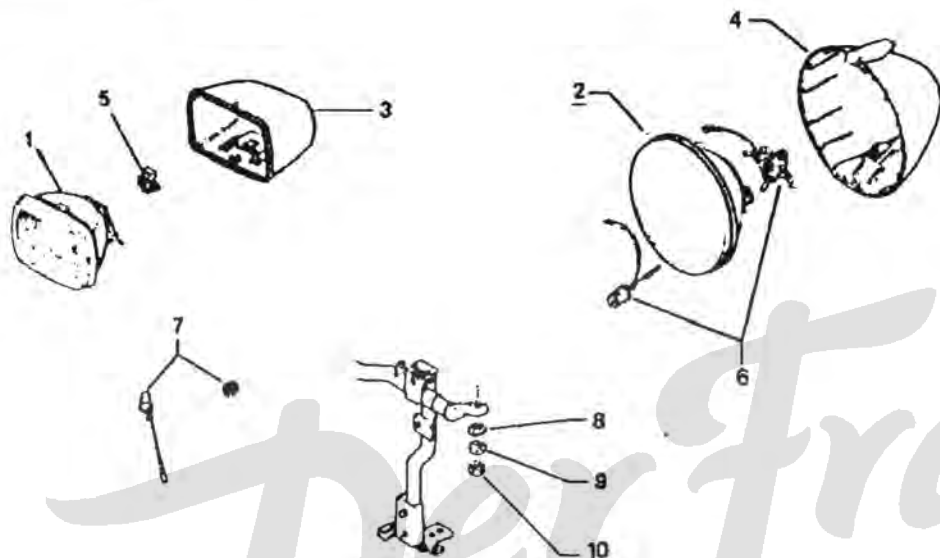

1117

[6/89]

05.5410 10

Z5410100

- 1 POS: TOLE 2 POS: PLASTIQUE

01	95 623 250	02 SANS LAMPES 1 POS	BLOC OPTIQUE LEUCHTEINHEIT HEADLIGHT BLOQUE OPTICO BLOCCO OTTICO
	5 505 727	02 SANS LAMPES 2 POS	-
02	95 623 247	02 ROND 2 POS	-

03	95 623 227	02 1 POS	CUVELAGE GEHAUSE BEAM UNIT BODY SOPORTE FARO RIVESTIMENTO
	95 505 725	02 RECTANGULAIRE 2 POS	-
04	95 623 228	02 ROND 1 POS	-
	95 576 540	02 ROND-1 POS -CHARLESTON 1666 ▶	-
05	5 422 618 RP 7903097289	02 "AMP"	CONNECTEUR STECKVERBINDER BULB CONNECTOS COHECTADOR CONNETTORE
	95 623 249	02 1 POS	POCHETTE SATZ CONNECTOR POUCH JUEGO CONEXION. BUSTA
07	95 623 273	01 2 POS	-
08	5 443 127	02 FIX DES PHARES	ENTRETOISE ABSTANDSSTUECK SPACER JUEGO DISTANCIA DISTANZIALE
	79 03 055 020	02 DIAM 12	RONDELLE GROWER GROWERSCHEIBE SPRING WASHER ARANDELA RONDELLA GROWER
10	79 03 232 019	02 DIAM 12X1,75	ECROU HEXAGONAL SECHSKANTMUTTER HEXAGONAL NUT TUERCA DADO ESAGONALE
			<b>XT</b>
51	95 623 251	02 1 POS -CAD	BLOC OPTIQUE LEUCHTEINHEIT HEADLIGHT BLOQUE OPTICO BLOCCO OTTICO

.../...

15/02/91  
1117 05-5410-10  
PAGE : 2  
D15 ↓

**ECLAIRAGE AVANT - FIXATION**  
BELEUCHTUNG VORNE - BEFESTIGUNG  
FRONT LIGHTING - SECURING  
ILUMINACION DELANTERA - SUJECION  
ILLUMINAZION ANTERIORE - FISSAGGIO

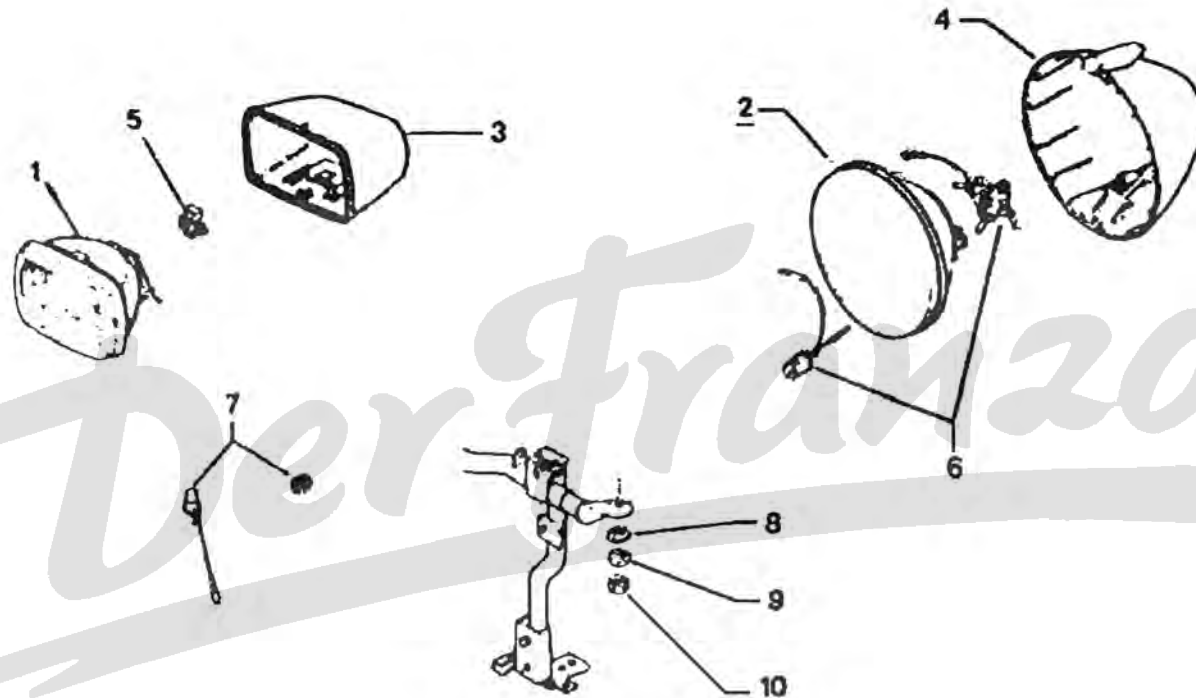

1117

[6/89]

05.5410 10

Z5410100

52

95 623 248

02 1 POS  
-CAD

BLOC OPTIQUE  
LEUCHTEINHEIT  
HEADLIGHT  
BLOQUE OPTICO  
BLOCCO OTTICO

15/02/91  
 1117 05-5410-20  
 PAGE : 1  
 D14 ↓

**ECLAIRAGE AVANT**  
**BELEUCHTUNG VORNE**  
**FRONT LIGHTING**  
**ILUMINACION DELANTERA**  
**ILLUMINAZIONE ANTERIORE**

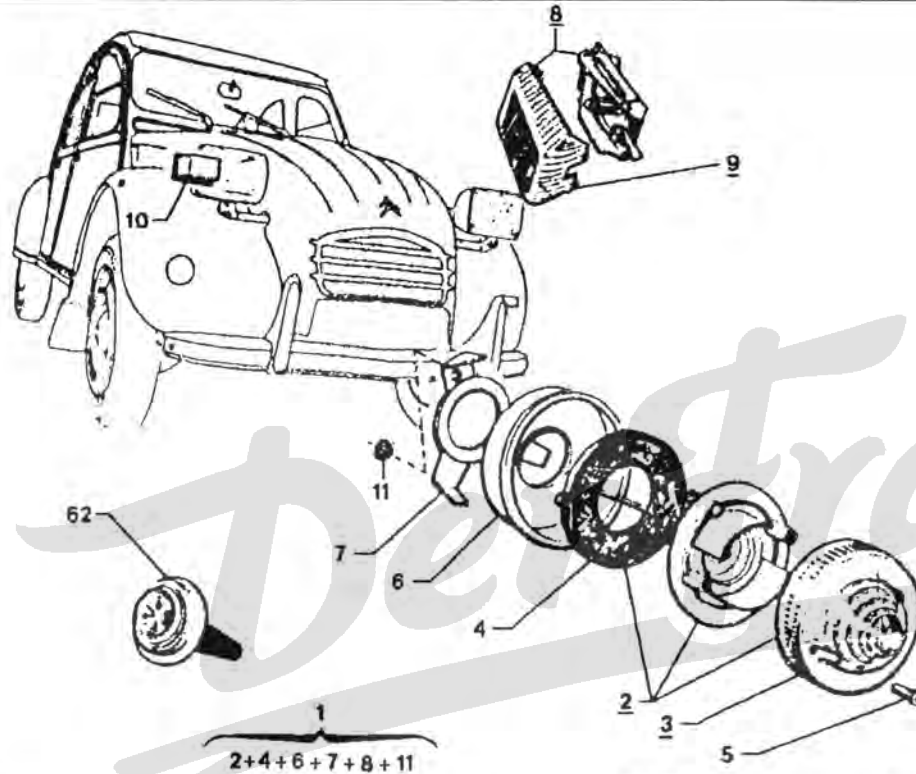

1117

[6/89]

5-541-20

Z5410200

01	95 611 064	01 G- 'PAM'	FEU AV GAUCHE LEUCHE V.L FRONT LIGHT LH PILOTO AV FANALE ANT.SIN.
	95 611 065	01 'PAM'	FEU AV DROIT LEUCHE V.R FRONT LIGHT RH PILOTO AV FANALE ANT.DES.

02	AZ 575 201 A	02	INDIC-DIRECTION AXO	FEU AV LEUCHE VORN FRONT LIGHT PILOTO FANALE ANTERIOR
03	AZ 575 250 A	02	INDIC-DIRECTION AXO	TRANSPARENT AV KAPPE TRANSPAR. FRT. LIGHT LENS TRANSPARENCIA COPERCHIO
04	DJF 544 144 A NFP	02		JOINT DE FEU AV FRONTLICHTDICHT FRT LIGHT SEAL JUNTA PILOTO AV GUARNIZIONE FAN
05	AY 575 76 A	04		VIS SCHRAUBE LENS FIX SCREW TORNILLO VITE COPERCHIO
06	95 563 284*136	01 D- AXO		SUPPORT FEUX LEUCHTENHALTER LIGHT BRACKET SOPORTE PILOTOS SUPPORTO
	95 563 283*200	01 G -CHARLESTON		-
	95 563 284*200	01 D- -CHARLESTON		-
07	AZ 575 211 A	01 G- INDIC-DIRECTION -G AXO		ETRIER, FEU AV BUEGEL LIGHT HOLDER ESTRIBO STAFFA
	AZ 575 212 A	01 D- INDIC-DIRECTION AXO		-
08	AZ 545 03 A	01	ECLAIREUR INTERIEUR SEIMA	PLAFONNIER INNENLEUCHE INTERIOR LAMP PLAFON PLAFONIERA
	95 492 822	01	COFFRE SEIMA	ECLAIREUR LEUCHE TRUNK LAMP ALUMBRADO LUCE

.../...



15/02/91  
 1117 05-5410-20  
 PAGE : 2  
 D13 ↓

**ECLAIRAGE AVANT**  
**BELEUCHTUNG VORNE**  
**FRONT LIGHTING**  
**ILUMINACION DELANTERA**  
**ILLUMINAZIONE ANTERIORE**

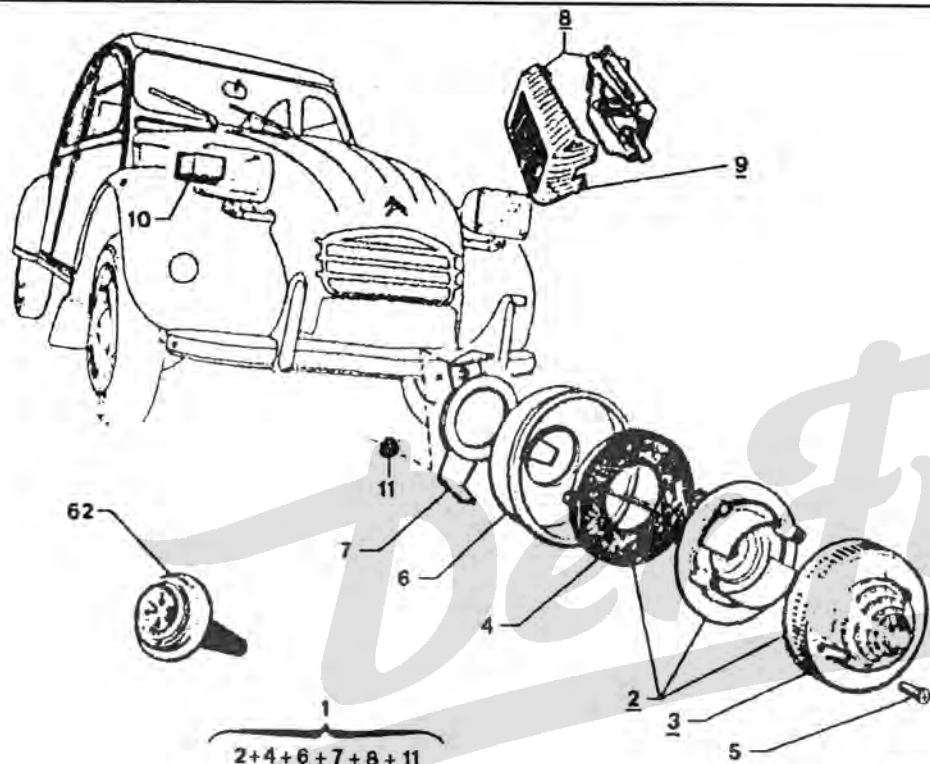

1117

2+4+6+7+8+11

[6/89]

5-541-20

Z5410200

09	AZ 545 4 A RP AZ54503A	01 SEIMA	TRANSPARENT KAPPE TRANSPAR. INT LIGHT LENS TRANSPARENCIA COPERCHIO
	5 484 787	01 SEIMA	.
10	75 429 672	01 CARTIER	CENTRAL CLIGNOT BLINKRELAIS FLASHER UNIT CENTRAL LAMPADA CENTRAL

11	79 03 056 005	04	DIAM 5,3X9,4	RONDELLE A DENT ZAHNSCHEIBE SPRING WASHER ARANDELA RONDELLA DENTAT
			<b>XT</b>	
52	AZ 575 202 A NFP	02	INDIC-DIRECTION -(I)	FEU AV LEUCHTE VORN FRONT LIGHT PILOTO FANALE ANTERIOR
53	AZ 575 251 A	02	-(I)	TRANSPARENT AV KAPPE TRANSPAR. FRT LIGHT LENS TRANSPARENCIA COPERCHIO
58	95 492 822	01	COFFRE SEIMA -CAD	ECLAIREUR LEUCHTE TRUNK LAMP ALUMBRADO LUCE
59	5 484 787	01	SEIMA -CAD	TRANSPARENT KAPPE TRANSPAR. INT LIGHT LENS TRANSPARENCIA COPERCHIO
62	5 402 230	02	ORANGE -(I) -(DK) 01/81 ▶ -(N) 1516 ▶	FEU LATERAL SEITENLEUCHTE SIDE LIGHT PILOTO LATERAL FANALE LATERALE
63	5 403 627	02	-(DK) 06/80 ▶ -(I) 01/81 ▶ -(N) 1516 ▶	SUPPORT FEUX LEUCHTENHALTER LIGHT BRACKET SOPORTE PILOTOS SUPPORTO

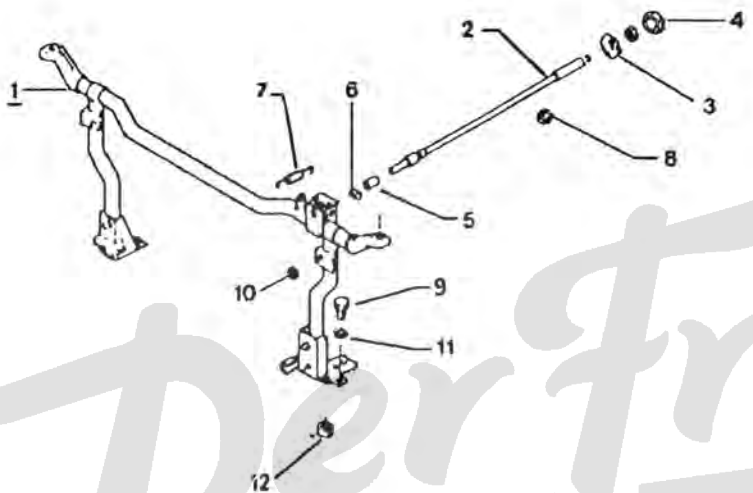
15/02/91 1117 05-5416-10 PAGE : 1 D12 ↓		<b>BARRE DE PHARES - COMMANDE</b> HALTER - BETAETIGUNG BRACKET-LIGHTING SOPORTE-MANDO SUPPORTO-COMANDO		03	AZ 644 79	01	BOUTON DE CDE BET.-KNOPF CONTROL BUTTON BOTON MANDO BOTTONE COMANDO
 <p>1117 [6/89] 05.5416 10 Z5416100</p>		04	ZC 9804 104 U	01	CC	-	
		05	AZ 541 85	01	8X10X27	ENTRETOISE ABSTANDSSTUECK SPACER JUEGO DISTANCIA DIZANZIALE	
		06	A 541 86	01	16X20-DIAM 10X1,50	ECROU REGLAGE MUTTER ADJUSTING NUT TUERCA DADO	
		07	AK 541 51	01		RESSORT FEDER FIXING SPRING RESORTE MOLLA	
		08	21 061 009	01	8X18X4 CAOUTCHOUC	OUILLET GUMMIOESE RUBBER GROMMET PASACABLE OCCHIELLO	
		09	79 03 201 129	06	DIAM 5X0,80-12	VIS TH SCHRAUBE CAPSCREW TORNILLO TH VITE	
		10	A 541 75	02	7,25X12X0,5	BOUTON REGLAGE EINSTELLKNOPF ADJUST BUTTON BOTON REGULADOR BOTTONE REGOLAZ	
		11	79 03 056 012	02	CR 7,3X12	RONDELLE GROWER GROWERSCHEIBE SPRING WASHER ARANDELA RONDELLA GROWER	
		12	79 03 032 036	02	HE 7X1,00-5,5	ECROU MUTTER NUT TUERCA DADO	
		01	95 542 057 RP 95594201	01		SUPPORT OPTIQUE HALTER BRACKET SOPORTE SUPPORTO	
		02	AK 541 7	01		CDE REGLAGE BETAETIGUNG ADJUSTM CONTROL MANDO REGLAJE COMANDO	

5/02/91  
 117 05-5416-10  
 AGE : 2  
 11 ↓

**BARRE DE PHARES - COMMANDE**  
 HALTER - BETAETIGUNG  
 BRACKET-LIGHTING  
 SOPORTE-MANDO  
 SUPPORTO-COMANDO

60	96 075 895	01	MANUELLE -(D)	CDE REGLAGE BETAETIGUNG ADJUSTM CONTROL MANDO REGLAJE COMANDO
61	96 075 896	01	REGLAGE PROJECTEURS -(D)	TIGE DE CDE BETAETIG.STANGE CONTROL ROD VARILLA MANDO ASTA COMANDO

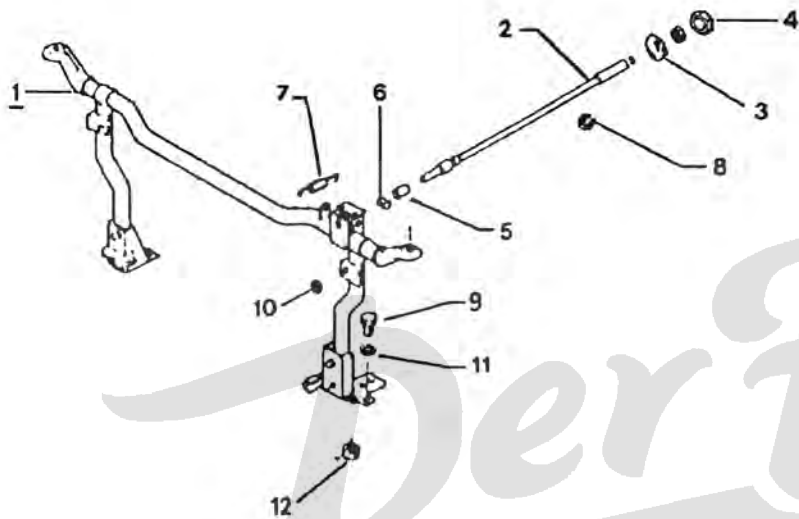

*Der Franzose*

6/89

05.5416 10

Z5416100

**XT**

5 461 895

01 -CAD

SUPPORT OPTIQUE  
 HALTER  
 BRACKET  
 SOPORTE  
 SUPPORTO

15/02/91  
 1117 05-5440-10  
 PAGE : 1  
 D10 ↓

**ECLAIRAGE ARRIERE**  
 BELEUCHTUNG HINTEN  
 REAR LIGHTING  
 ILUMINACION TRASERA  
 ILLUMINAZIONE POSTERIORE

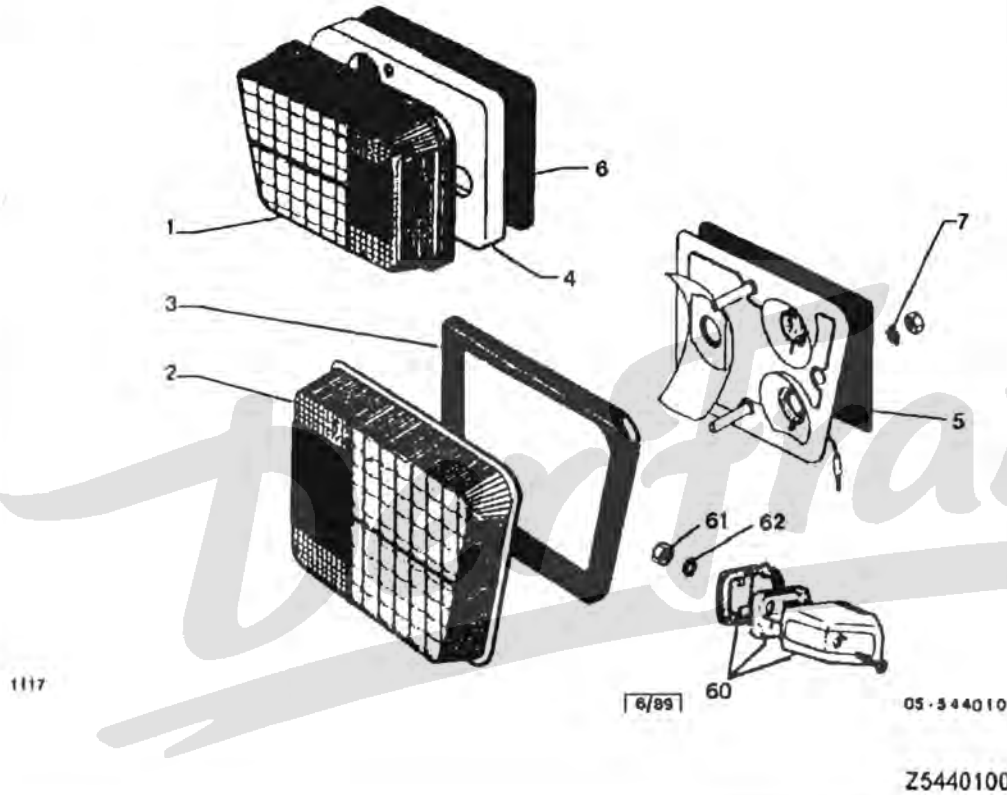

1117

[6/89]

05-544010

Z5440100

- REP: 11 EST NFP

01	75 515 736	01	ALTISSIMO	FEU AR DROIT RUECKLEUCHTE R. TAIL-LIGHT RH PILOTO AR FANALE POS.DES.
02	5 433 527	01	G- SEIMA	TRANSPARENT AR KAPPE TRANSPAR. TAIL-LIGHT LENS TRANSPARENCIA COPERCHIO
	5 433 528	01	D- D-SEIMA	-
	75 515 737	01	G- ALTISSIMO	-
	75 515 738	01	D- ALTISSIMO	-
03	AM 544 23 A NFP	01	G SEIMA	JOINT DE FEU AR R-LEUCHT-DICHT. TAIL-LIGHT SEAL JUNTA PILOTO AR GUARNIZIONE FAN
	75 515 739	02	D-G- ALTISSIMO	-
04	95 563 394 200	01	G -CHARLESTON	SUPPORT FEU AR LEUCHTENHALTER RR LIGHT BRACKET SOP. PILOTO AR SUPPORTO FAN.PO
	95 563 395 200	01	D- -CHARLESTON	-
05	AZ 544 187 A	02		PLATINE FEU AR LICHTPLATINE TAIL LIGHT PLAT PLACA CONEXIONE PIASTRA FANALE
06	96 995 648	02		JOINT DE FEU AR R-LEUCHT-DICHT. TAIL-LIGHT SEAL JUNTA PILOTO AR GUARNIZIONE FAN
07	79 03 056 005	06	DIAM 5,3X9,4	RONDELLE A DENT ZAHNSCHEIBE SPRING WASHER ARANDELA RONDELLA DENTAT
01	5 433 521	01	SEIMA	FEU AR GAUCHE RUECKLEUCHTE L. TAIL-LIGHT LH PILOTO FANALE POS.SIN.
	75 515 735	01	ALTISSIMO	-
	5 433 522	01	SEIMA	FEU AR DROIT RUECKLEUCHTE R. TAIL-LIGHT RH PILOTO AR FANALE POS.DES.

.../...

15/02/91  
 1117 05-5440-10  
 PAGE : 2  
 D09 ↓

**ECLAIRAGE ARRIERE**  
 BELEUCHTUNG HINTEN  
 REAR LIGHTING  
 ILUMINACION TRASERA  
 ILLUMINAZIONE POSTERIORE

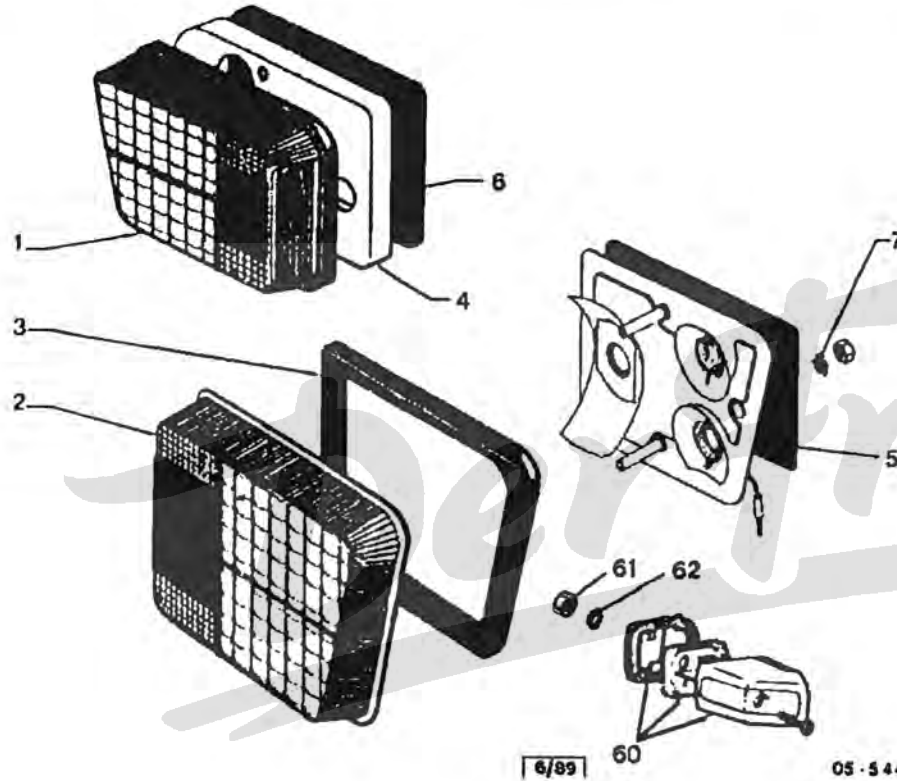

1117

6/89

60

05-544010

Z5440100

60	5 407 388	01	D- SEIMA -(CH)	VOILE VORHANG VEIL VELA VELO
61	79 03 032 006	04	DIAM 5X0,80 -(CH)	ECROU MUTTER NUT TUERCA DADO
62	79 03 056 003	08	DIAM 4,2 X 8 -(CH)	RONDELLE A DENT ZAHNSCHEIBE SPRING WASHER ARANDELA RONDELLA DENTAT

**XT**

60 5 407 385

01 G.  
SEIMA  
-(CH)

ECLAIREUR  
 LEUCHTE  
 LICEN PLAT LAMP  
 ALUMBRADO  
 LUCE

15/02/91  
1117 05-5440-20  
PAGE : 1  
D08 ↓

**ECLAIRAGE ARRIERE**  
BELEUCHTUNG HINTEN  
REAR LIGHTING  
ILUMINACION TRASERA  
ILLUMINAZIONE POSTERIORE

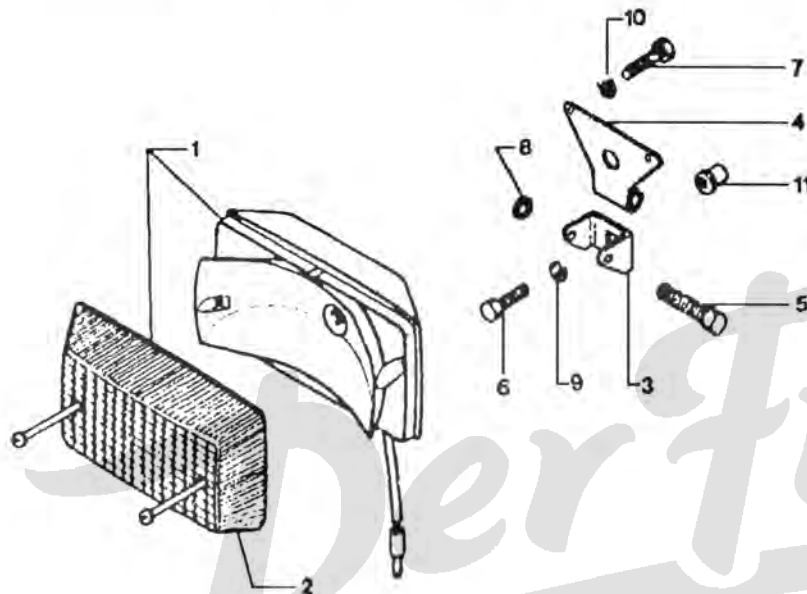

1115

[04/87]

5.544-20

Z5440200

03	5 488 773	01	25,3X13	PATTE HALTELASCHE SUPPORT LUG SOPORTE STAFFA
04	5 488 772	01	60X34	-
05	79 03 201 025	01	DIAM 6X1,00-35	VIS TH SCHRAUBE CAPSCREW TORNILLO TH VITE
06	79 03 001 708	01	DIAM 7X1,00-20	-
07	79 03 201 003	01	DIAM 4X0,70-12	-
08	79 03 056 008	01	DIAM 6,3X11	RONDELLE A DENT ZAHNSCHEIBE SPRING WASHER ARANDELA RONDELLA DENTAT
09	79 03 056 065	0	DIAM 7,2X20,4	-
10	79 03 056 003	01	DIAM 4,2 X 0	-
11	79 03 073 024	01	DIAM 10,5	BAGUE HALTERING GROMMET PASACABLES BOCCOLA
<b>XT</b>				
51	95 619 671	01	3493 ▶	FEU DE RECU RUECKFAHRLEUCHT REVERSE LIGHT PILOTO FANALE RETROMAR
52	95 562 574 NFP	01	FEU RECU 3493 ▶	TRANSPARENT AR KAPPE TRANSPAR. TAIL-LIGHT LENS TRANSPARENCIA COPERCHIO

01	5 491 308	01	-(B) -(GB)	FEU AR BROUILL. NEBELSCHLEUCH REAR FOG LAMP PILOTO AR FAN.NEBBIA POST
02	5 503 772 RP 5491308	01	FEU BROUILLARD -(B) -(GB)	TRANSPARENT AR KAPPE TRANSPAR. TAIL-LIGHT LENS TRANSPARENCIA COPERCHIO

**ESSUIE VITRE**  
SCHEIBENWISCHER  
WINDSCREEN WIPER  
LIMPIA-PARABRISAS  
TERGICRISTALLO

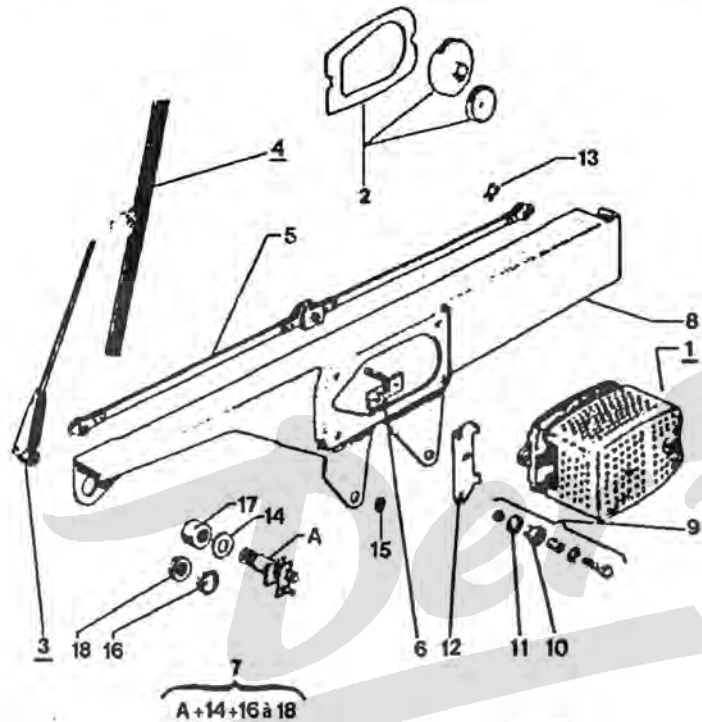

1117

A+14+16 à 18

[6/99]

05-5610 10

Z5610100

01	95 537 623	01	NU	▶ 05/80	MOT ES-VITRE AV MOTOR WIPER MOTOR MOTOR MOTORINO
	95 494 657	01		05/80 ▶ 1710	-
	95 570 978	01		1711 ▶	-
02	95 537 412 NFP	01	ENS	▶ 1710	ENS FIX PALIER BEF.-SATZ LAGER BEARING MOUNTG JUEGO FIX EJES INS.FISS.CUSCIN
03	95 596 594	02	NU		PORTE-BALAI WISCHERARM BLADE-HOLDER BRAZO LIMPIA BRACCIO TERGI
04	ZC 9865 982 U	02			BALAI ES-VITRE WISCHERBLATT WIPER BLADE ESCOBILLA SPAZZOLA
05	AZ 565 18	01	ENT 370	▶ 1710	BIELLE DE CDE BET.-STANGE CONTROL ROD BIELETA MANDO BIELLA DI COMAN
06	95 578 371 AZ 565 113	01 01	AVEC AXE	1711 ▶ ▶ 1710	MANIVELLE KURBEL WDW WIPER HANDL MANIVELA LEVA
07	95 578 372 AZ 565 5	01 02	AVEC AXE ENS	1711 ▶	SUPPRT CDE HALTER CONTROL BRACKET SOPORTE MANDO SUPPORTO
08	AZ 565 14 95 578 373	01 01	ENT 370	▶ 1710 1711 ▶	SUPPORT MOTEUR MOTORHALTER MOTOR BRACKET SOPORTE MOTOR SUPPORTO MOTORE
09	AZ 561 013 A	01	FIXATION	▶ 1710	ENS PIECES SATZ TEILE MOTOR PART KIT CONJUNTO PIEZAS INSIEME PEZZI
10	AM 561 69	04	6,5X11X14-FIXATION CAOUTCHOUC	▶ 1710	-

15/02/91  
1117 05-5610-10  
PAGE : 2  
D 06 ↓

**ESSUIE VITRE**  
SCHEIBENWISCHER  
WINDSCREEN WIPER  
LIMPIA-PARABRISAS  
TERGICRISTALLO

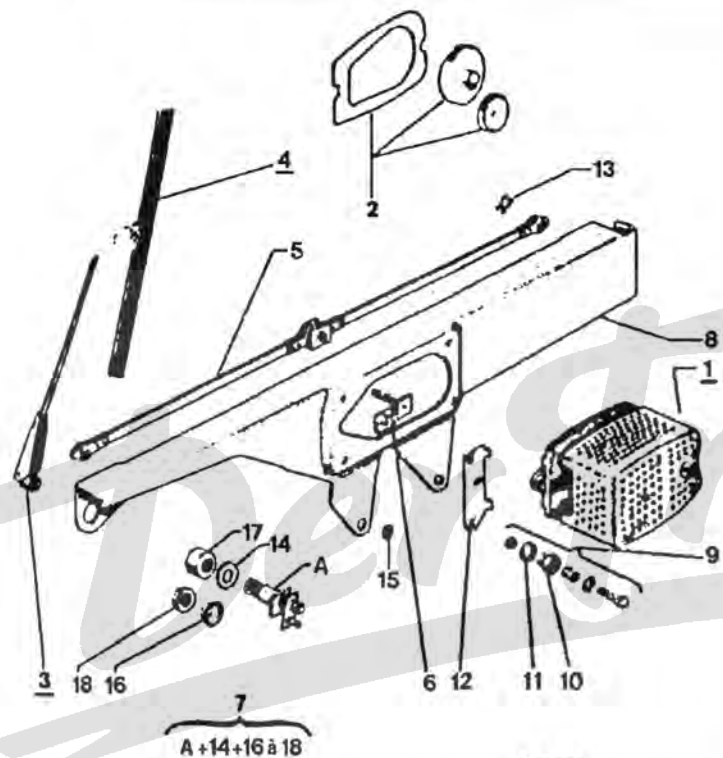

1117

A+14+16 à 18

6/89

05-5610 10

Z5610100

11	AM 561 79 RP AM56169	04 10X14X5-FIXATION CAOUTCHOUC	▶ 1710	ENS PIECES SATZ TEILE MOTOR PART KIT CONJUNTO PIEZAS INSIEME PEZZI
12	AZ 561 6	01 G-	▶ 1710	PATTE LASCHE MOT FIX BRACKET SOPORTE STAFFA
	AZ 561 6 A	01 D-		.

13	AZ 565 70	04		CLIP MAINTIEN HALTECLIPS RETAINING CLIP PERFIL FIJACION GRAFFETTA
14	AZ 565 49 A	02	16,2X24X0,5	RONDELLE D'AXE SCHEIBE SHAFT WASHER ARANDELA RONDELLA
15	79 03 056 005	02	DIAM 5,3X9,4	RONDELLE A DENT ZAHNSCHEIBE SPRING WASHER ARANDELA RONDELLA DENTAT
16	AZ 565 49	02		RONDELLE D'AXE SCHEIBE SHAFT WASHER ARANDELA RONDELLA
17	AZ 565 79	02	HE 16X1,00	ECROU HEXAGONAL SECHSKANTMUTTER HEXAGONAL NUT TUERCA DADO ESAGONALE
18	AM 565 94 RP 7920024376	02	HE 16X1,00	ECROU MUTTER NUT TUERCA DADO
51	AY 561 102 A	01	12 VOLTS-2 ALLURES -(S) ▶ 05/80 -(N) ▶ 05/80	MOT ES-VITRE AV MOTOR WIPER MOTOR MOTOR MOTORINO
	95 570 979	01	2 ALLURES -(N) 1711 ▶	.
53	5 475 533	01	-CAD	PORTE-BALAI WISCHERARM BLADE-HOLDER BRAZO LIMPIA BRACCIO TERGI

**XT**

.../...



15/02/91  
 1117 05-5610-10  
 PAGE : 3  
 D 05 ↓

**ESSUIE VITRE**  
**SCHEIBENWISCHER**  
**WINDSCREEN WIPER**  
**LIMPIA-PARABRISAS**  
**TERGICRISTALLO**

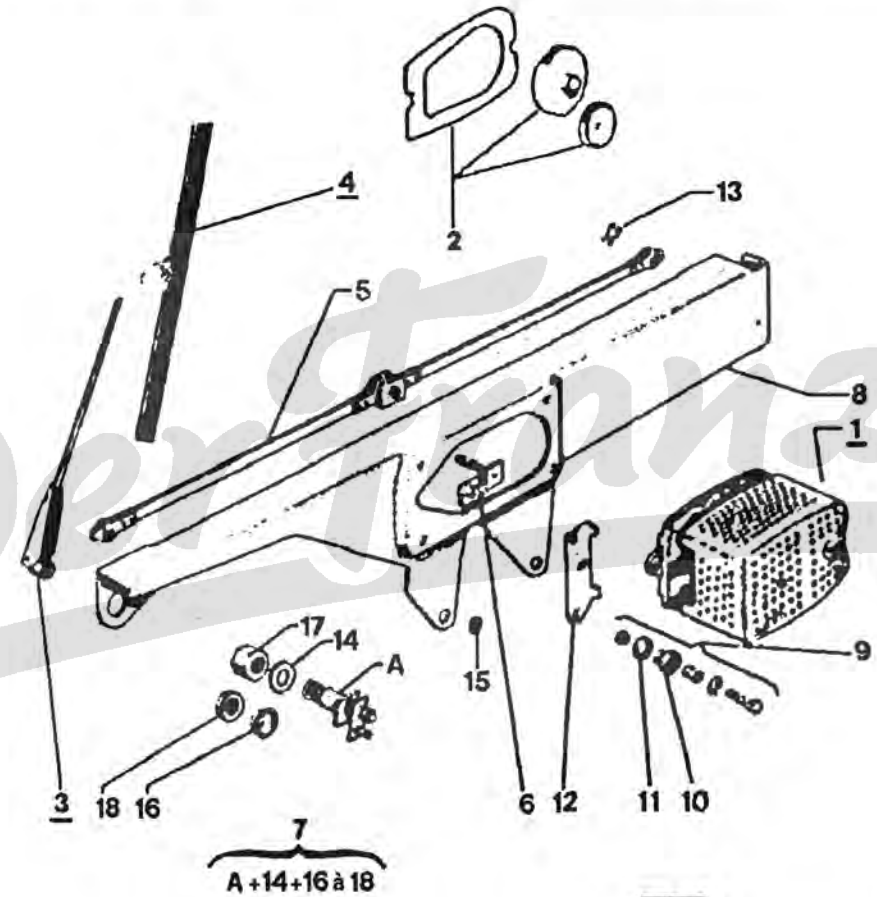

1117

A+14+16 à 18

6/89

05-5610 10

Z5610100

54	ZC 9875 261 U	02 LONG 230 -(J)	BALAI ES-VITRE WISCHERBLATT WIPER BLADE ESCOBILLA SPAZZOLA
----	---------------	---------------------	--

15/02/91  
 1117 05-5640-10  
 PAGE : 1  
 D04 ↓

LAVE VITRE  
 SCHEIBENWASCHANLAGE  
 WINDSCREEN WASHER  
 LAVA-CRISTAL  
 LAVACRISTALLO

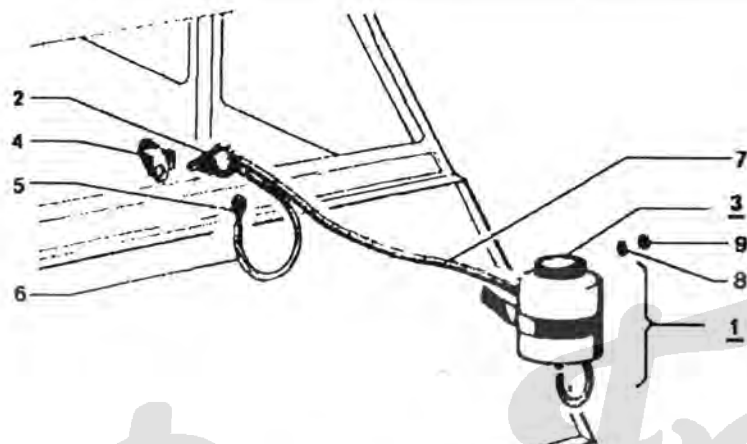

1117

8/89

05-5640 10

Z5640100

03	95 537 043	01		COUVERCLE DECKEL RESERVOIR CAP TAPA DEPOSITO COPERCHIO
	DS 564 67 B	01		BOUCHON STOPFEN PLUG TAPON DEPOSITO TAPPO
04	AZ 564 68	01	POMPE LAVE VITRE AV	PATTE HALTELASCHE SUPPORT LUG SOPORTE STAFFA
05	AZ 564 208 A	01	COMPLET	GICLEUR DUESE WDW WASHER JET SURTIDOR SPRUZZATORE
06	AY 564 55 RP 95499014	01	RESERVOIR A POMPE	TUYAU LEITUNG WDW WASHER PIPE TUBO LAVALUNAS TUBO LAVAVETRO
07	DX 564 103 Q, NFP	01	DE RESERVOIR	-
	95 636 046	01	LON 3100	-
08	79 03 058 027	02	DIAM 5X12X1,2	RONDILLE A DENT ZAHNSCHEIBE SPRING WASHER ARANDELA RONDELLA DENTAT
09	79 03 032 006	02	DIAM 5X0,80	ECROU MUTTER NUT TUERCA DADO
01	AZ 564 272 A	01	COMPLET	RESERVOIR BEHAELTER TANK DEPOSITO LAVAP. SERBATOIO
	95 537 044	01	NU	-
02	AZ 564 209 A	01	POMPE LAV.VITRE PUMPE WDW WASHER PUMP BOMBA DE LAVA POMPA	
51	95 558 958	01	AV-COMPLET (D)	RESERVOIR BEHAELTER TANK DEPOSITO LAVAP. SERBATOIO
			1515 ▶	.../...

**XT**

1515 ▶

.../...

15/02/91  
1117 05-5640-10  
PAGE : 2  
D03 ↓

LAVE VITRE  
SCHEIBENWASCHANLAGE  
WINDSCREEN WASHER  
LAVA-CRISTAL  
LAVACRISTALLO

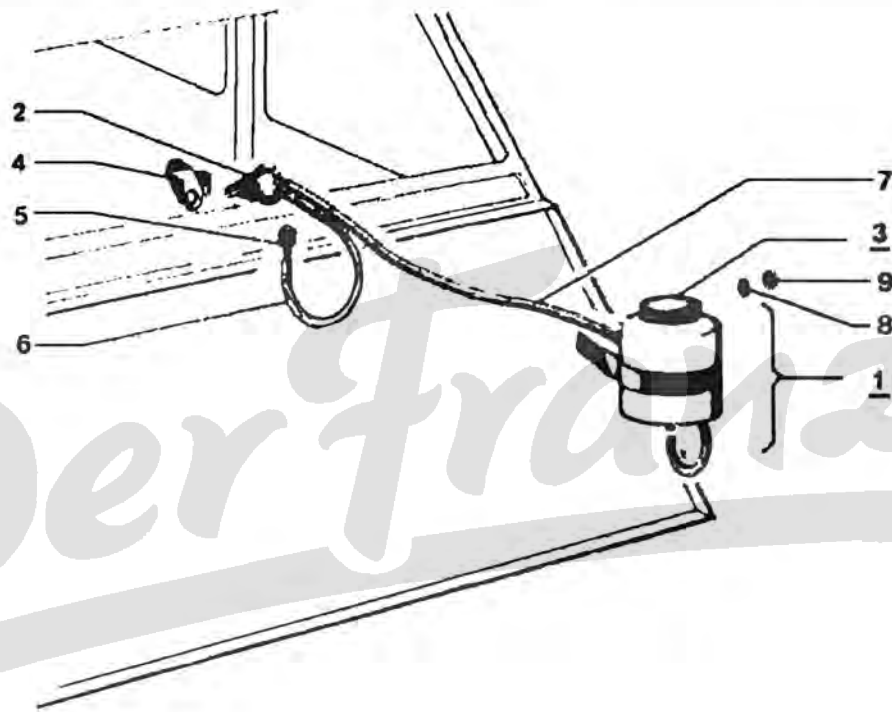

1117

6/89

05-5640 10

Z5640100

53

95 558 959  
NFP

01 -(D)

1515 ▶

BOUCHON  
STOPFEN  
PLUG  
TAPON DEPOSITO  
TAPPO

15/02/91  
1117 05-5710-10  
PAGE : 1  
D02 ↓

**AVERTISSEUR SONORE**  
HORN  
HORN  
INDICADOR SONORO  
AVVISATORE SONORO

01	95 493 264	01	KLAXON	05/80 ▶	<b>AVERTISSEUR</b> SIGNALHORN HORN BOCINA AVVISATORE
02	5 478 243	01			<b>SUPPORT</b> HALTER HORN BRACKET SOPORTE BOCINA SUPPORTO
03	25 242 009 RP 7903232017	01	DIAM 8X1.25-6,5		<b>ECROU HEXAGONAL</b> SECHSKANTMUTTER HEXAGONAL NUT TUERCA DADO ESAGONALE
04	79 03 056 012	01	CR 7,3X12		<b>RONDELLE GROWER</b> GROWERSCHEIBE SPRING WASHER ARANDELA RONDELLA GROWER
05	79 03 056 014	01	DIAM 8,5X14		<b>RONDELLE A DENT</b> ZAHNSCHEIBE SPRING WASHER ARANDELA RONDELLA DENTAT

**FUSIBLES MANOCONTACT CONTACTEUR**  
SICHERUNG - DRUCKSCHALTER  
FUSES-PRESSURE-SWITCHES  
FUSIBLES-MANOCONTACTOS-CONTACTORES  
FUSIBILI-MANOCONTATTI-CONTATTORI

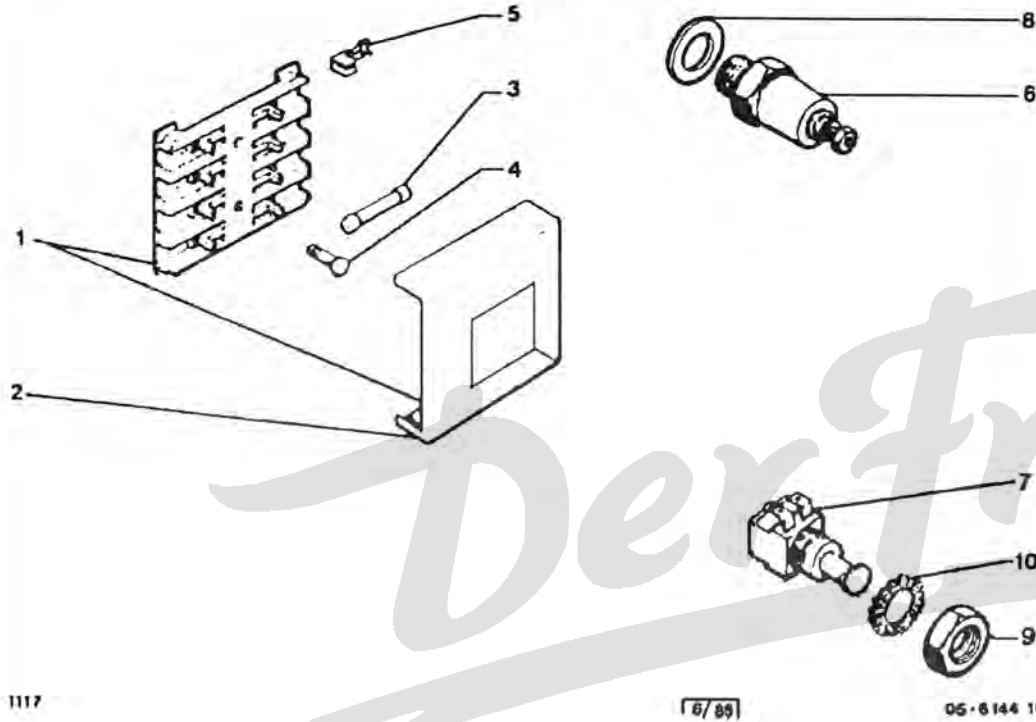

1117 [8/89] 05-6144 10 Z8144100

01	5 440 940	99		BOITE FUSIBLES SICHERUNGSKAST. FUSE-BOX CAJA FUSIBLES SCATOLA FUSIBIL
02	5 445 848	99	BOITIER	COUVERCLE DECKEL FUSE BOX COVER TAPA CAJA COPERCHIO

03	95 493 639	99	16A TEXTON	FUSIBLE SICHERUNG FUSE FUSIBLE FUSIBILE
	95 493 196	99	10A TEXTON	-
04	5 445 849	99		AGRAFE KLAMMER CLIP GRAPA AGRAFE
05	75 449 663	99		PORTE-FUSIBLE SICHERUNGHALTER FUSE-HOLDER PORTA FUSIBLE PORTAFUSIBILE
06	91 521 111	01	DIAM 12X1,50 3215 ▶	MANOCONTACT DRUCKSCHALTER OIL PRES SWITCH MANOCONTACTO MONOCONTATTO
07	5 422 483	01	TORRIX	CONTACTEUR STOP BREMSSCHALTER CONTACT SWITCH INTERRUP PARE CONTATTORE STOP
08	22 458 009	01	CU 12,2X17X1	JOINT DICHTUNG CIRCUIT SEAL JUNTA GUARNIZIONE
09	26 151 069	01	H 12X1,00	ECROU MUTTER NUT TUERCA DADO
10	79 03 056 020	01	CR-DIAM 12,5X22	RONDELLE A DENT ZAHNSCHEIBE SPRING WASHER ARANDELA RONDELLA DENTAT
11	5 486 988	01	EH 5 LANGUES	ETIQUETTE ETIKETT LABEL ETIQUETA RONDELLA DENTAT

15/02/91  
 1117 05-6144-10  
 PAGE : 2  
 E01 ↑

**FUSIBLES MANOCONTACT CONTACTEUR**  
 SICHERUNG - DRUCKSCHALTER  
 FUSES-PRESSURE-SWITCHES  
 FUSIBLES-MANOCONTACTOS-CONTACTORES  
 FUSIBILI-MANOCONTATTI-CONTATTORI

50

95 637 229

01

DIM TIP  
 -CAD

RESISTANCE  
 WIDERSTAND  
 RESISTANCE  
 RESISTENCIA  
 RESISTENZA

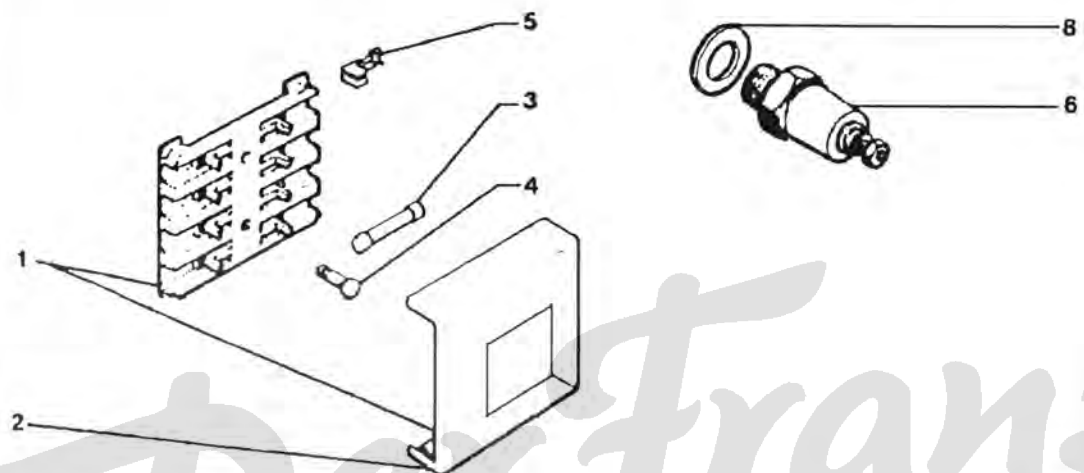

1117

6/89

05-6144 10

Z8144100

12	5 416 294	01	DE RECOL	CONTACTEUR FEUX SCHALTER CONTACT SWITCH CONTACTOR M/A CONTATT.FANALE
13	22 459 009	01	14,3X19X1 -2CV6	JOINT MANOCONT. DICHTUNG PRSS SWTCH SEAL JUNTA MANOCONT. GUARNIZIONE

UMERO	SOUS-GROUPE	REP	NUMERO	SOUS-GROUPE	REP	NUMERO	SOUS-GROUPE	REP	NUMERO	SOUS-GROUPE	REP
402 230	05-5410-20	82	5 488 988	05-6144-10	11	75 491 742	05-5213-10	09	95 596 594		03
403 627		63	5 488 772	05-5440-20	04	75 492 223		15	95 597 848	05-5213-20	10
407 093	05-5121-10	08	5 488 773		03	75 515 735	05-5440-10	01		05-5213-10	60
407 385	05-5440-10	60	5 489 145	05-5110-10	60	75 515 736		01	95 611 064	05-5410-20	01
407 388		60	5 489 146		60	75 515 737		02	95 611 065		01
412 142	05-5121-10	05	5 489 489	05-5121-10	18	75 515 738		02	95 619 671	05-5440-20	51
412 143		07	5 490 332	05-5213-10	55	75 515 739		03	95 623 227	05-5410-10	03
412 276		03	5 490 423		71	75 518 873	05-5213-10	03	95 623 228		04
412 809		09	5 490 893	05-5213-20	01	75 522 250	05-5110-10	51	95 623 247		02
413 594	05-5213-20	17	5 491 054		05	75 525 042	05-5213-10	72	95 623 248		52
413 895		11	5 491 280		06	75 528 522	05-5121-10	10	95 623 249		05
	05-5213-10	11		05-5213-10	06	91 521 111	05-6144-10	06	95 623 250		01
414 284	05-5213-20	51	5 491 308	05-5440-20	01	95 492 822	05-5410-20	08	95 623 251		51
416 294	05-6144-10	12	5 491 384	05-5213-10	10			58	95 623 273		07
420 487	05-5121-10	02	5 491 519	05-5213-20	05	95 493 196	05-6144-10	03	95 631 885	05-5213-20	03
420 488		10	5 503 772	05-5440-20	02	95 493 264	05-5710-10	01	95 631 999	05-5110-10	50
422 483	05-6144-10	07	5 505 569	05-5213-10	01	95 493 839	05-6144-10	03	95 636 046	05-5640-10	07
422 618	05-5410-10	05	5 505 727	05-5410-10	01	95 493 838	05-5213-10	05	95 637 229	05-6144-10	50
427 285	05-5213-20	07	5 508 653	05-5213-10	02		05-5213-20	07	95 637 254	05-5110-10	01
433 521	05-5440-10	01	5 509 285		02	95 494 657	05-5810-10	01	95 637 255	05-5110-11	01
433 522		01	21 061 009	05-5416-10	08			01	95 637 257	05-5110-10	02
433 527		02		05-5121-10	11	95 494 957	05-5213-20	07	95 637 258		52
433 528		02	21 062 008		11	95 495 349		51		05-5110-11	02
440 875	05-5213-10	14	21 063 009		11	95 505 725	05-5410-10	03	96 016 831	05-5110-10	01
440 940	05-6144-10	01	21 064 009		11	95 537 043	05-5640-10	02	96 016 832		51
442 804	05-5213-10	03	21 065 009		11	95 537 044		01	96 075 818		51
443 127	05-5410-10	08	22 458 009	05-6144-10	08	95 537 412	05-5610-10	02	96 075 895	05-5416-10	60
443 554	05-5310-10	09	22 459 009		13	95 537 623		01	96 075 896		61
444 684		08	24 708 009	05-5213-20	13	95 542 057	05-5416-10	01	98 995 648	05-5440-10	06
445 848	05-6144-10	02	25 242 009	05-5710-10	03	95 543 808	05-5110-11	01	96 995 683	05-5121-10	04
445 849		04	25 907 009	05-5127-20	03	95 544 487	05-5121-10	08	5 500 852*706	05-5213-20	13
457 472	05-5121-10	14	25 908 009		03	95 550 633	05-5110-10	01	A 541 75	05-5416-10	10
461 150	05-5110-11	03	25 917 009		04	95 550 634		51	A 541 86		06
	05-5110-10	03	25 919 009		06	95 550 835		51	AK 521 3 B	05-5213-20	08
461 895	05-5416-10	51	25 926 009		05	95 550 836		01		05-5213-10	13
465 935	05-5121-10	13	26 101 009		81	95 558 958	05-5640-10	51	AK 541 51	05-5416-10	07
467 554	05-5310-10	04	26 108 009		71	95 558 959		53	AK 541 7		02
469 954	05-5213-10	04	26 109 009		02	95 562 574	05-5440-20	52	AM 521 282 A	05-5213-10	63
475 533	05-5810-10	53	26 142 289	05-5121-10	18	95 564 177	05-5110-10	01		05-5213-20	58
475 738	05-5213-20	14		05-5213-10	12	95 564 178		51	AM 531 72	05-5310-10	06
478 243	05-5710-10	02		05-5213-20	12	95 564 179		01	AM 544 23 A	05-5440-10	03
481 270	05-5213-10	06	26 145 429	05-5121-10	04	95 564 180	05-5110-11	01	AM 561 69	05-5610-10	10
484 787	05-5410-20	59	26 145 449		04	95 567 394	05-5213-20	03	AM 561 79		11
		09	26 146 469		15	95 570 978	05-5610-10	01	AM 565 94		18
486 253	05-5110-10	55	26 151 069	05-6144-10	09			51	AY 511 72	05-5121-10	17
496 487		01	26 198 639	05-5121-10	17	95 570 979		51	AY 522 273 A	05-5213-20	59
486 493		01	75 412 806	05-5213-20	11	95 575 409	05-5110-11	01			07
486 513		02		05-5213-10	11	95 576 540	05-5410-10	04	AY 581 102 A	05-5610-10	51
	05-5110-11	02	75 429 672	05-5410-20	10	95 578 371	05-5810-10	05	AY 564 55	05-5640-10	06
486 519	05-5110-10	52	75 444 179	05-5310-10	07	95 578 372		08	AY 575 76 A	05-5410-20	05
486 524		50	75 449 663	05-6144-10	05	95 578 373		08	AZ 512 3	05-5121-10	02

B04 ↑

INDEX

Catalogue 1117

NUMERO	SOUS-GROUPE	REP	NUMERO	SOUS-GROUPE	REP	NUMERO	SOUS-GROUPE	REP
AZ 512 4		03	ZC 9865 452 U		51			
AZ 521 20	05-5213-20	02	ZC 9865 474 U	05-5310-10	01			
AZ 522 222 A		06	ZC 9865 982 U	05-5610-10	04			
AZ 531 87 C	05-5310-10	03	ZC 9875 261 U		54			
AZ 541 85	05-5416-10	05	ZC 8875 631 U	05-5127-20	01			
AZ 544 187 A	05-5440-10	05	ZD 9232 300 U	05-5310-10	10			
AZ 545 03 A	05-5410-20	08	79 03 001 708	05-5440-20	06			
AZ 545 4 A		09	79 03 032 006	05-5440-10	61			
AZ 561 013 A	05-5610-10	09		05-5640-10	09			
AZ 561 6		12	79 03 032 036	05-5416-10	12			
AZ 561 6 A		12	79 03 055 020	05-5410-10	08			
AZ 564 208 A	05-5640-10	05	79 03 056 003	05-5440-10	62			
AZ 564 209 A		02		05-5440-20	10			
AZ 564 272 A		01	79 03 056 005	05-5440-10	07			
AZ 564 88		04		05-5610-10	15			
AZ 565 113	05-5610-10	06		05-5410-20	11			
AZ 565 14		08	79 03 056 008	05-5440-20	08			
AZ 565 18		05	79 03 056 012	05-5710-10	04			
AZ 565 49		16		05-5418-10	11			
AZ 565 49 A		14	79 03 056 014	05-5710-10	05			
AZ 565 5		07	79 03 056 020	05-6144-10	10			
AZ 565 70		13	79 03 056 065	05-5440-20	09			
AZ 565 79		17	79 03 057 066	05-5213-20	16			
AZ 575 201 A	05-5410-20	02	79 03 058 027	05-5640-10	08			
AZ 575 202 A		52	79 03 073 024	05-5440-20	11			
AZ 575 211 A		07	79 03 074 999	05-5213-20	59			
AZ 575 212 A		07	79 03 097 996	05-5121-10	19			
AZ 575 250 A		03	79 03 097 997		19			
AZ 575 251 A		53	79 03 201 003	05-5440-20	07			
AZ 644 79	05-5416-10	03	79 03 201 025		05			
AZU 531 91	05-5310-10	02	79 03 201 129	05-5416-10	09			
D 743 91		05	79 03 201 130	05-5310-10	11			
DJF 544 144 A	05-5410-20	04	79 03 232 019	05-5410-10	10			
DS 564 67 B	05-5640-10	03	95 563 283'200	05-5410-20	06			
DX 511 151 A	05-5121-10	12	95 563 284'136		06			
DX 511 99		06	95 563 284'200		06			
DX 564 103 D	05-5640-10	07	95 563 394'200	05-5440-10	04			
GX 41 400 01A	05-5213-20	59	95 563 395'200		04			
	05-5213-10	70			04			
GX 41 402 01A		70						
	05-5213-20	59						
GX 41 404 01A		09						
	05-5213-10	07						
HY 522 01 B		08						
	05-5213-20	04						
ZC 9003 732 U	05-5121-10	01						
ZC 9003 733 U		01						
ZC 9614 540 U		04						
ZC 9614 541 U		04						
ZC 9804 104 U	05-5416-10	04						
ZC 9865 189 U	05-5127-20	02						



15/02/91 1117 <b>TABLEAU DES VUES</b> <b>AUFSTELLUNG DER BILDER</b> <b>TABLE OF PICTURE</b> B01 ↑ <b>TABLA DE VISTAS</b> <b>TABELLA DELLE VEDUTE</b>	<b>GRUPE</b> <b>GROUP</b> <b>GROUP 06</b> <b>GRUPO</b> <b>GRUPPO</b>		<b>PARE-CHOC AVANT</b> <b>VORDERE STOSSTANGE</b> <b>FRONT BUMPER</b> <b>PARECHOQUES DELANTEROS</b> <b>PARAURTÌ ANTERIORI</b>	6171-10	D12 D11
<b>SOUS-GROUPE</b> <b>UNTERGRUPPE</b> <b>SUBGROUP</b> <b>SUBGRUPO</b> <b>SOTTOGRUPPO</b>	<b>NUMERO</b> <b>NUMMER</b> <b>NUMBER</b> <b>NUMERO</b> <b>NUMERO</b>	<b>VUE</b> <b>BILD</b> <b>PICTURE</b> <b>VISTA</b> <b>VEDUTA</b>	<b>PARE-CHOC ARRIERE</b> <b>HINTERE STOSSTANGE</b> <b>REAR BUMPER</b> <b>PARECHOQUES TRASEROS</b> <b>PARAURTÌ POSTERIORE</b>	6172-20	D10 D09
<b>SUSPENSION MOTEUR - BOITE DE VITESSES</b> <b>MOTORAUFHAENGUNG</b> <b>ENGINE BRACKET</b> <b>SUSPENSION MOTOR</b> <b>SOSPENSIONE MOTORE</b>	1330-10	C02 C03	<b>DEGIVRAGE - CHAUFFAGE</b> <b>HEIZUNG LUEFTUNG</b> <b>HEATING VENTILATION</b> <b>CALEFACCION AIREACION</b> <b>RISCALDAMENTO AERAZIONE</b>	6424-10	D08 D07
<b>POMPE A ESSENCE ET CANALISATIONS</b> <b>KRAFTSTOFFLEIGUNG</b> <b>FUEL PIPING</b> <b>CANALIZACION DE GAZOLINA</b> <b>CANALIZZAZIONE DELLA BENZINA</b>	1730-10	C04 C05	<b>COMMANDE VOLETS DE CHAUFFAGE - DEGIVRAGE</b> <b>HEIZ UND VELUEFTUNGSBETAETIGUNG-KLAPPEN</b> <b>HEATING VENTILATION CONTROLS AND SHUTTER</b> <b>MANDO DE VENTANILLAS DE CALEFACCION</b> <b>COMANDO E SPORTELLI RISCALDAMENTO AERAZI</b>	6430-20	D06 D05 D04
<b>RESERVOIR CARBURANT</b> <b>KRAFTSTOFFTANK</b> <b>FUEL TANK</b> <b>DEPOSITO DE CARBURANTE</b> <b>SERBATOIO DELLA CARBURANTE</b>	1750-10 1750-11	C06 C07 C08 C09	<b>AERATION</b> <b>LUEFTUNG</b> <b>VENTILATION</b> <b>AERACION</b> <b>AERAZIONE</b>	6441-10	D03 D02
• (D) <b>ECHAPPEMENT AVANT</b> <b>AUSPUFFANLAGE VORN</b> <b>EXHAUST FRONT</b> <b>ESCAPE DELANTERO</b> <b>SCARICO ANTERIORE</b>	1830-10	C10 C11	<b>PLATE-FORME</b> <b>RAHMEN</b> <b>PLATFORM</b> <b>PLATAFORMA</b> <b>PIATTAFORMA</b>	7210-10	D01 E01
<b>ECHAPPEMENT ARRIERE</b> <b>AUSPUFFANLAGE HINTEN</b> <b>EXHAUST REAR PART</b> <b>ESCAPE TRAS PARTE TRASERA</b> <b>SCERICO POST PARTE POSTERIORE</b>	1848-20	C12 C13 C14	<b>PLATE-FORME - SOLUTION REPARATION</b> <b>RAHMEN - REPARATURTEILE</b> <b>PLATFORM - REPAIR PARTS</b> <b>PLATAFORMA - SOLUCION REPARACION</b> <b>PIATTAFORMA - SOLUZIONE RIPARAZIONE</b>	7210-20	E02 E03
<b>REFROIDISSEMENT MOTEUR TOLE-VENTILATEUR</b> <b>KUEHLUNG - GEBLAESERAD - LUFTFUEHRUNG</b> <b>COOLING - FAN - AIR INTAKE</b> <b>REFRIGERACION COLECTOR DE AIRE-VENTIL</b> <b>RAFFREDDAMENTO CONVOGLIATORE DELL ARIA</b>	2421-10	C15 D15 D14 D13			

**SUSPENSION MOTEUR - BOITE DE VITESSES**  
MOTORAUFHAENGUNG  
ENGINE BRACKET  
SUSPENSION MOTOR  
SOSPENSIONE MOTORE

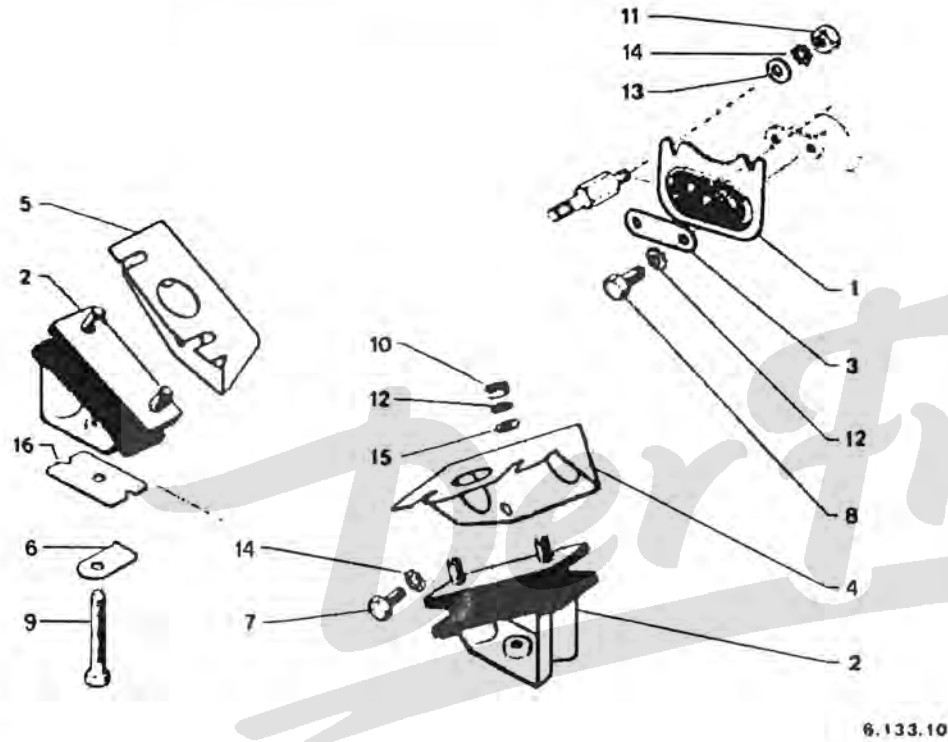

1114

6.133.10

Z1330100

01	AM 133 1	01	AR	SUPPORT MOTEUR MOTORHALTERUNG MOUNTING BRACKET SOPORTE MOTOR SUPPORTO
02	95 496 097	02	AV	2123 ▶ .
03	95 602 696	01	AR	PLAQUETTE ARRET ANHALTEPLAETTCH STOP PLATE PLAQUETA PIASTRA ARRESTO

04	75 506 357	01	G- G-AV	EQUERRE WINKEL SUSPENS BRACKET ESCUADRA SQUADRA
05	75 506 358	01	D- D-AV	.
06	79 03 058 043	02	DIAM 10.2X27 E 1.6	RONDELLE A DENT ZAHNSCHEIBE SPRING WASHER ARANDELA RONDELLA DENTAT
07	75 520 510	04	DIAM 10X1.25	VIS SCHRAUBE SUSPENSN SCREW TORNILLO VITE FISSAGGIO
08	79 03 001 603	02	DIAM 7X1.00-40	VIS TH SCHRAUBE CAPSCREW TORNILLO TH VITE
09	79 03 201 173	02	TH 10X150 LON 50	VIS FIX SUPPORT HALT.EEF.SCHRAU SUPPORT SCREW TORNILLO SOPORT VITE SUPPORTO
10	79 03 032 036	04	HE 7X1.00-5.5	ECROU MUTTER NUT TUERCA DADO
11	79 03 032 252 RP 7903232018	02	HE 10X1,50	ECROU HEXAGONAL SECHSKANTMUTTER HEXAGONAL NUT TUERCA DADO ESAGONALE
12	79 03 056 012	06	CR 7.3X12	RONDELLE GROWER GROWERSCHEIBE SPRING WASHER ARANDELA RONDELLA GROWER
13	79 03 053 394	02	DIAM: 10 X 20 X 2	RONDELLE PLATE FLACHSCHEIBE PLAIN WASHER ARANDELA PLANA RONDELLA PIATTA

13/02/91  
 1117 06-1330-10  
 PAGE : 2  
 C03 ↑

**SUSPENSION MOTEUR - BOITE DE VITESSES**  
 MOTORAUFHAENGUNG  
 ENGINE BRACKET  
 SUSPENSION MOTOR  
 SOSPENSIONE MOTORE

50

5 475 156

02

-(GB) -ATMOSPHERE POUSSIERES  
 -GA -ARMEE

CALE DE REGLAGE  
 EINSTELLBEILAGE  
 ADJUSTMENT SHIM  
 CALA REGLAJE  
 SPESSORE REGOL.

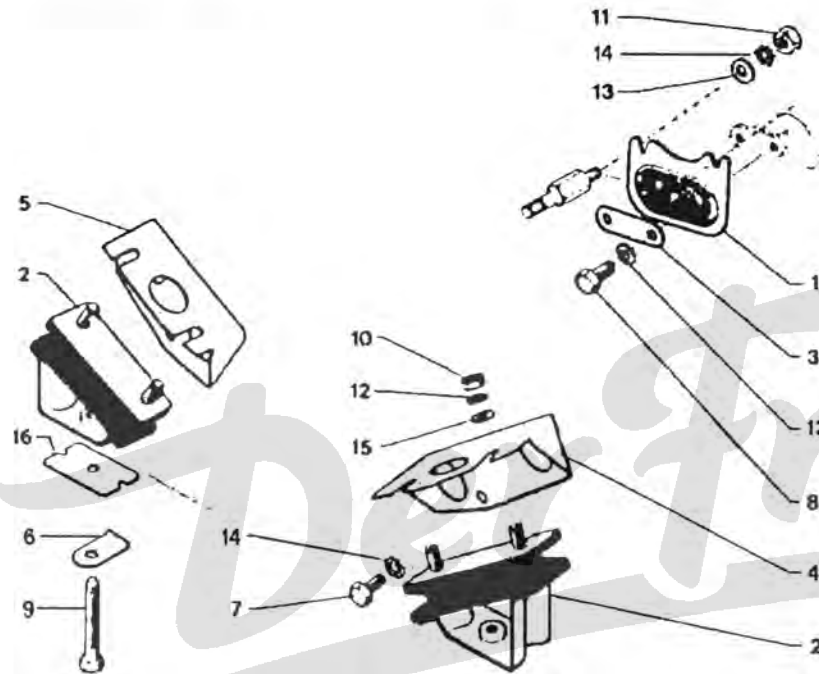

1114

6.133.10

Z1330100

14	79 03 056 017	06	DIAM 16 5X16,8	RONDELLE GROWER GROWERSCHEIBE SPRING WASHER ARANDELA RONDELLA GROWER
15	79 03 053 352	04	DIAM 25X7EP2	RONDELLE SCHEIBE SUSPENS WASHER ARANDELA RONDELLA

02/91  
17 06-1730-10  
AGE : 1  
04 ↑

**POMPE A ESSENCE ET CANALISATIONS**  
KRAFTSTOFFLEIGUNG  
FUEL PIPING  
CANALIZACION DE GAZOLINA  
CANALIZZAZIONE DELLA BENZINA

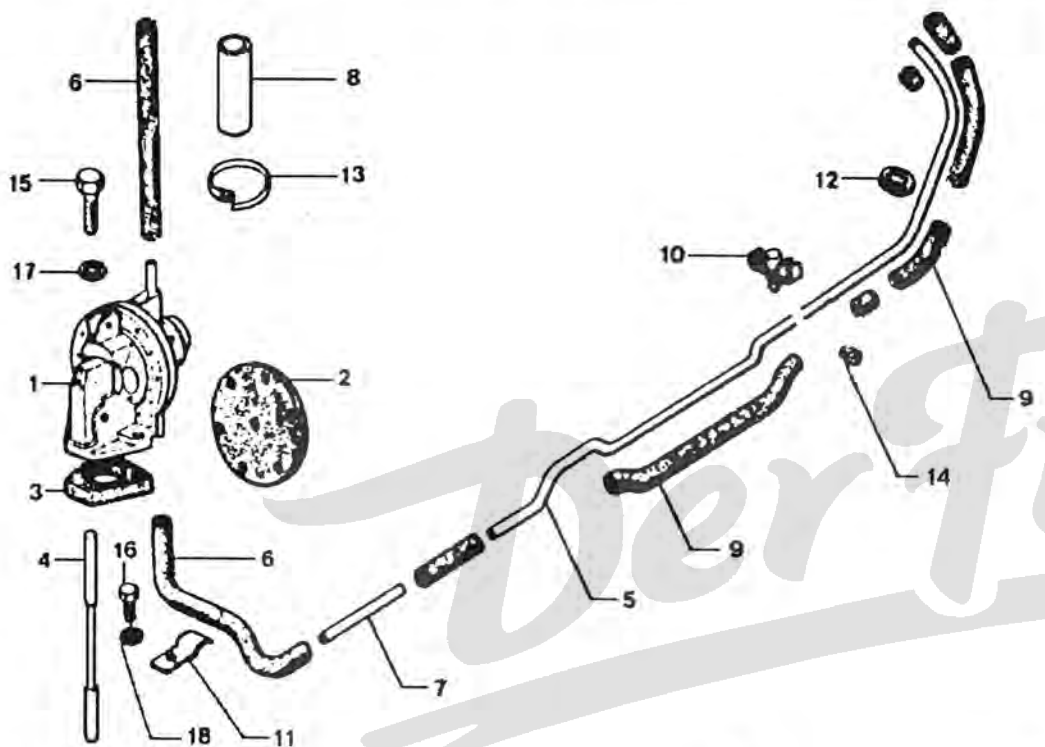

6/89 06.1730.10  
Z1730100

03	75 522 332	01		ENTRETOISE ABSTANDSSTUECK PUMP SPACER DISTANCIADOR DISTANZIALE
04	75 521 611	01	LON 110,7	TIGE DE CDE BETAETIG.STANGE CONTROL ROD VARILLA MANDO ASTA COMANDO
05	ZC 9910 511 U	99	4X6X6000	TUYAU CARBURANT LEITUNG FUEL FEED PIPE TUBO TUBO ALIMENTAZI
	79 05 026 709	01	DIAM 4,5X6 LON 4500	RACCORD VERBINDUNG RUBBER HOSE TUBO GOMA RACCORDO
06	26 231 249 RP 95655309	02	DIAM 5X12X950	-
07	5 400 918	01		TUBE DE LIAISON ZWISCHENROHR CONNECTING TUBE TUBO DE UNION TUBO. COLLEGAM.
08	79 05 026 967	02	DIAM9X15-80 1360 DAD	GAINE DE TUYAU ROHRHULLE PIPE SHEATH PROTECTOR TUBO GUAINA TUBO
09	26 234 279	01	DIAM 7 X 310	-
10	AM 174 221 A	07	1 DIAM 3,5-1 DIAM 6	AGRAFE KLAMMER CLIP GRAPA AGRAFE
11	95 624 196	01		PATTE HALTELASCHE SUPPORT LUG SOPORTE STAFFA

75 515 547	01		POMPE ESSENCE BENZINPUMPE PETROL PUMP BOMBA GASOLINA POMPA BENZINA
A 173 8	01		MEMBRANE DE PPE MEMBRANE DIAPHRAGM MEMBRANA BOMBA MEMBRANA

.../...

15/02/91  
 1117 06-1730-10  
 PAGE : 2  
 C05 ↑

**POMPE A ESSENCE ET CANALISATIONS**  
 KRAFTSTOFFLEIGUNG  
 FUEL PIPING  
 CANALIZACION DE GAZOLINA  
 CANALIZZAZIONE DELLA BENZINA

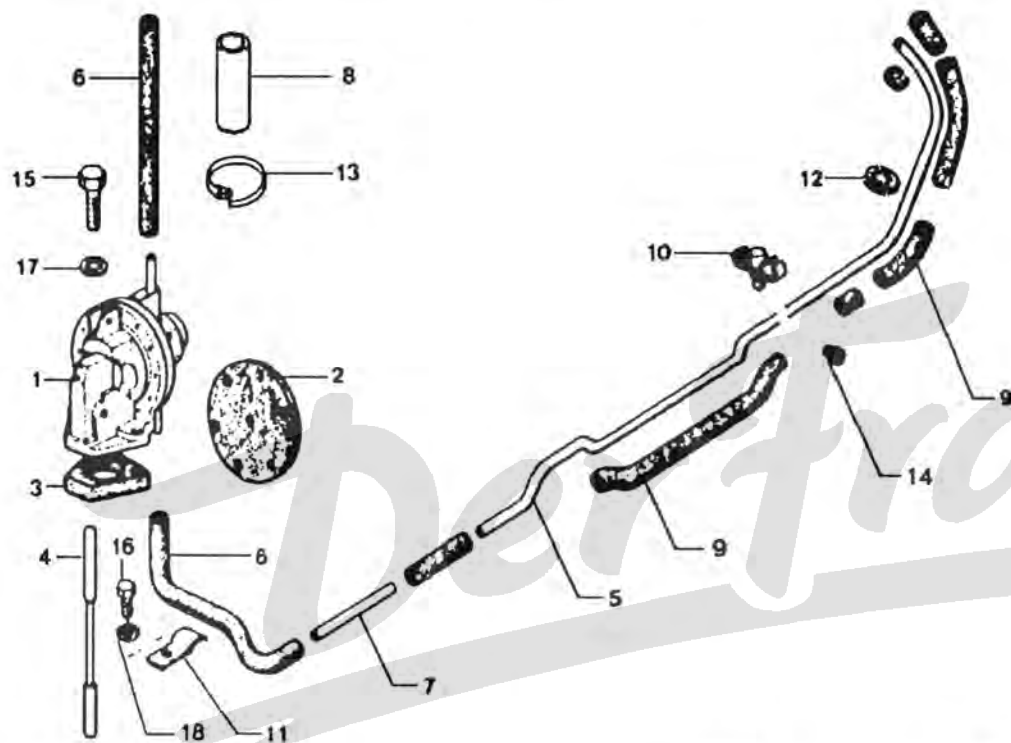

1117

6/89

06.1730.10

Z1730100

14	AY 644 101	06	DIAM 7 "PLASTIQUE"	BOUCHON STOPFEN PLUG TAPON TAPPO
15	23 746 509	02	7X1,00-38	VIS TH SCHRAUBE CAPSCREW TORNILLO TH VITE
16	79 03 001 806 RP 7903201012	01	5X16	-
17	79 03 058 011	02	DIAM 7,2X14,2-1,4	RONDELLE CONIQU KONUSSCHEIBE SPRING WASHER ARANDELA RONDELLA CONICA
18	26 192 349 RP 7903053372	01	DIAM 5,25X14X1	RONDELLE PLATE FLACHSCHEIBE PLAIN WASHER ARANDELA PLANA RONDELLA PIATTA
12	21 073 009	01	DIAM 8	OEILLET GUMMIOESE RUBBER GROMMET PASACABLE OCCHIELLO
13	79 03 083 153	99	LON 240	COLLIER SCHELLE BOOT CLAMP ABRAZADERA COLLARE

**RÉSERVOIR CARBURANT**  
KRAFTSTOFFTANK  
FUEL TANK  
DEPOSITO DE CARBURANTE  
SERBATOIO DELLA CARBURANTE

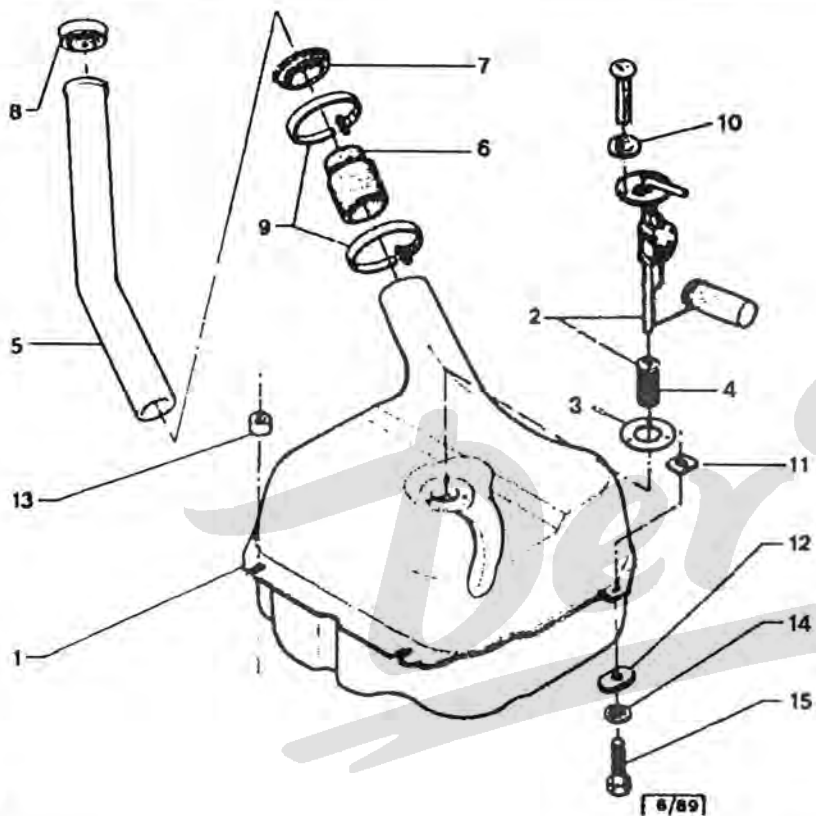

1117

06 1750 10  
Z1750100

03	5 402 981	01	36X55X1,5 CAOUTCHOUC	JOINT DICHTUNG FUEL TANK SEAL JUNTA GUARNIZIONE
04	5 478 012	01	NYLON	ELEMENT FILTRE ELEMENT FILTER ELEMENT ELEMENTO ELEMENTO
05	A 175 4 A	01	DIAM 45	TUBULURE STUTZEN FILLER PIPE TUBO LLENADO TUBO RIEMPIMENT
06	95 541 376	01	CAOUTCHOUC	RACCORD VERBINDUNG FILLER JOINT RACOR TUBO RACCORDO
07	96 995 620 RP HG17515	01	RMP ZC9807107U 2792 ▶	JOINT TUBULURE LEITUNGSDICHTUN FUEL PIP GASKET JUNTA TUBERIA GUARNIZIONE BOC
08	HG 175 15	01	-CHARLESTON 2793 ▶	-
08	5 506 214	01		BOUCHON VERSCHLUSS FILLER PLUG TAPON LLENADO TAPPO
	ZC 9866 056 U	01	" PJ "	BOUCHON ANTIVOL TANKDECKEL LOCKING CAP TAPON ANTIRROBO TAPPO ANTIFURTO
09	79 03 083 250	02	LON 580 LAR 5 RMP 22985029	COLLIER METAL METALLSCHELLE METALLIC CLAMP ABRAZADERA COLLARE METALL
10	5 412 295	03	4,5X8X0,5	RONDELLE ETC DICHTSCHEIBE SEAL WASHER ARANDELA RONDELLA

.../...

01	95 492 906	01	25L PLASTIQUE	RÉSERVOIR BEHAELTER FUEL TANK DEPOSITO SERBATOIO
02	95 493 438	01	JAEGER	RHEOSTAT MESSRHEOSTAT RHEOSTAT REOSTATO REOSTATO

15/02/91  
 1117 06-1750-10  
 PAGE : 2  
 C07 ↑

**RESERVOIR CARBURANT**  
**KRAFTSTOFFTANK**  
**FUEL TANK**  
**DEPOSITO DE CARBURANTE**  
**SERBATOIO DELLA CARBURANTE**

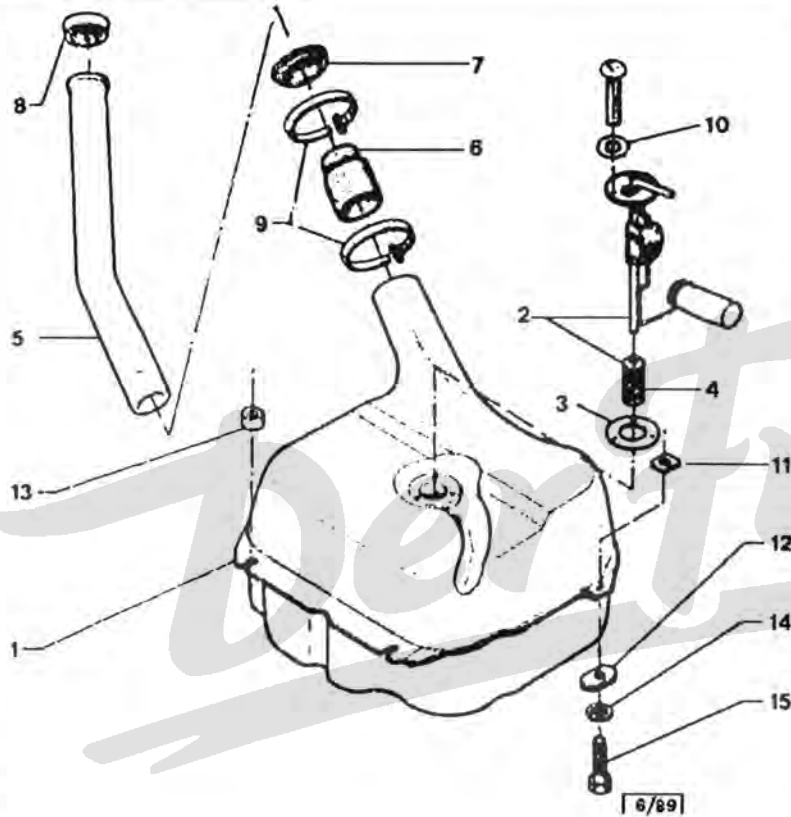

1117

06.1750.10  
 Z1750100

13	95 541 373	02	NYLON	RONDELLE SCHEIBE WASHER ARANDELA RONDELLA
14	79 03 058 029	04	DIAM 7,2 X14,2X1,4	RONDELLE CONIQU KONUSSCHEIBE SPRING WASHER ARANDELA RONDELLA CONICA
15	95 540 150	04	TH 7 X 35	VIS TH SCHRAUBE CAPSCREW TORNILLO TH VITE

11	22 996 029 RP 7903083271	02	LON 605	COLLIER SCHELLE ADJUST COLLAR ABRAZADERA COLLARE
	95 541 375	02	NYLON	CALE RESERVOIR UNTERLAGE BEH. FUEL TANK SHIM CALA DEPOSITO SPESSORE SERBAT
12	95 541 377	04		

15/02/91  
 1117 06-1750-11  
 PAGE : 1  
 C08 ↑

**RESERVOIR CARBURANT**  
 KRAFTSTOFFTANK  
 FUEL TANK  
 DEPOSITO DE CARBURANTE  
 SERBATOIO DELLA CARBURANTE

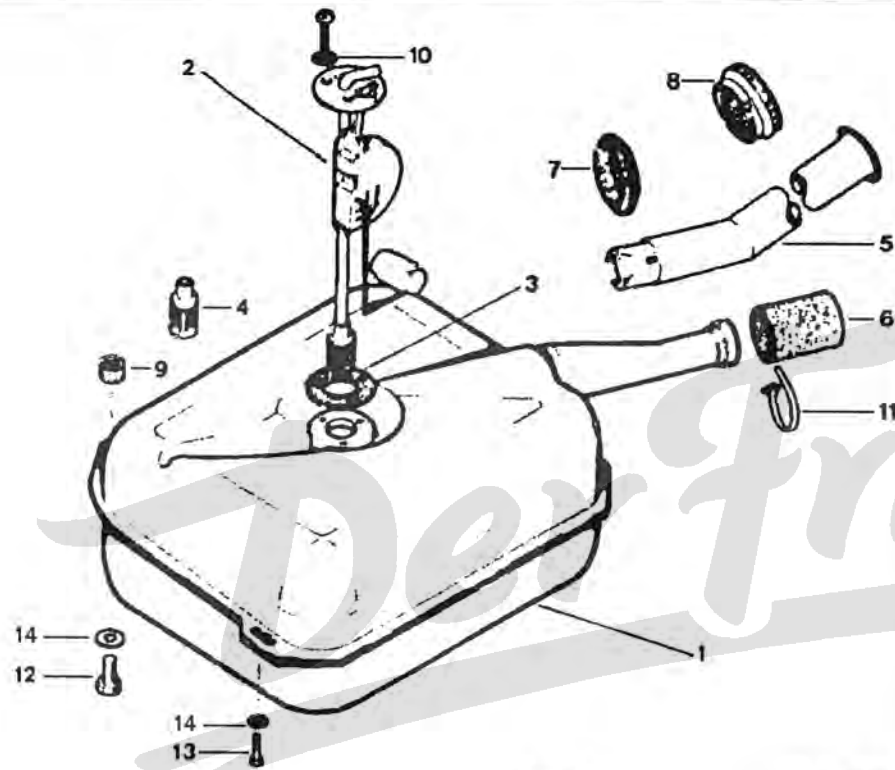

1117 [6/89] 06 1750.11  
 Z1750110

(D)

01	95 492 906	01	25L PLASTIQUE RMP 5467788	RESERVOIR BEHAELTER FUEL TANK DEPOSITO SERBATOIO
02	5 490 692	01	JAEGER ▶ 05/80	RHEOSTAT MESSRHEOSTAT RHEOSTAT REOSTATO REOSTATO
	95 493 438	01	JAEGER 05/80 ▶	-

03	5 402 981	01	36X55X1,5 CAOUTCHOUC	JOINT DICHTUNG FUEL TANK SEAL JUNTA GUARNIZIONE
04	5 478 012	01		ELEMENT FILTRE ELEMENT FILTER ELEMENT ELEMENTO ELEMENTO
05	A 175 4 A	01	DIAM 45	TUBULURE STUTZEN FILLER PIPE TUBO LLENADO TUBO RIEMPIMENT
06	95 589 471	01	44X52X70	RACCORD VERBINDUNG RUBBER HOSE TUBO GOMA RACCORDO
07	98 995 620 RP HG17515	01	RMP ZC9807107U	JOINT TUBULURE LEITUNGSDICHTUN FUEL PIP GASKET JUNTA TUBERIA GUARNIZIONE BOC
08	5 506 214	01		BOUCHON VERSCHLUSS FILLER PLUG TAPON LLENADO TAPPO
	ZC 9866 056 U	01	" PJ "	BOUCHON ANTIVOL TANKL'ECKEL LOCKING CAP TAPON ANTIRROBO TAPPO ANTIFURTO
09	95 541 373	02		RONDELLE SCHEIBE WASHER ARANDELA RONDELLA
10	5 412 295	03	4,5X8X0,5	RONDELLE ETC DICHTSCHEIBE SEAL WASHER ARANDELA RONDELLA

.../...



15/02/91  
 1117 06-1750-11  
 PAGE : 2  
 C09 ↑

**RESERVOIR CARBURANT**  
**KRAFTSTOFFTANK**  
**FUEL TANK**  
**DEPOSITO DE CARBURANTE**  
**SERBATOIO DELLA CARBURANTE**

14

79 03 058 029

04

DIAM 7,2 X14,2X1,4  
 RMP 23450319

**RONDELLE CONIQU**  
**KONUSSCHEIBE**  
**SPRING WASHER**  
**ARANDELA**  
**RONDELLA CONICA**

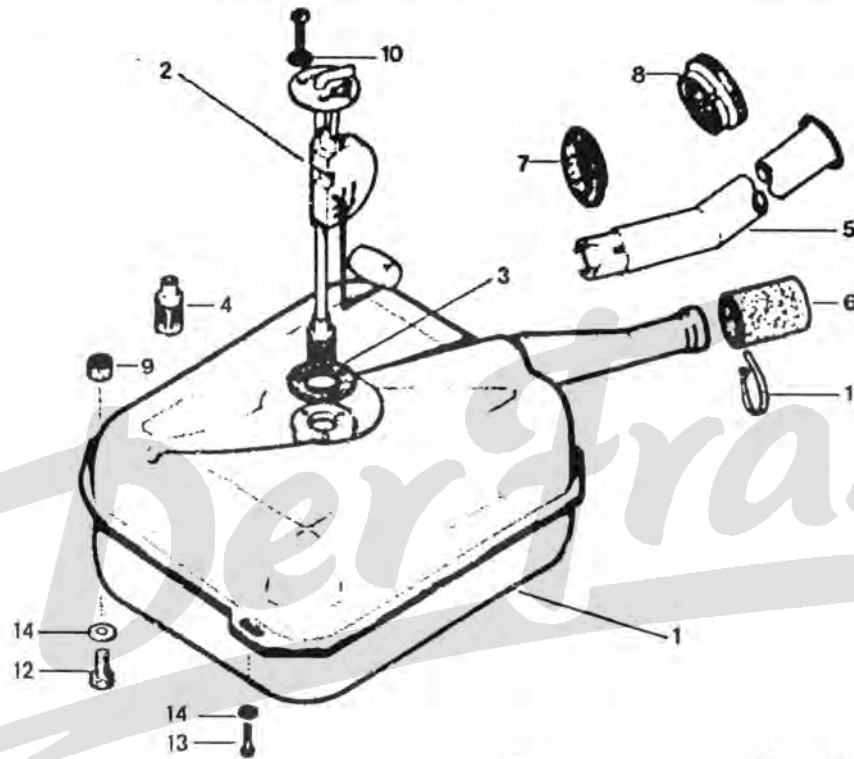

1117

2/89

06 1750.11

Z1750110

(D)

11	79 03 083 271	02	LON 690 LAR 8 RMP22996029	COLLIER METAL METALLSCHELLE METALLIC CLAMP ABRAZADERA COLLARE METALL
12	23 707 019	02	TH 7X100-28	VIS TH SCHRAUBE CAPSCREW TORNILLO TH VITE
13	79 03 101 769	02	DIAM 7X45 RMP 23450319	

5/02/91  
 117 06-1830-10  
 AGE : 1  
 10 ↑

**ECHAPPEMENT AVANT**  
 AUSPUFFANLAGE VORN  
 EXHAUST FRONT  
 ESCAPE DELANTERO  
 SCARICO ANTERIORE

$\frac{1}{3+6+7}$

$\frac{2}{5+6}$

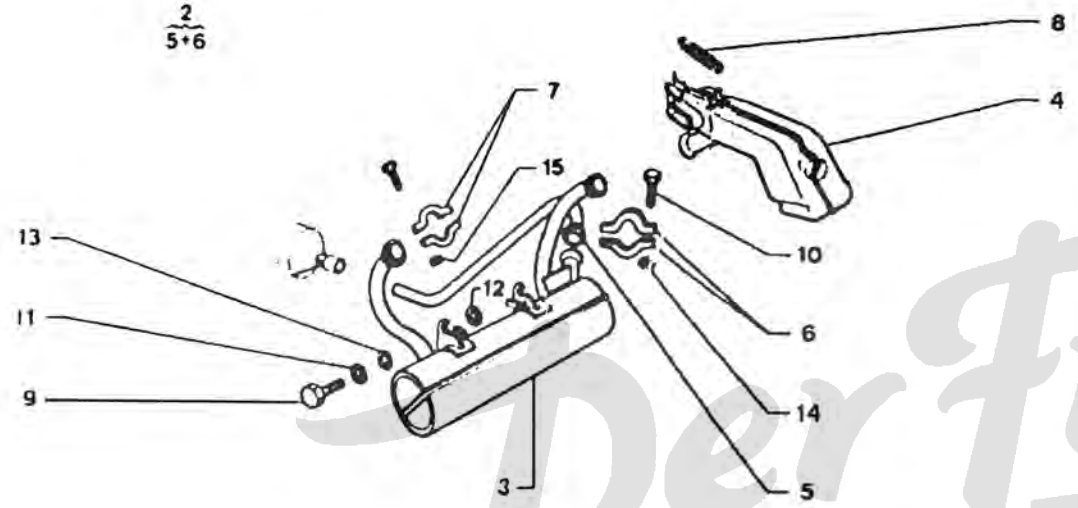

[6/89]

6.1830 10

Z1830100

LES PIECES NON REPEREES SONT N F P

75 527 203	01	ENS "PAM" LUCHAIRE	POT DE DETENTE AUSPUFFTOPF EXHAUST DAMPER SILENCIADOR COL MARMITTA ESPANS
5 429 093	01	ENS "PAM"	TUYAU INTM ECH AUSPUFFROHR EXHAUST PIPE TUBO ESCAPE TUBO SCARICO

03	5 490 718	01	LUCHAIRE RMP5465334	POT DE DETENTE AUSPUFFTOPF EXHAUST DAMPER SILENCIADOR COL MARMITTA ESPANS
04	95 548 497	01	D- RMP 75512835	1666 ▶ ECHANGEUR D'AIR AUSTAUSCHER DISTRIB CHAMBER INTERCAMBIADOR SCAMBIATORE
	95 548 494	01	G- RMP 75512833	1666 ▶ -
05	AY 182 4	01		TUYAU INTM ECH AUSPUFFROHR EXHAUST PIPE TUBO ESCAPE TUBO SCARICO
06	AM 182 6 B	02		DEMI-COLLIER SCHELLENHAELFTE HALF CLAMP SEMI ABRAZADERA SEMIFASCETTA
07	75 420 467	08		COLLIER SCHELLE FIXING CLAMP ABRAZADERA COLLARE
08	AY 9182 230 A	02		RESSORT BEFESTIG.-FEDER PIPE SPRING M'ELLE FIJACION MOLLA FISSAGGIO
09	79 03 101 771	06	DIAM7X100-20 RMP 23719319	VIS TH SCHRAUBE CAPSCREW TORNILLO TH VITE
10	79 03 101 757	10	DIAM 7X1,00 - 35 RMP23459519	4498 ▶ -
11	79 03 058 029	02	DIAM 7,2 X14.2X1,4	RONDELLE CONIQU KOHUSSCHEIBE SPRING WASHER ARANDELA RONDELLA CONICA

.../...

15/02/91  
 1117 06-1830-10  
 PAGE : 2  
 C11 ↑

**ECHAPPEMENT AVANT**  
 AUSPUFFANLAGE VORN  
 EXHAUST FRONT  
 ESCAPE DELANTERO  
 SCARICO ANTERIORE

53

5 490 413  
 RP 5490720

**XT**

01 CHESWICK  
 -CAD

POT DE DETENTE  
 AUS.PUFFTOPF  
 EXHAUST DAMPER  
 SILENCIADOR COL  
 MARMITTA ESPANS

5 490 720

01 LUCHAIRE  
 -CAD

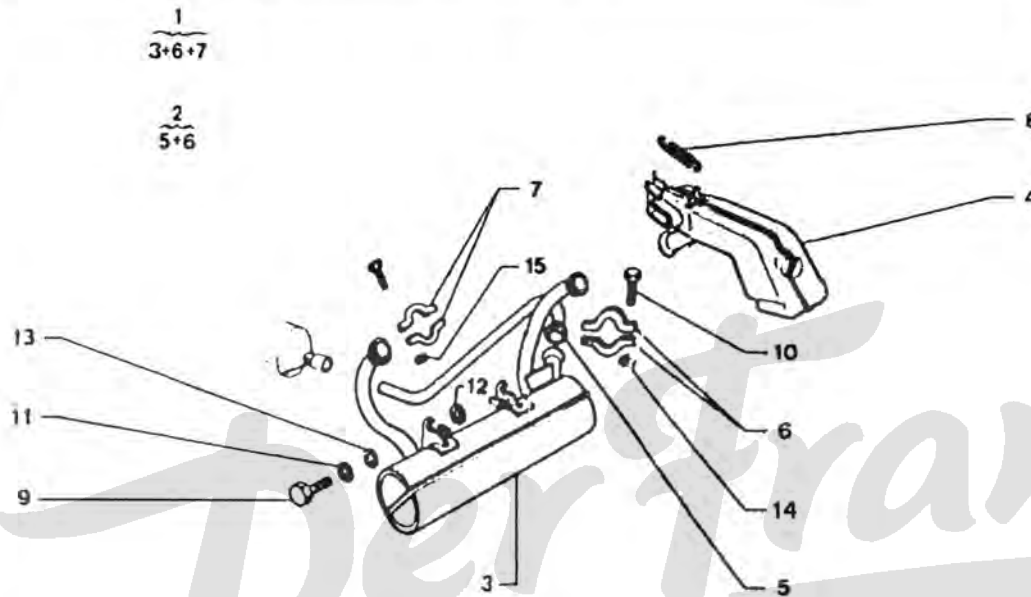

1117

6/89

6.1830 10

Z1830100

12	95 624 273	02 DIAM 7,4 X 20 X 2 RMP 7903053374	RONDELLE PLATE FLACHSCHEIBE PLAIN WASHER ARANDELA PLANA RONDELLA PIATTA
13	22 965 039	02 DIAM 8,5X24X2	-
14	79 03 032 249	10 HE 7X1,00 RMP 25210089	ECROU MUTTER NUT TUERCA DADO

15/02/91  
 1117 06-1848-20  
 PAGE : 1  
 C12 ↑

**ECHAPPEMENT ARRIERE**  
 AUSPUFFANLAGE,HINTEN  
 EXHAUST. REAR PART  
 ESCAPE TRAS. PARTE TRASERA  
 SCERICO POST. PARTE POSTERIORE

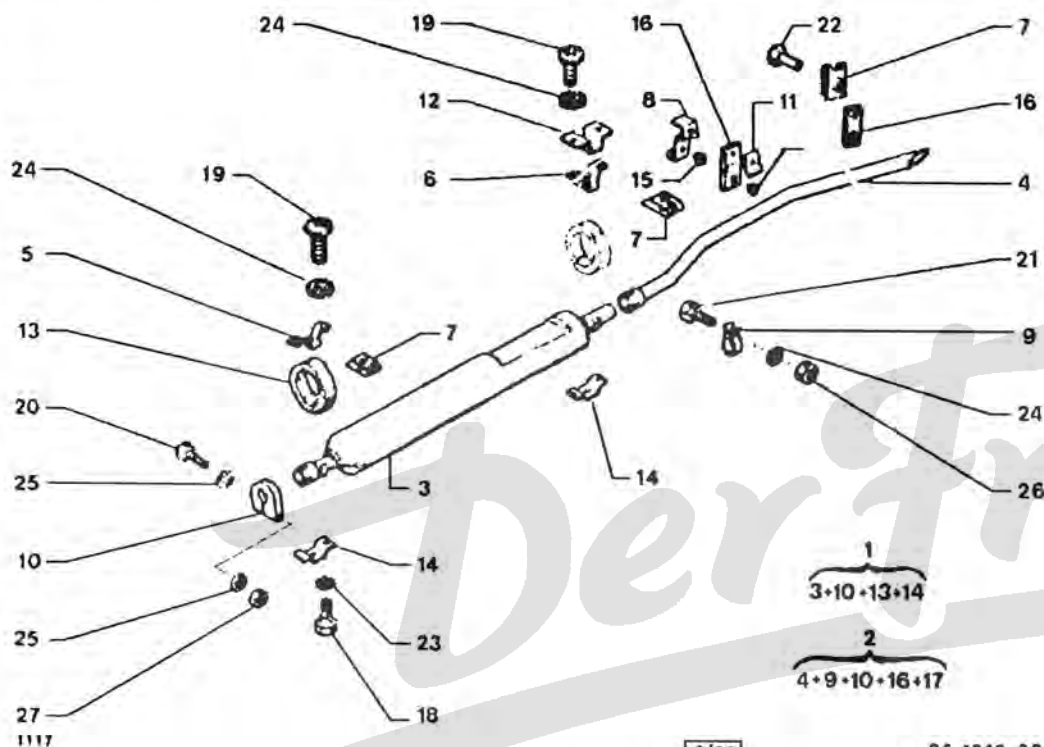

[6/89]

06 1848.20

Z1848200

01	75 525 430	01	ENS'PAM' LUCHAIRE	SILENCIEUX AR SCHALLDAEMPF.H. EXH RR MUFFLER SILENCIOSO AR SILENZIATORE PO
02	75 518 015	01	AR-ENS'PAM'	TUYAU AR ECH AUSPUFFROHR H. TAIL PIPE TUBO AR ECH TUBO POST.

03	95 495 446	01	LUCHAIRE 1939 ▶ RMP 75492264	SILENCIEUX AR SCHALLDAEMPF.H. EXH RR MUFFLER SILENCIOSO AR SILENZIATORE PO
04	75 510 647	01		TUYAU AR ECH AUSPUFFROHR H. TAIL PIPE TUBO AR ECH TUBO POST.
05	AM 183 81	01	AV	SUPPORT HALTER PIPE BRACKET SOPORTE SUPPORTO
06	AY 182 122	01	AR RMP AY18264	SUPPORT SUS. AR HALTER SUSPEN BRACKET SOPORTE SUPPORTO
07	26 158 299	05	CLIP 7X100	ECROU TOLE BLECHMUTTER SPEED NUT TUERCA CHAPA DADO LAMIERA
08	5 503 759	01		SUPPORT HALTER PIPE BRACKET SOPORTE SUPPORTO
09	AY 182 101	02		COLLIER SCHELLE FIXING CLAMP ABRAZADERA COLLARE
10	79 03 083 237	02	DIAM 36 2765 ▶ RMP 75510651	-
11	AM 182 84	02		PLAQUETTE PLAKETTE EXHST PIP PLATE PLAQUETA PIASTRINA
12	AY 182 123	02		PONTET STEG HITCH BRACKET PROTECTOR SUPPORTO

.../...

15/02/91  
1117 06-1848-20  
PAGE : 2  
C13 ↑

**ECHAPPEMENT ARRIERE**  
AUSPUFFANLAGE, HINTEN  
EXHAUST, REAR PART  
ESCAPE TRAS. PARTE TRASERA  
SCERICO POST. PARTE POSTERIORE

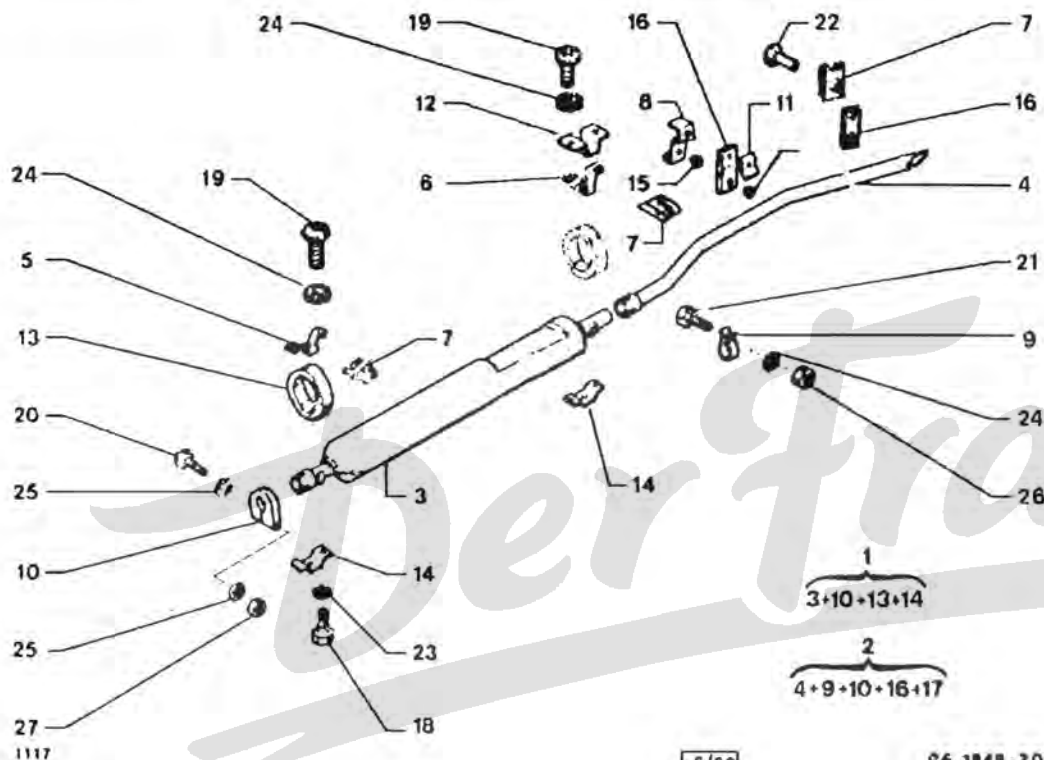

6/89

96 1848-20

Z1848200

13 AM 183 48

02 CC

BAGUE ELASTIQUE  
RING  
BUSHING  
CASQUILLO ELAS.  
BOCCOLA ELAST.

14 AM 183 88

02

BRIDE DE BAGUE  
FLANSCH  
FLEXRING CLAMP  
BRIDA DE CASQU.  
STAFFA

15	AM 182 285 A	01	CC	BUTEE CAOUTCHOU ANSCHLAG RUBBER BUFFER TOPE GOMA REGGISPINTA
16	5 410 471	01	CC-AV 85X30X8	PLAQUETTE PLAKETTE EXHST PIP PLATE PLAQUETA PIASTRINA
17	DX 182 80 A	01	CC-AR-126X30X6	-
17	5 410 472	04		ENTRETOISE - ABSTANDSSTUECK PIPE SPACER DISTANCIADOR Distanziale
18	79 03 201 130	02	DIAM 5 X 0,80 - 16 RMP 7903101282	VIS TH SCHRAUBE CAPSCREW TORNILLO TH VITE
19	79 03 001 708	04	DIAM 7X1,00-20	-
20	79 03 201 041 RP 96995862	02	DIAM8X1,25-65 RMP 7903001846	2764 ▶ -
21	95 623 773	06	TH7X1,00-25 RMP 23720319	VIS SCHRAUBE SCREW TORNILLO VITE
22	79 03 001 603	08	DIAM 7X1,00-40 RMP 23747019	VIS TH SCHRAUBE CAPSCREW TORNILLO TH VITE
23	79 03 056 005	02	DIAM 5,3X9,4	RONDELLE A DENT ZAHNSCHEIBE SPRING WASHER ARANDELA RONDELLA DENTAT
24	79 03 056 012	99	CR 7,3X12	RONDELLE GROWER GROWERSCHEIBE SPRING WASHER ARANDELA RONDELLA GROWER

.../...

5/02/91  
 117 06-1848-20  
 PAGE : 3  
 :14 ↑

**ECHAPPEMENT ARRIERE**  
 AUSPUFFANLAGE,HINTEN  
 EXHAUST. REAR PART  
 ESCAPE TRAS. PARTE TRASERA  
 SCERICO POST. PARTE POSTERIORE

27	79 03 232 031	04	HE 8X1,25 RMP 7903032217	2764 ▶	ECROU HEXAGONAL SECHSKANTMUTTER HEXAGONAL NUT TUERCA DADO ESAGONALE
----	---------------	----	-----------------------------	--------	---

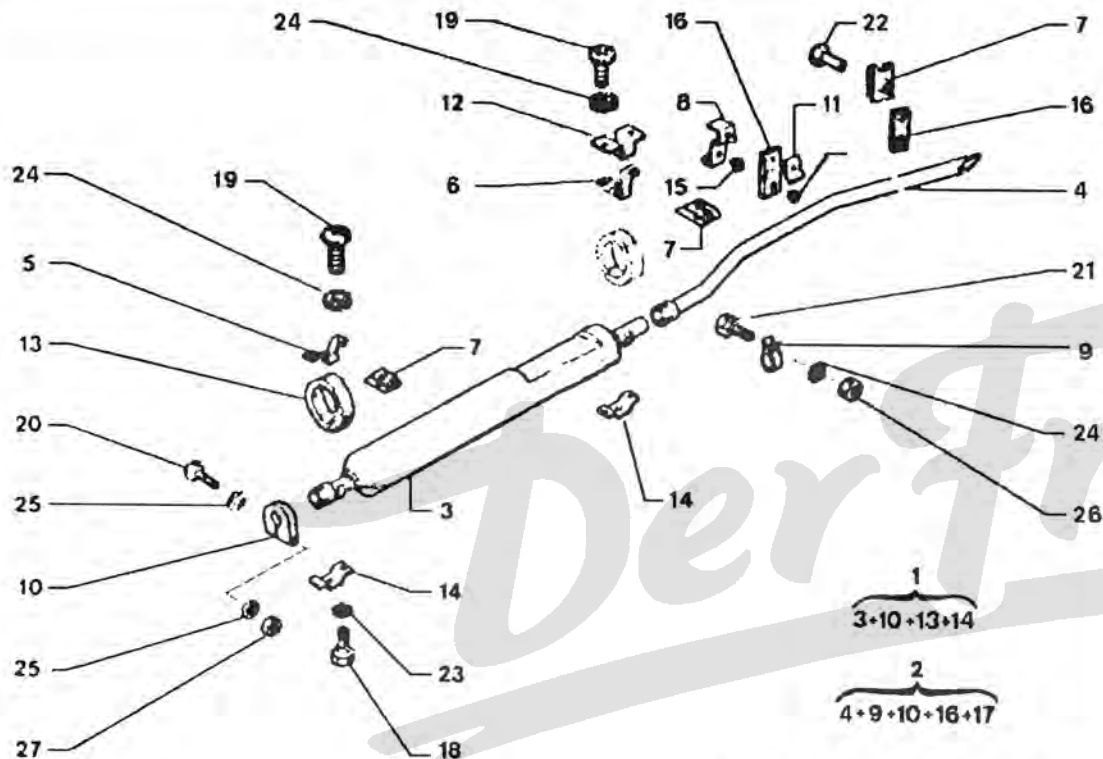

[6/89]

06 1848,20

Z1848200

54	75 510 648	01	-CAD	XT	TUYAU AR ECH AUSPUFFROHR H. TAIL PIPE TUBO AR ECH TUBO POST.
58	AYA 182 68	01	AR -CAD		SUPPORT HALTER PIPE BRACKET SOPORTE SUPPORTO
66	AM 182 75	01	AR -CAD		PLAQUETTE PLAKETTE EXHST PIP PLATE PLAQUETA PIASTRINA

22 541 019

99 DIAM 8,5X15 EP2

2764 ▶

RONDELLE PLATE  
 FLACHSCHEIBE  
 PLAIN WASHER  
 ARANDELA PLANA  
 RONDELLA PIATTA

79 03 032 036

99 HE 7X1,00-5,5

ECROU  
 MUTTER  
 NUT  
 TUERCA  
 DADO

15/02/91  
 1117 06-2421-10  
 PAGE : 1  
 C15 →

**REFROIDISSEMENT MOTEUR-TOLE-VENTILATEUR**  
 KUEHLUNG - GEBLAESERAD - LUFTFUEHRUNG  
 COOLING - FAN - AIR INTAKE  
 REFRIGERACION-COLECTOR DE AIRE-VENTIL.  
 RAFFREDDAMENTO-CONVOGLIATORE DELL'ARIA

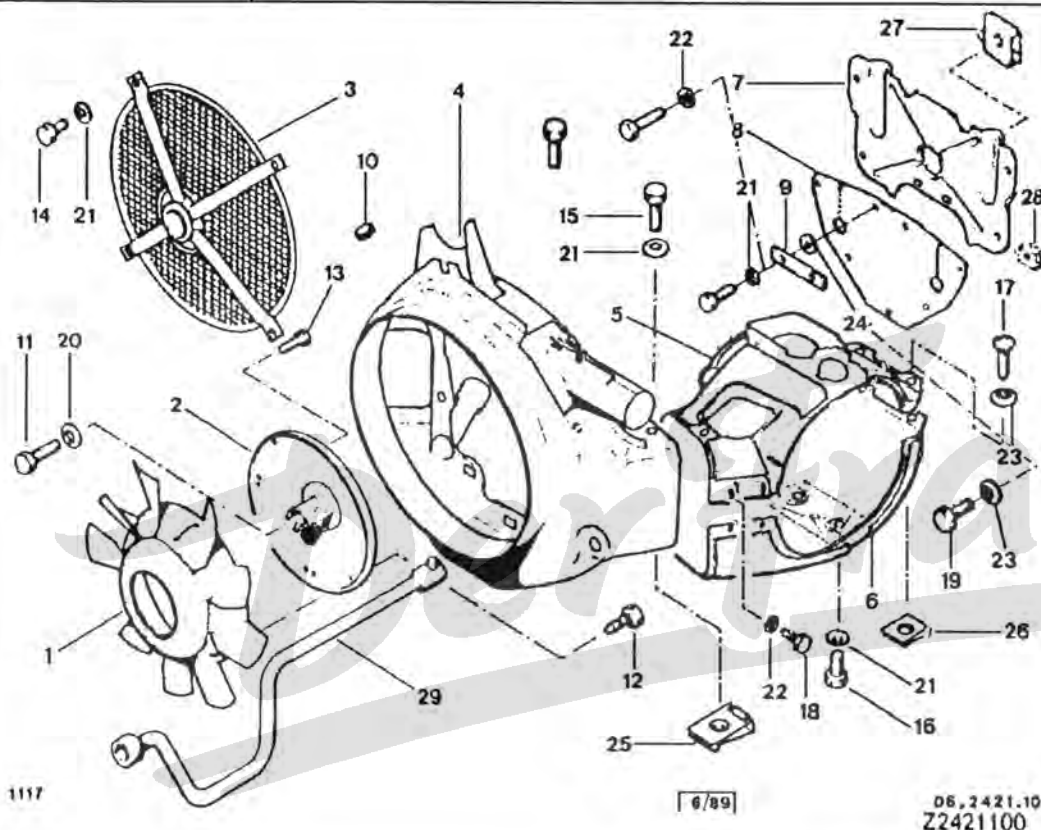

• 1POS: TOLE - 2POS: THERMO-FORME (KELLER)

01	75 515 916	01 9PALES RMP 75510956	VENTILATEUR VENTILATOR ENGINE FAN VENTILADOR VENTOLA MOTORE
02	5 508 141	01 2 POS RMP 5424106 - 1POS	POULIE RIEMENSCHIBE FAN PULLEY POLEA PULEGGIA

03	AK 251 87 A	01 4 DIAM 7	GRILLE GITTER PROTECT GRILLE REJILLA GRIGLIA
04	75 523 580	01	▶ 1665 COLLECTEUR AIR LUFTFUEHRUNG AIR INTAKE COLECTOR CONVOGLIAT. ARIA
	95 578 338	01 RMP 95566370	2061 ▶ -
05	5 478 994	01 G- 1 POS SUP	2061 ▶ INSONORISANT GERAEUSCHDAEMM. SOUND PROOFING INSONORIZANTE INSONORIZZANTE
	95 578 335	01 G- 2 POS SUP	2739 ▶ -
	5 478 995	01 D- 1 POS SUP	-
	95 578 334	01 D- 2 POS SUP	2739 ▶ -
06	75 478 985	01 G- 1 POS INF	-
	95 578 337	01 G- 2 POS INF	2739 ▶ -
	75 478 986	01 D- 1 POS INF	-
	95 578 336	01 D- 2 POS INF	2739 ▶ -
07	95 607 711	01 ENS RMP AM242267A	TOLE DE CONDUIT LUFTFUEHR.BLECH DUCT PLATE CHAPA CONDUCTO LAMIERA CONDOT.
08	95 544 253	01 CAOUTCHOUC RMP AM242268A	▶ 2213 -
	95 573 482	01	2213 ▶ ETANCHEITE ABDICHTUNG SEALING ESTANQUEIDAD TENUTA
09	95 573 483	02	2213 ▶ BARRETTE RETENU HALTELEISTE RETAINER BAR SOP.RETENCION PONTICELLO RIT.

.../...

02/91  
17 06-2421-10  
AGE : 2  
15 ↓

**REFROIDISSEMENT MOTEUR-TOLE-VENTILATEUR**  
KUEHLUNG - GEBLAESERAD - LUFTFUEHRUNG  
COOLING - FAN - AIR INTAKE  
REFRIGERACION-COLECTOR DE AIRE-VENTIL.  
RAFFREDDAMENTO-CONVOGLIATORE DELL'ARIA

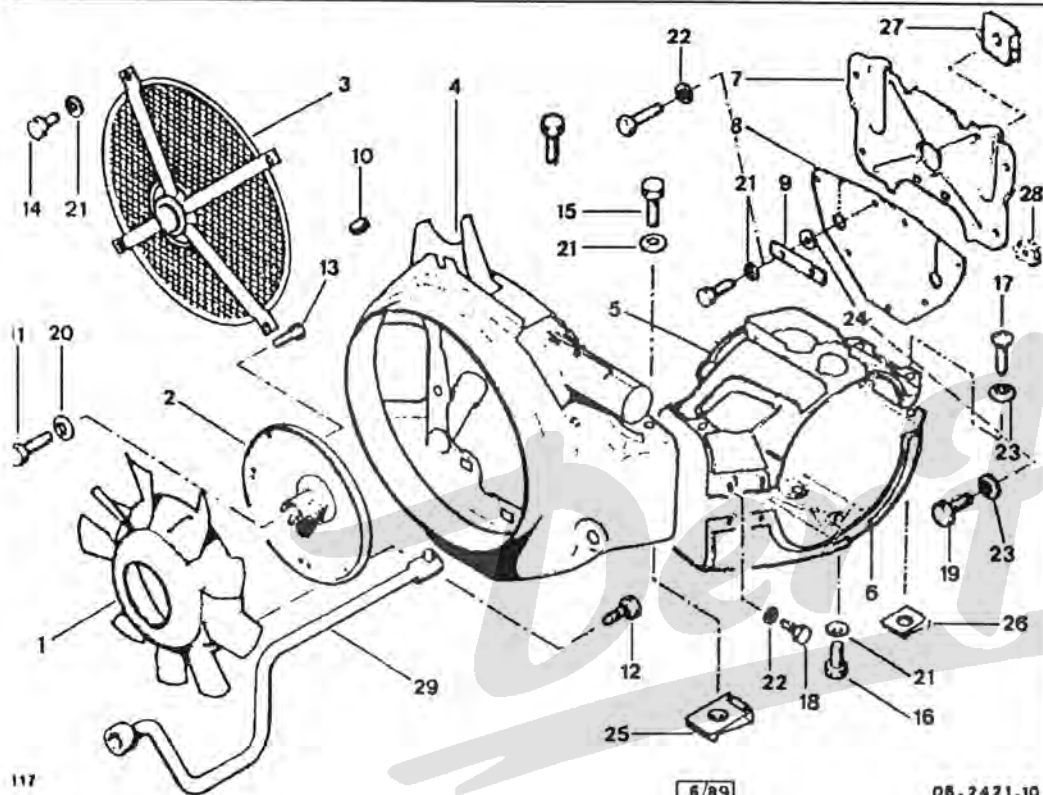

26 130 489

95 499 045

75 420 175

01

01

04

TH 10X36  
RMP 7903001554

7X22

06/80 ▶

**OBTURATEUR**  
STOPFEN  
PLUG  
OBTURADOR  
OTTURATORE  
A  
**VIS TH**  
SCHRAUBE  
CAPSCREW  
TORNILLO TH  
VITE

13

14

15

16

17

18

19

20

21

22

26 139 009

23 718 019  
RP 7903101752

79 03 201 130

79 03 101 770

79 03 016 283

79 03 016 086

95 594 987

79 03 001 673  
RP 7903201132  
DEO 22770069 (01)

79 03 201 129

79 03 055 019

79 03 058 011

79 03 058 027

03 TH 5X20

04 DIAM 7X1,00 - 12

20 DIAM 5 X 0,80 - 16  
RMP 7903101282-7903101283

03 DIAM 7X1,00-18  
RMP 23451319

14 DIAM 4,8X13

14 TCB4,85X25 2061 ▶ 2701  
RMP 7903016167 DEO 95623757

14 DIAM 4,8 X 20

06 TH 5X0,80-25

01 DIAM 5X0,80-12

01 DIAM 10  
RMP 22633009

04 DIAM 7,2X14,2-1,4  
RMP 22904019

08 DIAM 5X12X1,2

2792 ▶

▶ 2060

2061 ▶ 2701

2702 ▶

2739 ▶

2781 ▶

2792 ▶

**VIS TH**  
SCHRAUBE  
CAPSCREW  
TORNILLO TH  
VITE

**VIS TOLE TCB**  
BLECHSCHRAUBE  
TAPPING SCREW  
TORNILLO CHAPA  
VITE

**VIS TOLE TH**  
BLECHSCHRAUBE  
TAPPING SCREW  
TORNILLO TH  
VITE LAMIERA

**VIS TH**  
SCHRAUBE  
CAPSCREW  
TORNILLO TH  
VITE

**RONDELLE GROWER**  
GROWERSCHEIBE  
SPRING WASHER  
ARANDELA  
RONDELLA GROWER

**RONDELLE CONIQU**  
KONUSSCHEIBE  
SPRING WASHER  
ARANDELA  
RONDELLA CONICA

**RONDELLE A DENT**  
ZAHNSCHEIBE  
SPRING WASHER  
ARANDELA  
RONDELLA DENTAT

.../...



15/02/91  
1117 06-2421-10  
PAGE : 3  
D14 ↓

**REFROIDISSEMENT MOTEUR-TOLE-VENTILATEUR**  
KUEHLUNG - GEBLAESERAD - LUFTFUEHRUNG  
COOLING - FAN - AIR INTAKE  
REFRIGERACION-COLECTOR DE AIRE-VENTIL.  
RAFFREDDAMENTO-CONVOGLIATORE DELL'ARIA

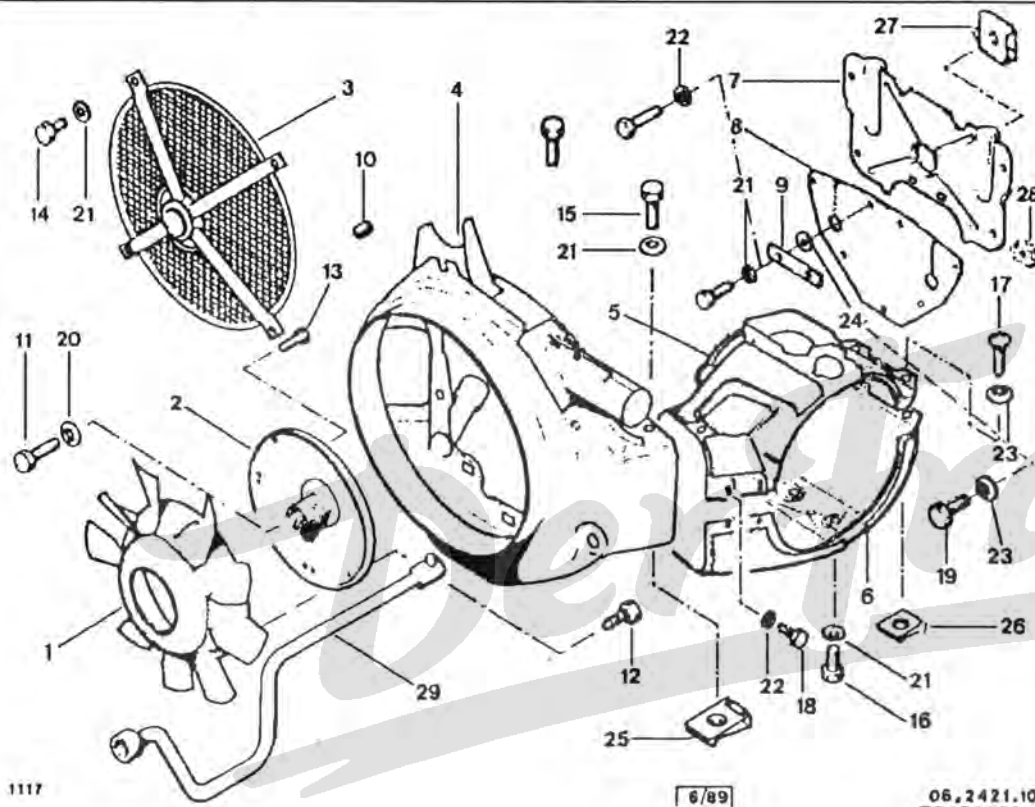

1117

6/89

06.2421.10  
Z2421100

25	79 03 046 067	14	2POS DIAM4,8 RMP 7903046068	2739 ▶	ECROU TOLE BLECHMUTTER SPEED NUT TUERCA CHAPA DADO LAMIERA
26	26 157 109 RP 7903046037	14	1POS-CLIP DIAM4,85	-	-
27	ZC 9615 859 U	04	CLIP -DIAM 5X0,80	2213 ▶	ECROU MUTTER NUT TUERCA DADO
28	26 158 259	08	DIAM 5X0,80 RMP ZC9615325W	2213 ▶	ECROU EN CAGE KAFIGMUTTER CAGED NUT TUERCA EN CAJA DADO IN GABBIA
29	A 251 1 A	01	LON52		VI: EBREQUIN KURBEL WHEEL BRACE BERBIQUI ALBERO RUOTA
<b>XT</b>					
52	95 577 224	01	-(CH)	2123 ▶	POULIE RIEMENSCHIBE FAN PULLEY POLEA PULEGGIA
54	95 540 634	01	-(D) -(A)	11/79 ▶	TOLE BLECH PANEL CHAPA LAMIERA ANT.
56	95 579 170	01	G. INF -(D) -(A) -(I) -(CH) -(DK)	2031 ▶	CONDUIT D'AIR LUFTFUEHRUNG HOOD AIR CHANNL CONDUCTO AIRE CONDOTTO ARIA
	95 579 171	01	D. INF -(D) -(A) -(I) -(CH) -(DK)	2031 ▶	-
80	AY 242 66	01	INF -(D) -(A)		TOLE PROTECTION ABSCHIRMBLECH GUARD SHEET MET PANTALLA PROTEC LAMIERA

23	95 623 757	03	DIAM 5X16 RMP 7903058038		RONDELLE A DENT ZAHNSCHIBE SPRING WASHER ARANDELA RONDELLA DENTAT
24	26 192 059 RP 22770069	02	DIAM 5X14	2213 ▶	RONDELLE PLATE FLACHSCHIBE PLAIN WASHER ARANDELA PLANA RONDELLA PIATTA

5/02/91  
 117 06-2421-10  
 PAGE : 4  
 013 ↓

**REFROIDISSEMENT MOTEUR-TOLE-VENTILATEUR**  
 KUEHLUNG - GEBLAESERAD - LUFTFUEHRUNG  
 COOLING - FAN - AIR INTAKE  
 REFRIGERACION-COLECTOR DE AIRE-VENTIL.  
 RAFFREDDAMENTO-CONVOGLIATORE DELL'ARIA

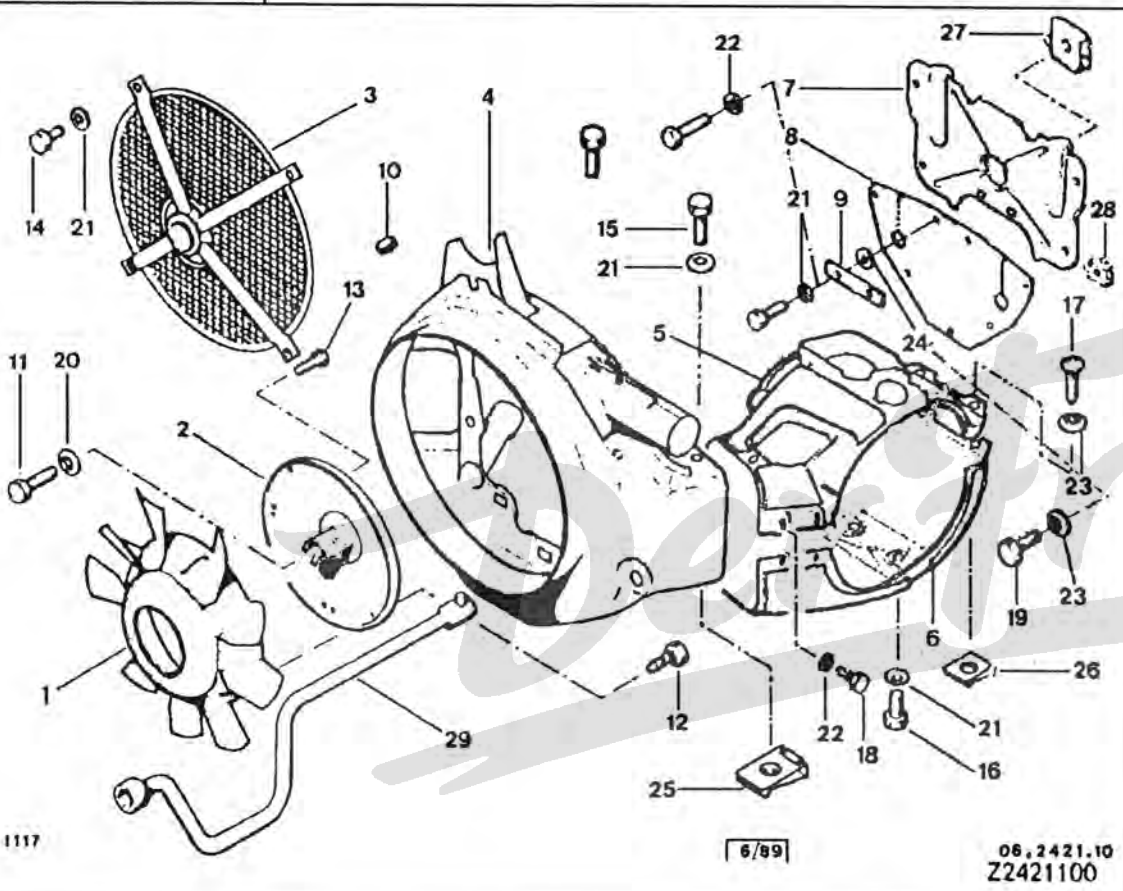

82	95 624 273	02	DIAM 7,4 X 20 X 2 -(D) -(A) RMP 7903053374	11/79 ▶	RONDELLE PLATE FLACHSCHEIBE PLAIN WASHER ARANDELA PLANA RONDELLA PIATTA
83	79 03 053 033 RP 7903053492	02	DIAM 6X1 8X2 -(D) -(A)		
84	79 03 044 001	02	CAGE 6X1,00 -(D) -(A)	11/79 ▶	ECROU EN CAGE KAEFIGMUTTER CAGED NUT TUERCA EN CAJA DADO IN GABBIA

AY 242 67	01	SUP -(D) -(A)	TOLE PROTECTION ABSCHIRMBLECH GUARD SHEET MET PANTALLA PROTEC LAMIERA
79 03 201 138	02	DIAM 6X1,00-12 -(D) -(A) RMP 7903101292	11/79 ▶ VIS TH SCHRAUBE CAPSCREW TORNILLO TH VITE

15/02/91  
1117 06-6171-10  
PAGE : 1  
D12 ↓

**PARE-CHOC AVANT**  
VORDERE STOSSSTANGE  
FRONT BUMPER  
PARECHOQUES DELANTEROS  
PARAURTI ANTERIORI

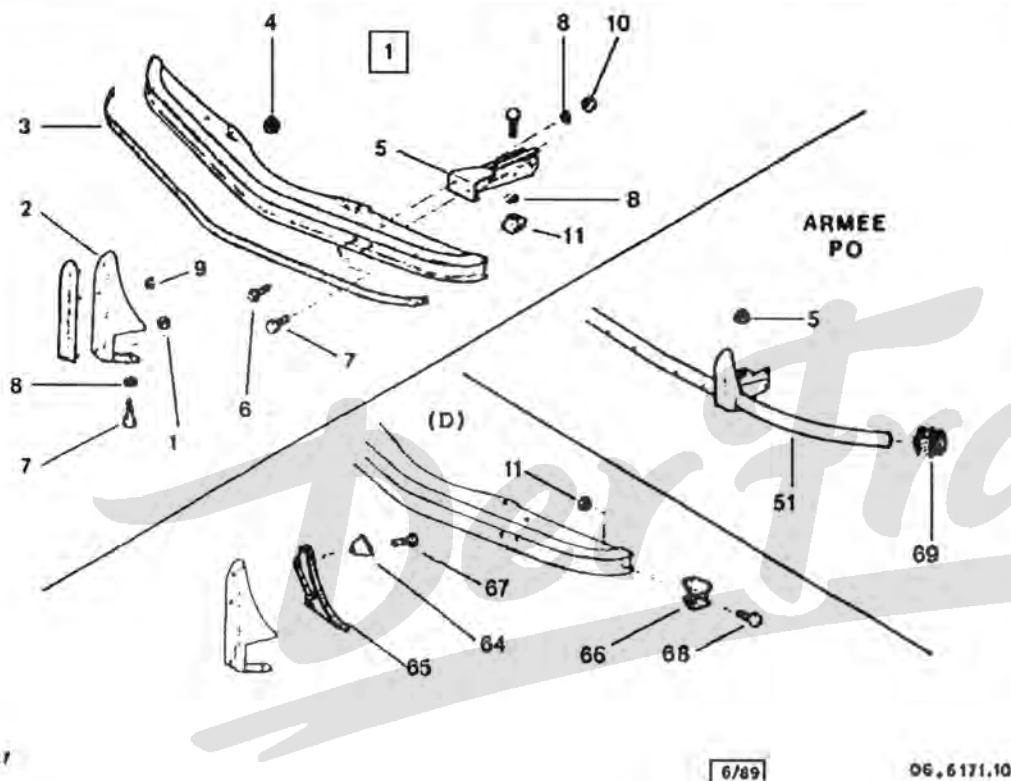

1117

[6/89]

06.6171.10

Z6171100

- LES PIECES NON REPEREES SONT N F P

01	95 624 963 VA	01 RMP	LAME PARE-CH.AV STANGE FRONT BUMPER LEAF HOJA PARAURTI
02	95 624 964	02 RMP	BUTOIR PUFFER BUMPER GUARD TOPE PARAGOLPES ROSTRO

03	95 551 416	01 LAR30 RMP 5477549	02/80 ▶	BANDE ZIERBAND DECORATIV STRIP BANDA DECORATIV NASTRO
04	75 416 420	02 CC CAOUTCHOUC RMP 5477549		BUTEE DE CAPOT HAUBENANSCHLAG BONNET BUFFER TOPE CAPO CUSCINETTO COF.
05	AZ 615 1	01 G-		SUPPORT HALTER BUMPER BRACKET SOP.PARAG AV SUPPORTO
06	AZ 615 1 A	01 D-		-
06	5 400 508	02 DIAM 7X1,00-15		VIS TCB SCHRAUBE CAPSCREW TORNILLO TCB VITE
07	79 03 101 771	06 DIAM7X100-20 RMP 23719319		VIS TH SCHRAUBE CAPSCREW TORNILLO TH VITE
08	79 03 058 011	12 DIAM 7,2X14,2-1,4		RONDELLE CONIQU KONUSSCHEIBE SPRING WASHER ARANDELA RONDELLA CONICA
09	79 03 037 006	06 HE 5X0,80		ECROU A EMBASE MUTTER NUT WITH BASE TUERCA CON BASE DADO A BASETTA
10	79 03 032 036	06 HE 7X1,00-5,5 RMP 25261029		ECROU MUTTER NUT TUERCA DADO
11	26 158 209	06 DIAM 7 X 1,00 RMP 25261029		

.../...

**PARE-CHOCS AVANT**  
**VORDERE STOSSSTANGE**  
**FRONT BUMPER**  
**PARACHOQUES DELANTEROS**  
**PARAURTI ANTERIORI**

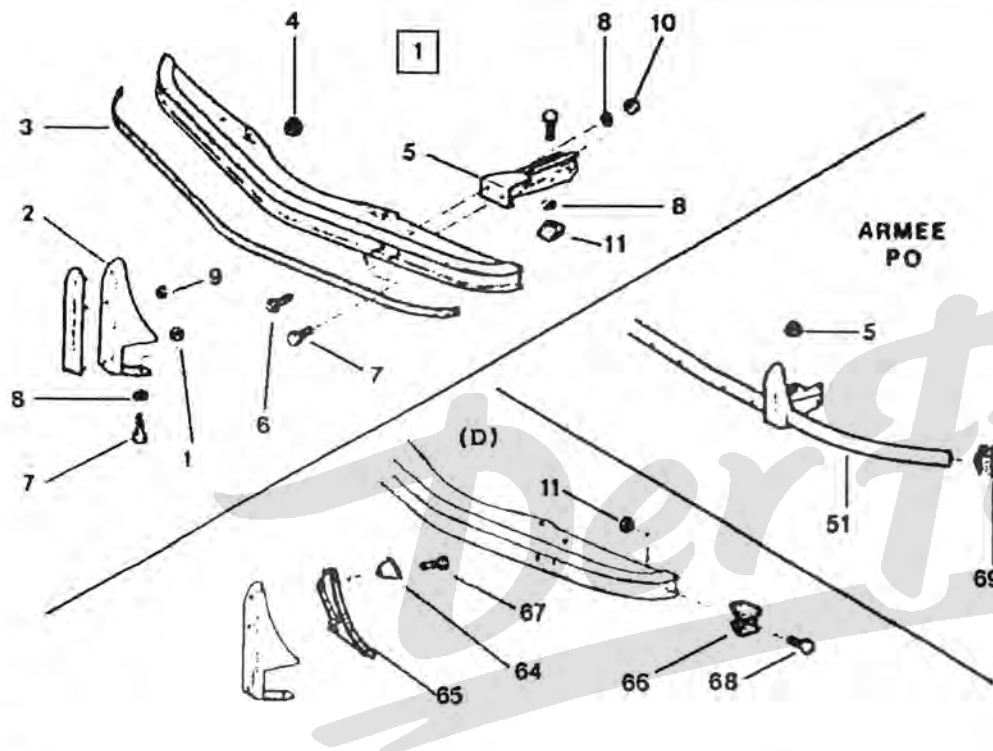

1117

[6/89]

06.6171.10

Z6171100

61	79 03 037 006	02	HE 5X0,80 -(D)	01/80 ▶	ECROU A EMBASE MUTTER NUT WITH BASE TUERCA CON BASE DADO A BASETTA
64	AZ 615 18	02	-(D)	11/80 ▶	EMBOUT ENDSTUECK SOCKET TOOL TERMINAL TERMINALE
65	95 561 036	02	-(D)	11/80 ▶	-
66	95 561 034	02	-(D)	11/80 ▶	-
67	5 501 036	02	-(D)	1516 ▶	AGRAFE KLAMMER CLIP GRAPA AGRAFE
68	24 683 369 RP 24708009	02	TFB 5X16 -(D)	1516 ▶	VIS TFB METALISCHRAUBE METAL SCREW TORNILLO METAL VITE
69	95 589 960	01	PON 353X128 -(I)		SUPPORT HALTER LICENSE BRACKET SOPORTE SUPPORTO

**XT**

AK 615 4 E

01 -ARMEE -ATMOSPHERE  
POUSSIERES

PARE-CHOCS AV  
OHNE ZIERLEISTE  
FRONT BUMPER  
PARAGOLPES AV  
PARAURTI ANT.

15/02/91  
1117 06-6172-20  
PAGE : 1  
D10 ↓

**PARE-CHOC ARRIERE**  
HINTERE STOSSTANGE  
REAR BUMPER  
PARECHOQUES TRASEROS  
PARAURTI POSTERIORE

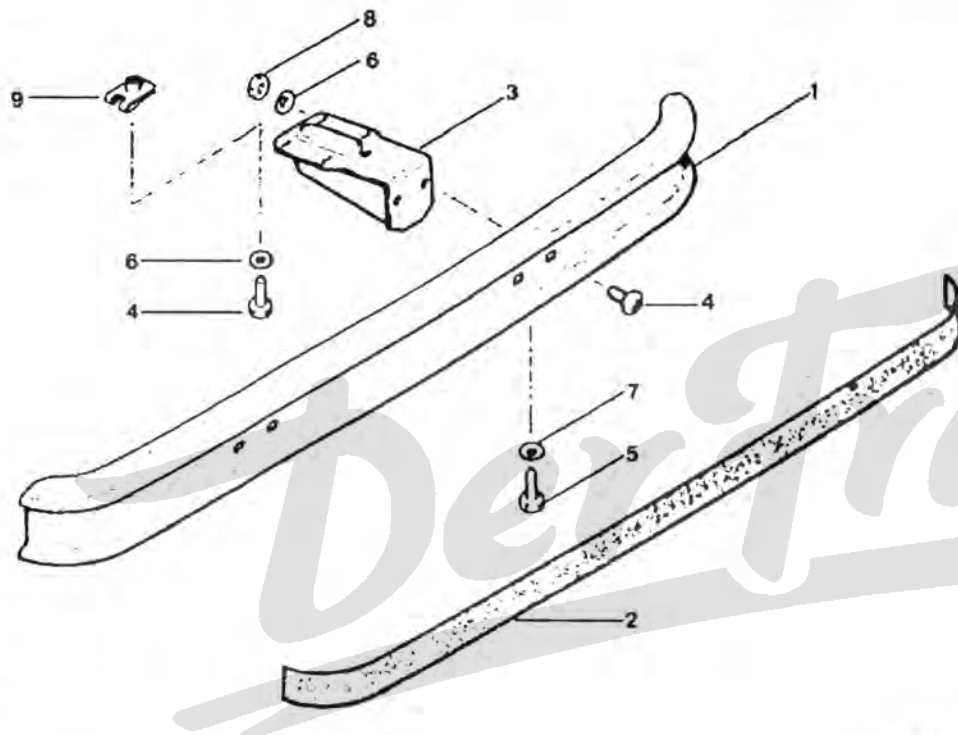

1114

S. 615.20  
Z6172200

01	95 624 962 VA	01	RMP	LAME PARE-CH.AV STANGE FRT BUMPER LEAF HOJA PARAURTI
02	95 551 416	01	LAR30 -SPECIALE RMP 5477549	BANDE ZIERBAND DECORATIV STRIP BANDA DECORATIV NASTRO
	5 476 981	01	LON 1330X52	-

03	AZ 615 288 A	02	-SPECIALE	SUPPORT HALTER BUMPER BRACKET SOP.FARAG AR SUPPORTO
04	5 400 508	04	DIAM 7X1,00-15	VIS TCB SCHRAUBE CAPSCREW TORNILLO TCB VITE
	79 03 101 769	04	DIAM 7X45 -ATMOSPHERE POUSSIERES RMP 23450319	VIS TH SCHRAUBE CAPSCREW TORNILLO TH VITE
05	79 03 201 150	02	DIAM 8X1,25 - 20 RMP 7703001333	-
	79 03 101 771	02	DIAM7X100-2 -SPECIALE RMP 23719319	-
	79 03 058 029	12	DIAM 7,2 X14,2X1,4	RONDELLE CONIQU KOHUSSCHEIBE SPRING WASHER ARANDELA RONDELLA CONICA
07	79 03 058 030	02	DIAM 8X18X1,4	RONDELLE A DENT ZAHNSCHEIBE SPRING WASHER ARANDELA RONDELLA DENTAT
	79 03 058 011	02	DIAM 7,2X14,2-1,4 -SPECIALE RMP 22904019	RONDELLE CONIQU KOHUSSCHEIBE SPRING WASHER ARANDELA RONDELLA CONICA
08	79 03 032 036	04	HE 7X1,00-5,5 RMP	ECROU MUTTER NUT TUERCA DADO
09	26 158 209	08	DIAM 7 X 1,00	-

.../...

15/02/91  
 1117 06-6172-20  
 PAGE : 2  
 D09 ↓

**PARE-CHOC ARRIERE**  
 HINTERE STOSSTANGE  
 REAR BUMPER  
 PARECHOQUES TRASEROS  
 PARAURTI POSTERIORE

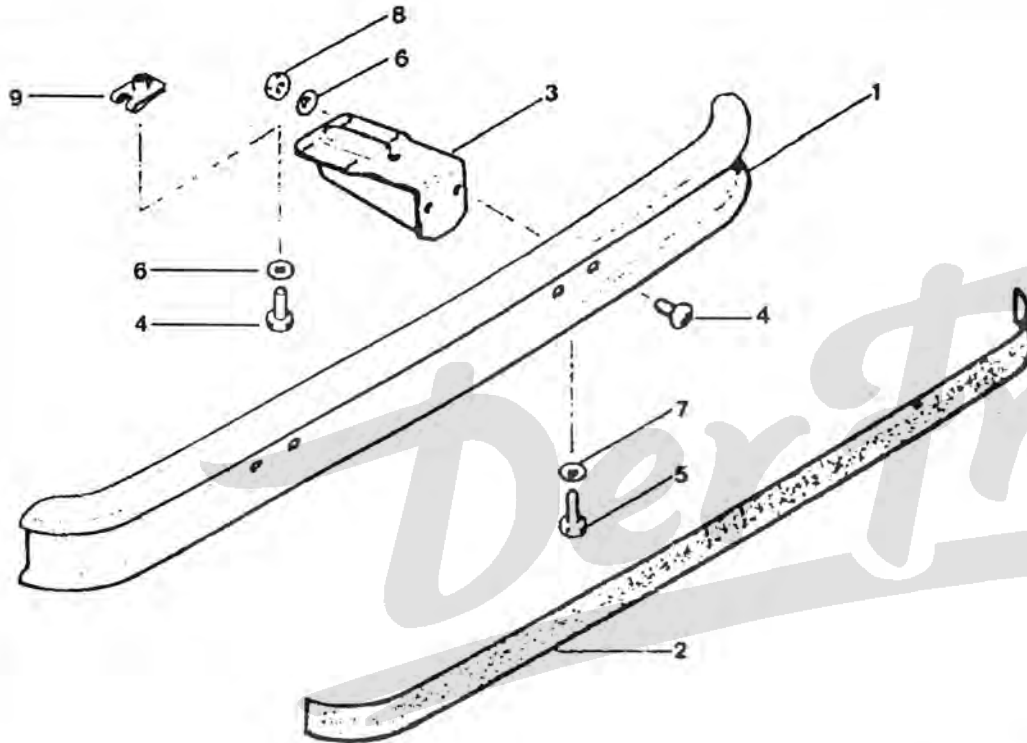

1114

0.615.20  
 Z6172200

**XT**

61	79 03 032 006	04	DIAM 5X0,80 -(CH)	ECROU MUTTER NUT TUERCA DADO
62	79 03 056 005	99	DIAM 5,3X9,4 -(CH)	RONDELLE A DENT ZAHNSCHEIBE SPRING WASHER ARANDELA RONDELLA DENTAT
63	95 561 035	02	-(D) 1516 ▶	EMBOU ENDSTUECK LATERAL BLADE TERMINAL GHIERA
64	24 683 369 RP 24708009	04	TFB 5X16 -(D) 1516 ▶	VIS TFB METALISCHRAUBE METAL SCREW TORNILLO METAL VITE
60	79 03 201 015	04	TH 5X0,80X30 -(CH) RMP 7903101059	VIS TH SCHRAUBE CAPSCREW TORNILLO TH VITE

15/02/91  
 1117 06-6424-10  
 PAGE : 1  
 D08 ↓

**DEGIVRAGE - CHAUFFAGE**  
 HEIZUNG LUEFTUNG  
 HEATING VENTILATION  
 CALEFACCION AIREACION  
 RISCALDAMENTO AERAZIONE

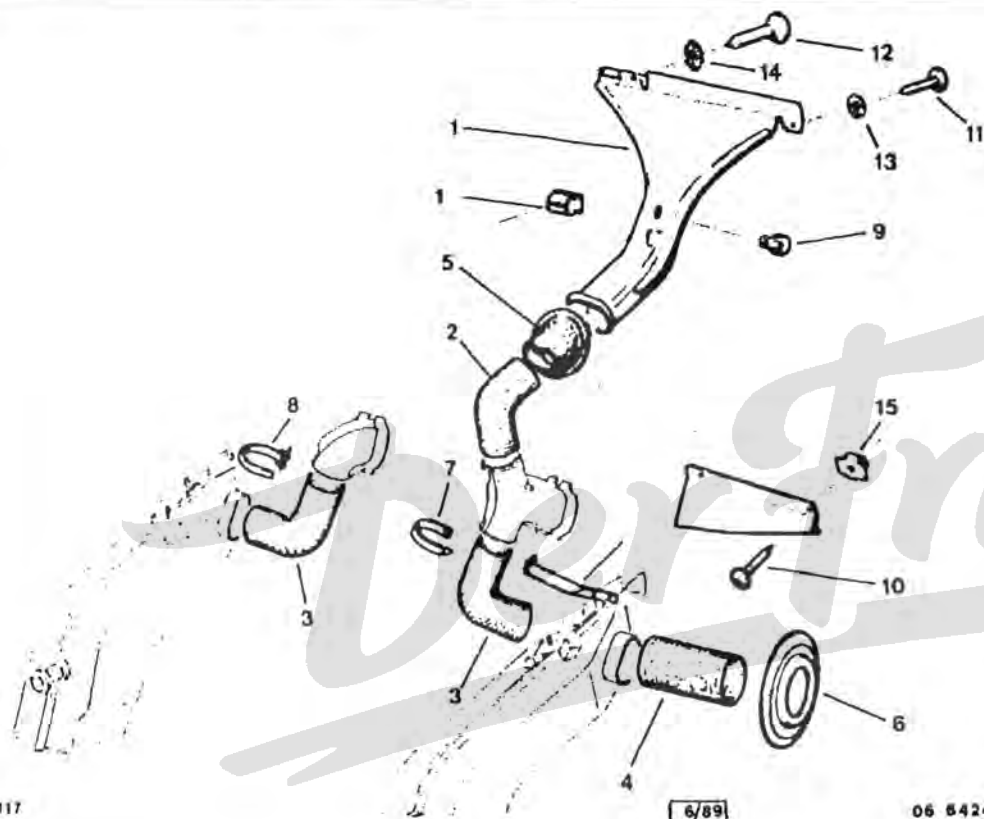

1117

[6/89]

06 6424.10  
 Z6424100

04	AK 643 144 B	02	DIAM 80X88X140 RMP 5426067-5426066	2061 ▶	TUBE CHAUFFAGE ROHR SOCKET TUBE TUBO TUBO PRESA
05	5 487 825	01	CAOUTCHOUC		GAINÉ ABDECKBLENDE AIR PULLER HOSE CONDUCTO GUAINA
06	AY 643 155	02	CAOUTCHOUC		JOINT DICHTUNG AIR PULLER SEAL JUNTA GUARNIZIONE
07	26 142 309	01	CAOUTCHOUC		COLLIER SCHELLE ADJUST COLLAR ABRAZADERA COLLARE
08	22 996 029 RP 7903083271	06	LON 605		-
09	95 632 552	02	RMP 5420549		BUTÉE CAOUTCHOUC ANSCHLAG RUBBER BUFFER TOPE GOMA REGGISPINTA
10	79 03 016 283	99	DIAM 4,8X13	07/79 ▶	VIS TOLE TCB BLECHSCHRAUBE TAPPING SCREW TORNILLO CHAPA VITE
11	79 03 016 208 RP 7903016414	99	DIAM 4,8X19 RMP 22303019		-
12	79 03 016 256	99	FB4-8X19		VIS TOLE TF BLECHSCHRAUBE TAPPING SCREW TORNILLO R CHAP VITE LAMIÉRA
13	79 03 056 003	99	DIAM 4,2 X 8		RONDELLE A DENT ZAHNSCHEIBE SPRING WASHER ARANDELA RONDELLA DENTAT

01 AZ 564 206 A

01

BUSE DEGIVRAGE  
 ENTFROSTERDUESE  
 DEFROSTER NOZZL  
 DIFUSOR ANTIVAH  
 CONDOTTO SBRINA

02 5 426 070

01 DIAM INT 44X81,5-230

CONDUIT DE BUSE  
 DUESENFUEHRUNG  
 NOZZLE CHANNEL  
 CONDUCTO  
 CONDOTTO UGELLO

03 95 581 534

01 DIAM INT 50X92X420  
 RMP 5426067-5426066

2061 ▶

-

.../...

15/02/91  
 1117 06-6424-10  
 PAGE : 2  
 D07 ↓

**DEGIVRAGE - CHAUFFAGE**  
 HEIZUNG LUEFTUNG  
 HEATING VENTILATION  
 CALEFACCION AIREACION  
 RISCALDAMENTO AERAZIONE

**XT**

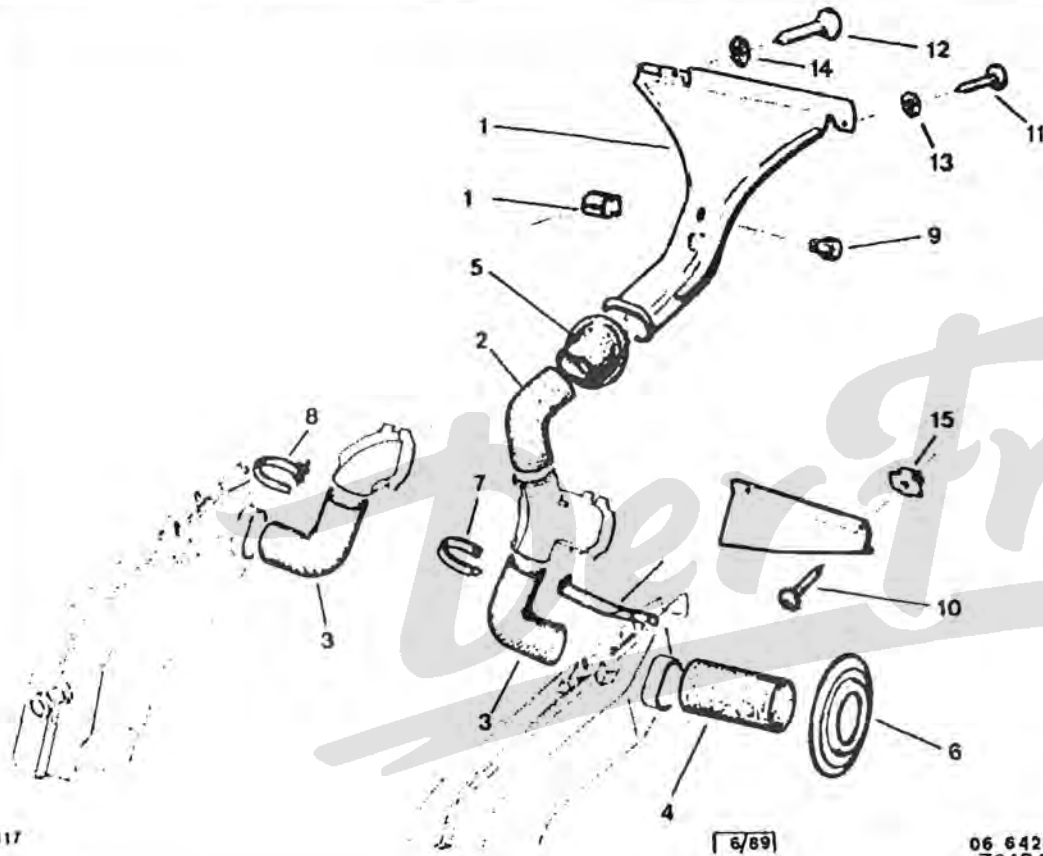

1117

[ 6/89 ]

06 6424.10  
 Z6424100

51 AZ 564 206 A 02 -CAD

**BUSE DEGIVRAGE**  
 ENTFROSTERDUESE  
 DEFROSTER NOZZL  
 DIFUSOR ANTIVAH  
 CONDOTTO SBRINA

52 5 485 487 01 -CAD

**CONDUIT DE BUSE**  
 DUESENFUEHRUNG  
 NOZZLE CHANNEL  
 CONDUCTO  
 CONDOTTO UGELLO

54 5 485 488 01 -CAD

**CONDUIT**  
 LEITUNG  
 HEATER DUCT  
 CONDUCTO  
 CONDOTTO

56 5 487 825 02 CAOUTCHOUC  
 -CAD

**GAINE**  
 ABDECKBLENDE  
 AIR PULLER HOSE  
 CONDUCTO  
 GUAINA

14 \* 79 03 057 066

99 DIAM 5

**RONDELLE CUVETT**  
 NAPFSCHEIBE  
 CUP WASHER  
 ARANDELA  
 RONDELLA PIATTE

15 26 157 129

01 CLIP

**ECROU**  
 MUTTER  
 NUT  
 TUERCA  
 DADO



15/02/91  
 1117 06-6430-20  
 PAGE : 1  
 D06 ↓

**COMMANDE VOLETS DE CHAUFFAGE - DEGIVRAGE**  
 HEIZ UND VELUEFTUNGSBETAETIGUNG-KLAPPEN  
 HEATING-VENTILATION CONTROLS AND SHUTTER  
 MANDO DE VENTANILLAS DE CALEFACCION  
 COMANDO E SPORTELLI RISCALDAMENTO-AERAZI

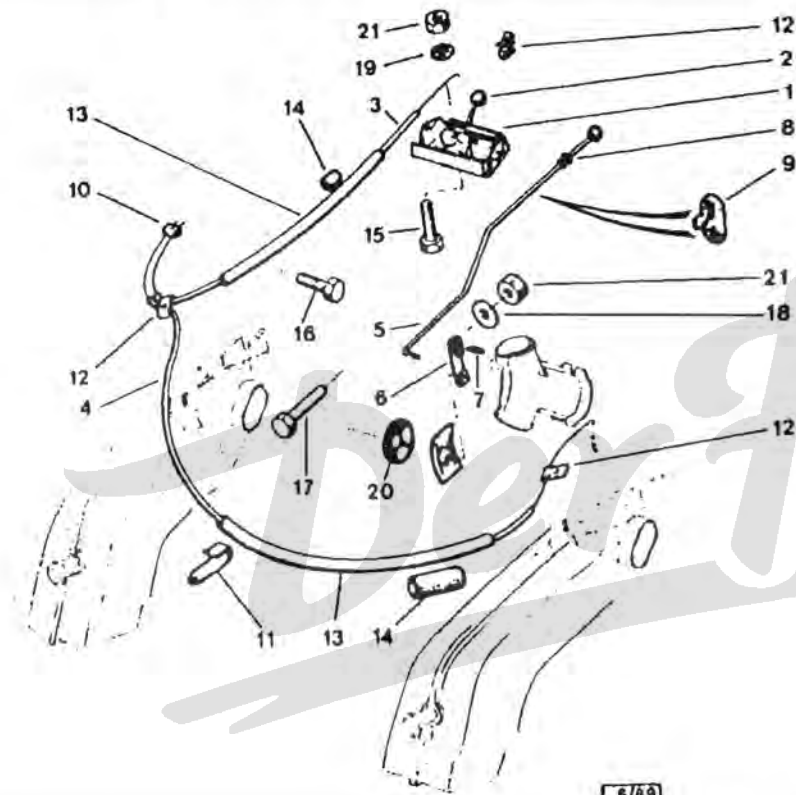

1117

6/89

06 6430-20  
 Z6430200

02	95 412 362 FXX	02	DIAM 16	POIGNEE GRIFF LEVER HANDLE POMO LEVA
03	95 557 784	01	LON 1400 RMP 5411272 DEO 1-5441571	1696 ▶ CABLE DE CDE BET -ZUG CONTROL CABLE CABLE MANDO LEVA
04	95 557 785	01	LON 985 RMP 5476948	1605 ▶ -
	95 557 782	01	LON 865	1606 ▶ -
05	96 995 271	01	RMP AZ644271A	TIGE DE CDE BETAETIG.STANGE CONTROL ROD VARILLA MANDO ASTA COMANDO
06	AZ 644 115	01		LEVIER HEBEL LEVER PALANCA LEVA
07	AZ 644 89	01		RESSORT DE CDE FEDER CONTROL SPRING MUELLE MOLLA
08	5 415 082 NFP	01		BAGUE DE CDE BETAETIG.-LAGER CONTROL BUSHING CASQUILLO MANDC BOCCOLA CDO
09	AZ 644 116	01	"NYLON"	BAGUE HALTERING GROMMET PASACABLES BOCCOLA
10	95 568 857	01	DIAM 4 X 0.70 RMP AZU644101	BAGUE DE CDE BETAETIG.-LAGER CONTROL BUSHING CASQUILLO MANDC BOCCOLA CDO

01	5 403 748	01	1606 ▶	SUPPORT DE CDE HALTER CONTROL BRACKET SOPORTE SUPPORTO
	95 558 263 RP 95624996	01	1758 ▶	-
	95 578 908 RP 95624996	01	1759 ▶	-

.../.

15/02/91  
 1117 06-6430-20  
 PAGE : 2  
 D05 ↓

**COMMANDE VOIETS DE CHAUFFAGE - DEGIVRAGE**  
 HEIZ UND VELUEFTUNGSBETAETIGUNG-KLAPPEN  
 HEATING-VENTILATION CONTROLS AND SHUTTER  
 MANDO DE VENTANILLAS DE CALEFACCION  
 COMANDO E SPORTELLI RISCALDAMENTO-AERAZI

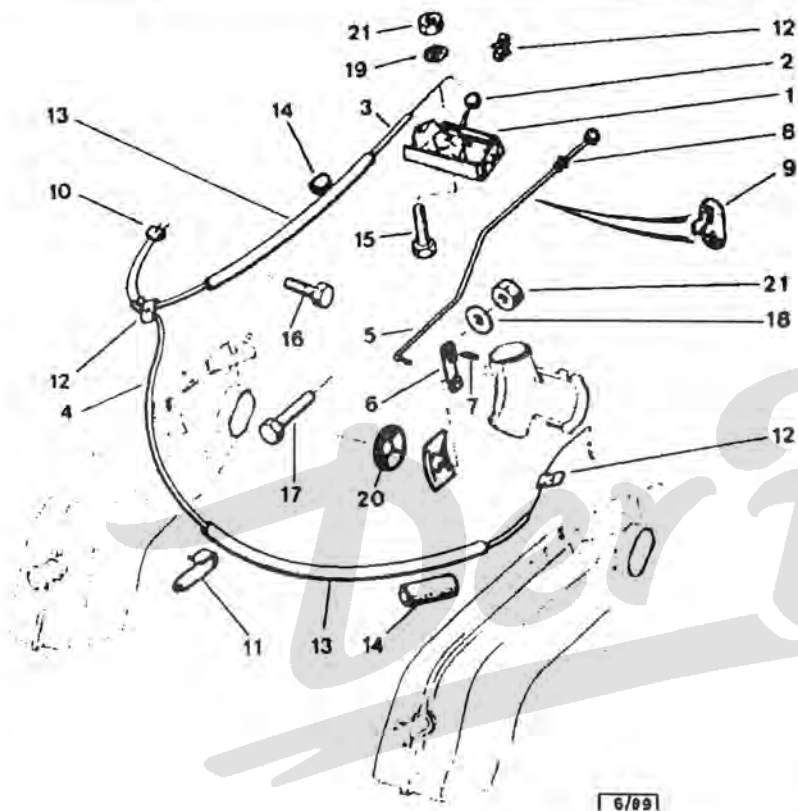

1117 6/89 06 6430.20  
Z6430200

11	AK 644 63	01	PATTE HALTELASCHE SUPPORT LUG SOPORTE STAFFA
12	5 441 571	01	.
13	AY 644 121	02	5X100X500 CAOUTCHOUC <span style="margin-left: 20px;">▶ 3601</span> GAINÉ ANTIBRUIT HUELLE G-DAEMPF SHEATH VAINA GUAINA ANTIRUM.

14	75 416 426	02	GAINÉ DE CABLE ZUGSCHUTZHUELLE CONTROL SHEATH FUNDA DE CABLE GUAINA DEL CAVO
15	79 03 201 010	02	TH 5X0,8-10 RMP 7903101053 VIS TH SCHRAUBE CAPSCREW TORNILLO TH VITE
16	26 210 689	01	TH 4 X 8 RMP 7903101053
17	79 03 007 071	01	TCB 5X20 RMP 24535019 VIS TCB SCHRAUBE CAPSCREW TORNILLO TCB VITE
16	22 312 019 RP 7903053025	01	DIAM 5,5X9 RONDELLE PLATE FLACHSCHEIBE PLAIN WASHER ARANDELA PLANA RONDELLA PIATTA
19	79 03 056 005	02	DIAM 5,3X9,4 RONDELLE A DENT ZAHNSCHEIBE SPRING WASHER ARANDELA RONDELLA DENTAT
20	26 240 019	01	DIAM 4X11,5 RONDELLE PLATE FLACHSCHEIBE PLAIN WASHER ARANDELA PLANA RONDELLA PIATTA
21	79 03 032 006	02	DIAM 5X0,80 RI/MP 25259019 ECROU MUTTER NUT TUERCA DADO
51	DX 644 257 A	01	-CAD  <b>XT</b> CDE VOLET AERA. BETAETIGUNG. FLAP CONTROL MANDO TRAMPILLA COMANDO SPORTEL  .../...

15/02/91  
 1117 06-6430-20  
 PAGE : 3  
 D04 ↓

**COMMANDE VOIETS DE CHAUFFAGE - DEGIVRAGE**  
 HEIZ UND VELUEFTUNGSBETAETIGUNG-KLAPPEN  
 HEATING-VENTILATION CONTROLS AND SHUTTER  
 MANDO DE VENTANILLAS DE CALEFACCION  
 COMANDO E SPORTELLI RISCALDAMENTO-AERAZI

73

26 198 979

01

-CAD

AGRAFE  
 KLAMMER  
 HEATER CLIP  
 GRAPA  
 AGRAFE

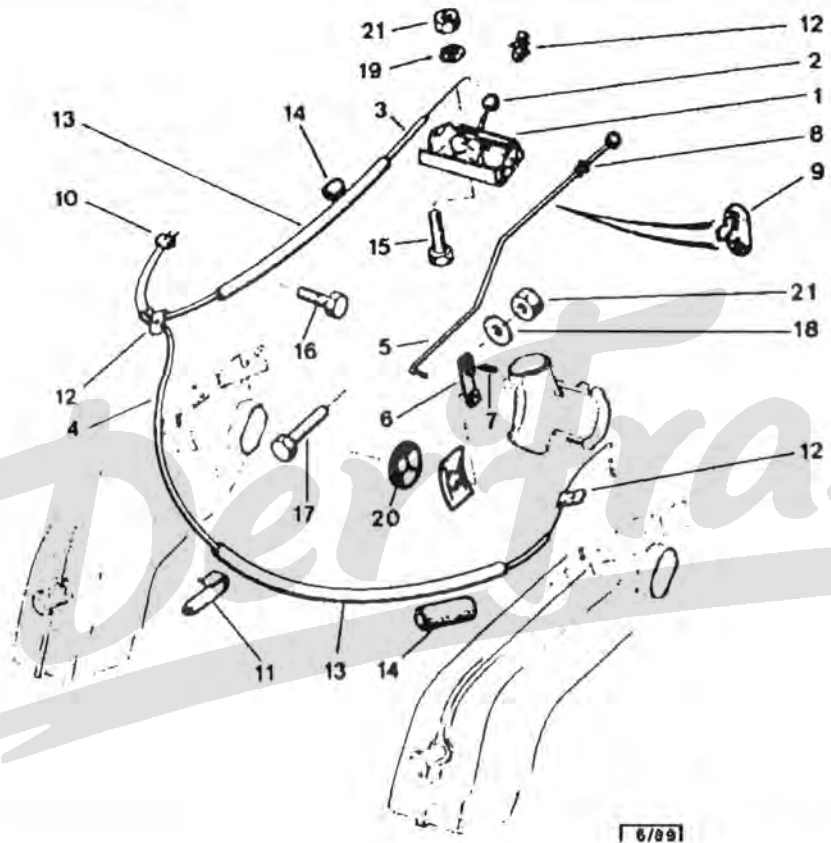

1117

6/89

06 6430.20  
 Z6430200

53	5 485 486	01 -CAD	CABLE DE CDE BET -ZUG CONTROL CABLE CABLE MANDO COMANDO SPORTEL
55	5 485 484	01 LON 300 -CAD	TIGE DE CDE BETAETIG.STANGE CONTROL ROD VARILLA MANDO ASTA COMANDO

**AERATION**  
 LUEFTUNG  
 VENTILATION  
 AERACION  
 AERAZIONE

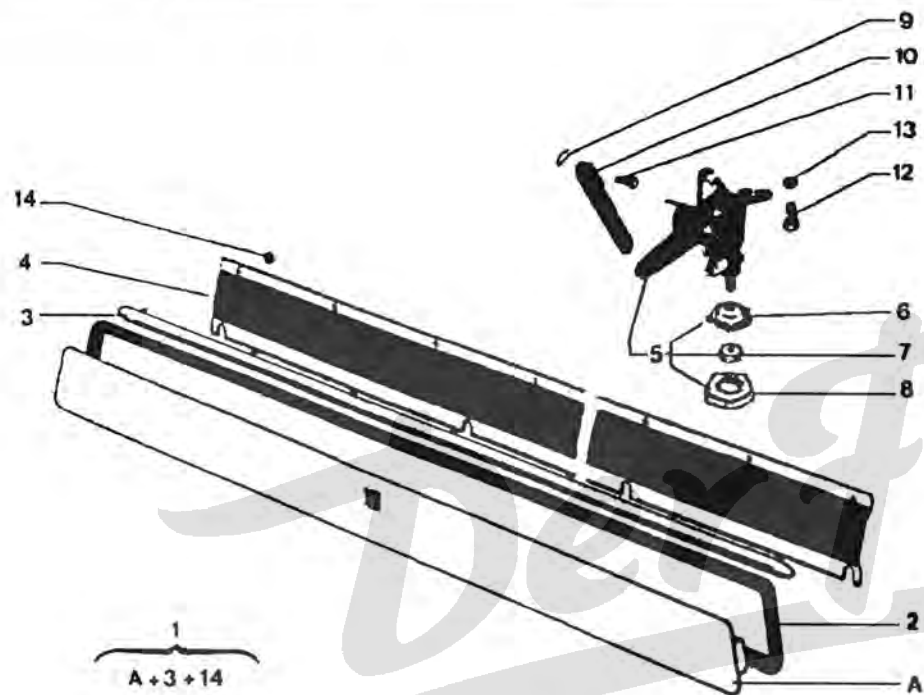

1117

06.5441.10

06.5441.10

Z6441109

02	AZ 644 281 A	01	LON 1X6X4	JOINT CAOUTCHOU GUMMIDICHTUNG RUBBER SEAL JUNTA GOMA GUARNIZIONE GOM
03	A 644 94	01		PROFILE ABSCHLUSSPROFIL FINISHER PANEL PERFIL PROFILO FINITUR
04	95 573 612	01	1681 ▶	GRILLE AERATION BELUEFT.GRILL VENTILAT GRILLE REJILLA GRIGLIA AEREAZ.
05	95 574 269	01	1759 ▶	CDE VOLET AERA. BETAETIGUNG FLAP CONTROL MANDO TRAMPILLA COMANDO SPORTEL
06	AZ 644 79	01	▶ 1760	BOUTON DE CDE BET.-KNOPF CONTROL BUTTON BOTON MANDO BOTTONE COMANDO
07	AZ 644 103	01	HE 5X0.95 ▶ 1760	ECROU MUTTER NUT TUERCA DADO
08	ZC 9804 104 U	01	CC	BOUTON DE CDE BET.-KNOPF CONTROL BUTTON BOTON MANDO BOTTONE COMANDO
09	5 420 466	02		EPINGLE SPANGE PIN GRUPILLA SPILO
10	AZ 644 66	01		LEVIER DE CDE HEBEL CONTROL LEVER PALANCA MANDO LEVA

.../...

11	5 503 179	01	ENS	VOLET AERATION BELUEFTERKLAPPE VENTILATOR FLAP TRAMPILLA AIREA SPORTELLO
12	95 607 331	01	LON 1020 LARG 71,5	JOINT DE VOLET KLAPPENDICHTUNG FLAP SEAL JUNTA TRAMPILLA GUARNIZ. SPORTEL

15/02/91  
 1117 06-6441-10  
 PAGE : 2  
 D02 ↓

**AERATION**  
 LUEFTUNG  
 VENTILATION  
 AERACION  
 AERAZIONE

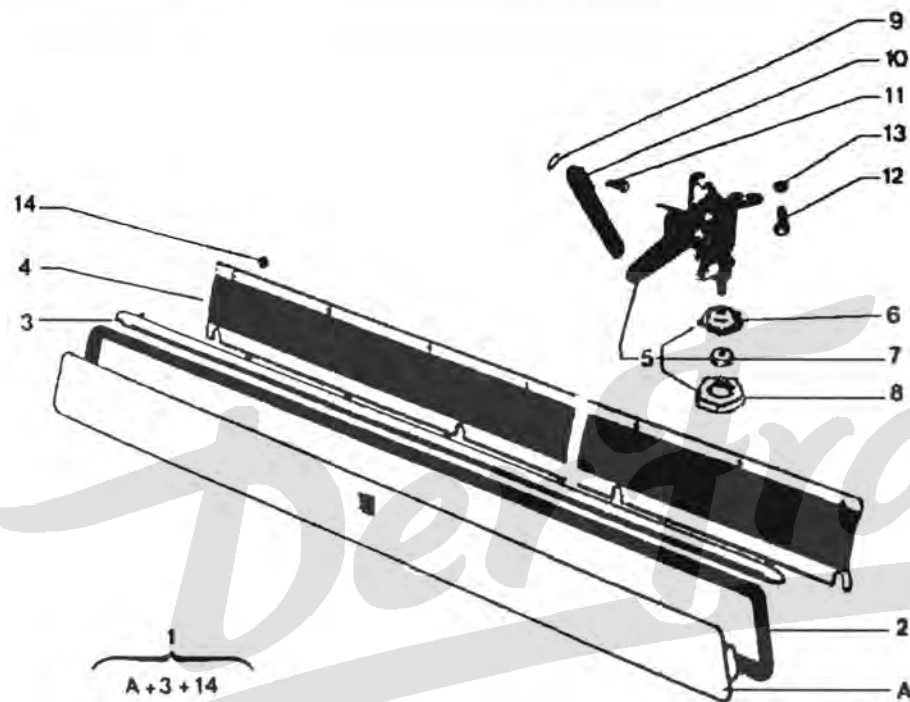

1117

13/89

06.5441.10

Z6441109

13	79 03 056 005	04	DIAM 5,3X9,4	RONDELLE A DENT ZAHNSCHEIBE SPRING WASHER ARANDELA RONDELLA DENTAT
14	79 03 032 001 RP 7903232001	12	HE 3X0,50	ECROU HEXAGONAL SECHSKANTMUTTER HEXAGONAL NUT TUERCA DADO ESAGONALE
11	AZ 644 113 A	02	LON 10	AXE FIX VOLET HALTEBOLZEN FLAP FIX SHAFT EJE TRAMPILLA PERNO FISS SPOR
12	79 03 201 130	04	DIAM 5 X 0,80 · 15	VIS TH SCHRAUBE CAPSCREW TORNILLO TH VITE

**PLATE-FORME**  
 RAHMEN  
 PLATFORM  
 PIATTAFORMA

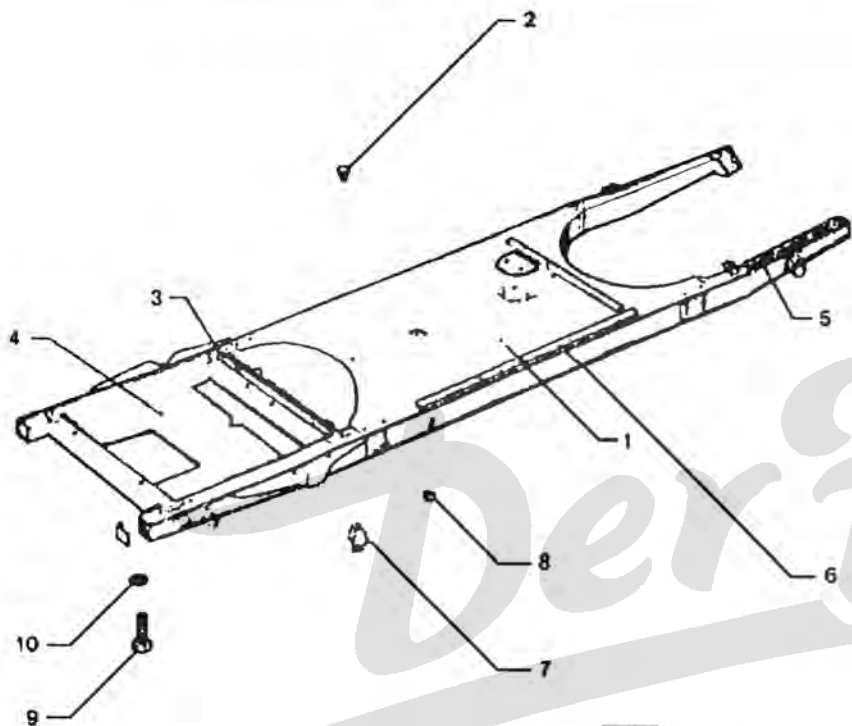

1117 6/89 06-7210.10  
 27210100

01	75 519 116	01	▶ 4558	CHASSIS RAHMEN KPL FRAME CHASSIS TELAIO ASSIEM
	96 073 854	01	SANS TOLE SOUSMOTEUR	-
			4557 ▶	
02	79 03 074 163	02	INF RMP 26130189	OBTURATEUR STOPFEN PLUG OBTURADOR OTTURATORE

03	95 607 328	01	CC-585-110 RMP A98292 - A98299	2765 ▶	ETANCHEITE ABDICHTUNG SEALING ESTANQUEIDAD TENUTA-
04	5 411 263	01			TOLE PROTECTION ABSCHIRMBLECH GUARD SHEET MET PANTALLA PROTEC LAMIERA
05	AZ 982 94	03	CC-585X25X10		ETANCHEITE ABDICHTUNG SEALING ESTANQUEIDAD TENUTA
06	95 607 329	01	G- 1320X25	2765 ▶	-
	95 607 330	01	D- 1320X25	2765 ▶	-
07	96 995 651	04	CAOUTCHOUC		AGRAFE KLAMMER CLIP GRAPA AGRAFE
08	AY 644 101	01	DIAM 7 "PLASTIQUE"		BOUCHON STOPFEN PLUG TAPON TAPPO
09	79 03 101 771	08	DIAM 7X100-20		VIS TH SCHRAUBE CAPSCREW TORNILLO TH VITE
10	79 03 058 011	06	DIAM 7,2X14,2-1,4		RONDELLE CONIQU KONUSSCHEIBE SPRING WASHE. ARANDELA RONDELLA CONICA
	79 03 058 029	02	DIAM 7,2 X14,2X1,4		-
11	95 577 955	01	"PAM"		ENS FIX CAISSE BEF.SAT BODY FIX KIT JUEGO FIX INS FISSAGIO

15/02/91  
 1117 06-7210-10  
 PAGE : 2  
 E01 ↑

PLATE-FORME  
 RAHMEN  
 PLATFORM  
 PLATAFORMA  
 PIATTAFORMA

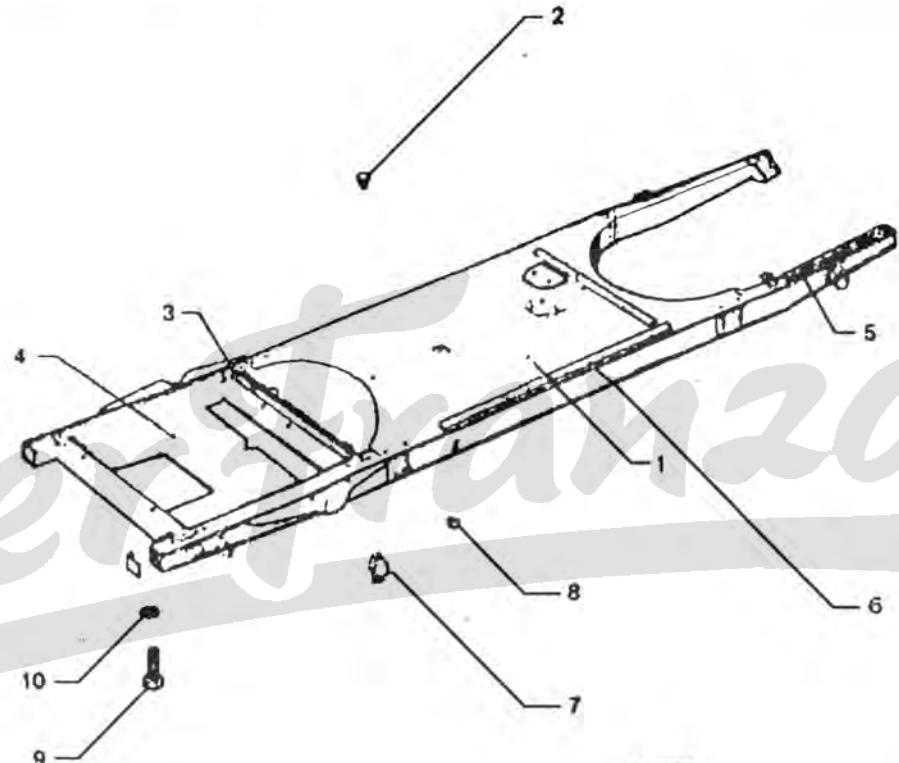

1117

6/89

06-7210.10

27210100

<b>XT</b>			
65	5 500 321	01 AV -(CH)	▶ 2061
	95 577 427	01 -(CH)	2062 ▶ -
			<b>INSONO MOT BV          BEKLEIDUNG          SOUND PROOFING          INSONORIZANTE          RIVESTIMENTO</b>

15/02/91  
1117 06-7210-20  
PAGE : 1  
E02 ↑

**PLATE-FORME - SOLUTION REPARATION**  
**RAHMEN - REPARATURTEILE**  
**PLATFORM - REPAIR PARTS**  
**PIATAFORMA - SOLUCION REPARACION**  
**PIATTAFORMA - SOLUZIONE RIPARAZIONE**

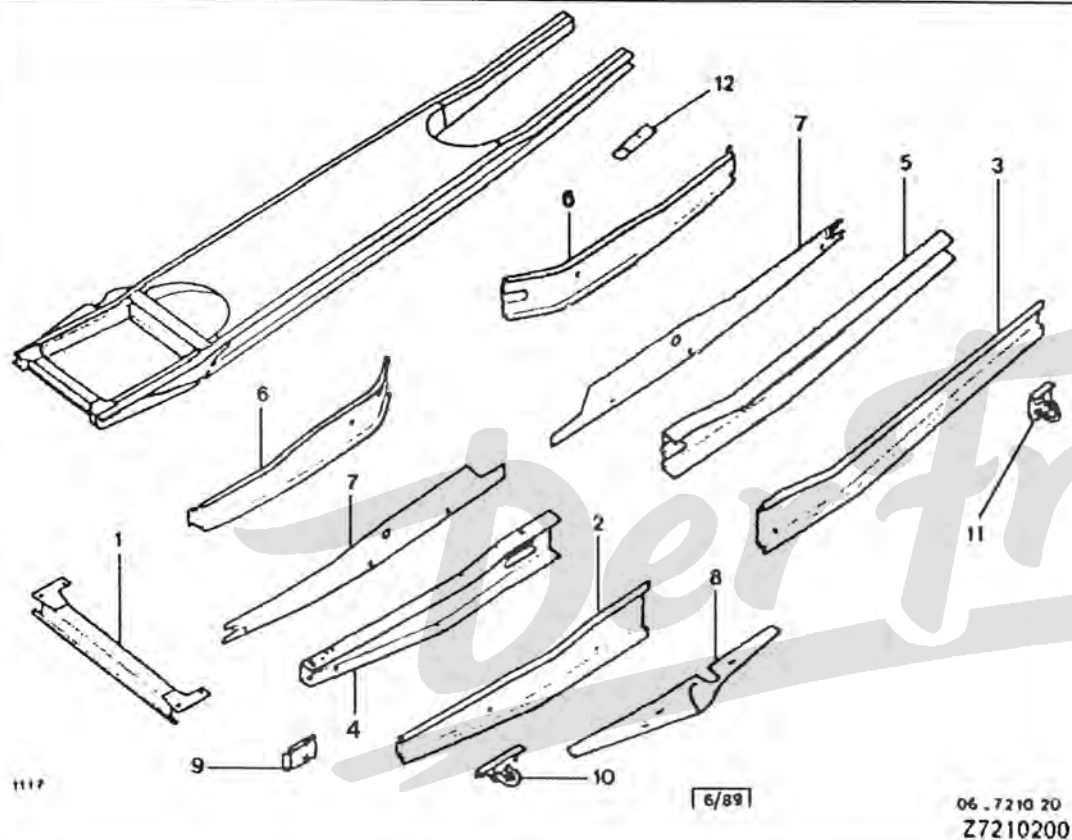

01	5 411 280	01	AV	TRAVERSE TRAVERSE CROSS RAIL TRAVIESA TRAVERSA
02	95 616 809	01	G- EXT-AV-LON 900	LONGERON LAENGSTRAEGER SIDEMEMBER LARGUERO LONGHERONE
	95 616 811	01	D- EXT-AV LON 900	

03	95 616 810	01	G- EXT-AR	LONGERON LAENGSTRAEGER SIDEMEMBER LARGUERO LONGHERONE
	95 616 812	01	D- EXT-AR-LON 1000	
04	95 616 813	01	G- INT-AV-LON 900	
	95 616 815	01	D- INT-AV-LON 900	
05	95 616 814	01	G- INT-AR-LON 1000	
	95 616 816	01	D- INT-AR-LON 1000	
06	5 410 480	01	G-EXT-AV	RENFORT VERSTAERKUNG SDMBR STIFFENER REFUERZO RINFORZO
	5 410 479	01	D-EXT-AV	
07	AW 721 93	04	INT	
08	96 995 259	01	G- LAT RMP AY721106A	TOLE DE LIAISON VERB-BLECH CONNECTG PLATE CHAPA DE UNION LAMIERA
	96 995 307	01	D-LAT RMP AY721104B	
09	AY 721 73	01	G-	ENTRETOISE ABSTANDSSTUECK SPACER JUEGO DISTANCIA DISTANZIALE
	AY 721 74	01	D-	
10	AZ 721 58	01	G- AV	SUPPORT HALTER CLAMP BRACKET SOPORTE BRIDA SUPPORTO
	AZ 721 58 A	01	D- AV	
11	A 721 57	01	G- AR	
	A 721 57 A	01	D- AR	

.../...



15/02/91  
 1117 06-7210-20  
 PAGE : 2  
 E03 ↑

**PLATE-FORME - SOLUTION REPARATION**  
**RAHMEN - REPARATURTEILE**  
**PLATFORM - REPAIR PARTS**  
**PIATTAFORMA - SOLUCION REPARACION**  
**PIATTAFORMA - SOLUZIONE RIPARAZIONE**

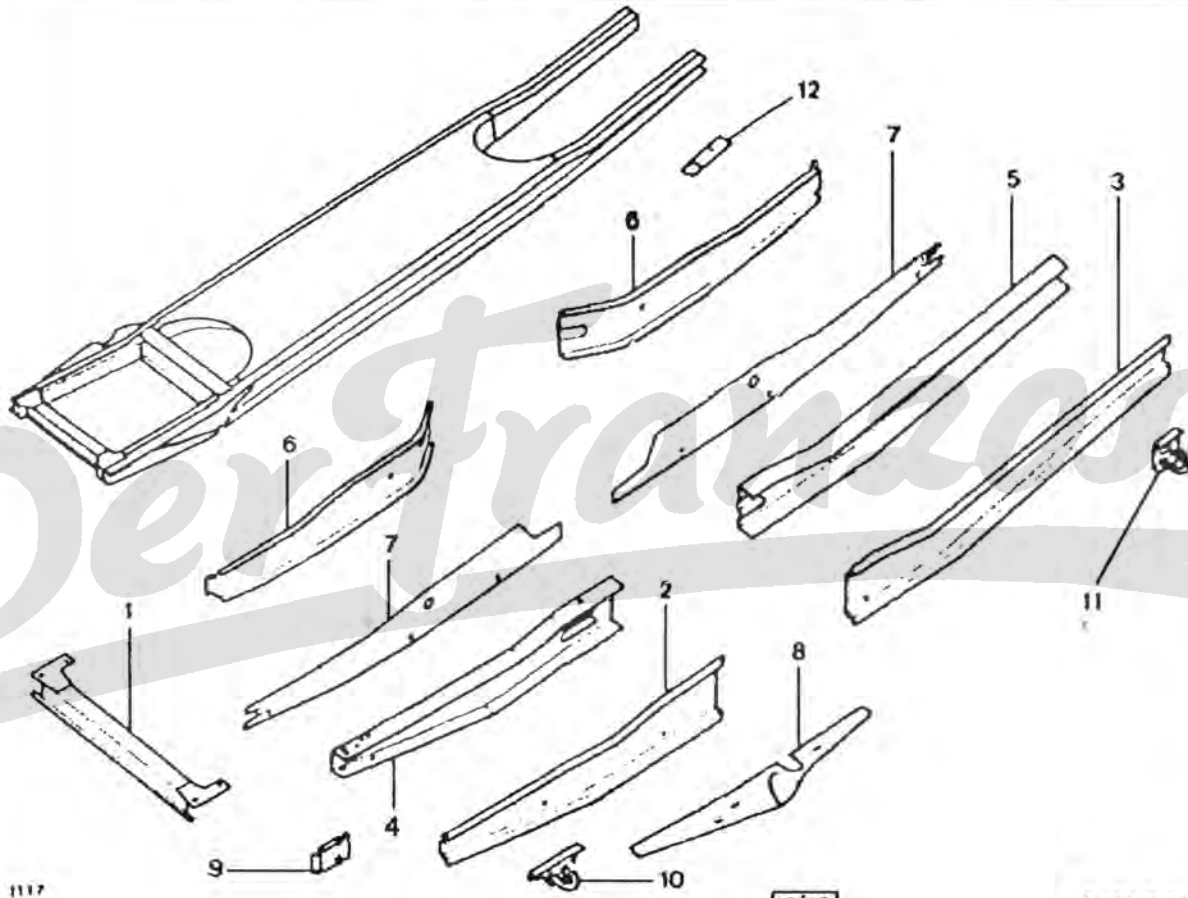

1117

6/89

06.7210.20  
 Z7210200

12	AZ 615 76	01 G. AR	EQUERRE SUPPORT HALTEWINKEL MOUNTING BRACKT ESCUADRA SQUADRA SUPPORT
	AZ 615 76 A	01 D. OR	-

JMERO	SOUS-GROUPE	REP	NUMERO	SOUS-GROUPE	REP	NUMERO	SOUS-GROUPE	REP	NUMERO	SOUS-GROUPE	REP
400 508	06-6171-10	06	24 683 369	06-6172-20	64	95 541 377		12		06-2421-10	82
	06-6172-20	04		06-6171-10	68	95 544 253	06-2421-10	08	95 624 964	06-6171-10	02
400 918	06-1730-10	07	26 130 489	06-2421-10	10	95 548 494	06-1830-10	04	95 632 552	06-6424-10	09
402 981	06-1750-11	03	26 139 009		13	95 548 497		04	96 073 854	06-7210-10	01
	06-1750-10	03	26 142 309	06-6424-10	07	95 551 416	06-6171-10	03	96 995 259	06-7210-20	08
403 748	06-6430-20	01	26 157 109	06-2421-10	26		06-6172-20	02	96 995 271	06-6430-20	05
410 471	06-1848-20	18	26 157 129	06-6424-10	15	95 557 782	06-6430-20	04	95 995 307	06-7210-20	08
410 472		17	26 158 209	06-6172-20	09	95 557 784		03	96 995 620	06-1750-11	07
410 479	06-7210-20	06		06-6171-10	11	95 557 785		04		06-1750-10	07
410 480		06	26 158 259	06-2421-10	28	95 558 263		01	96 995 651	06-7210-10	07
411 283	06-7210-10	04	26 158 299	06-1848-20	07	95 561 034	06-6171-10	66	A 173 8	06-1730-10	02
411 280	06-7210-20	01	26 192 059	06-2421-10	24	95 561 035	06-6172-20	63	A 175 4 A	06-1750-10	05
412 295	06-1750-10	10	26 192 349	06-1730-10	19	95 561 036	06-6171-10	65		06-1750-11	05
	06-1750-11	10	26 198 979	06-6430-20	73	95 568 857	06-6430-20	10	A 251 1 A	06-2421-10	29
415 082	06-6430-20	08	26 210 689		16	95 573 482	06-2421-10	08	A 644 94	06-6441-10	03
420 486	06-6441-10	09	26 231 249	06-1730-10	06	95 573 483		09	A 721 57	06-7210-20	11
428 070	06-6424-10	02	26 234 279		09	95 573 612	06-6441-10	04	A 721 57 A		11
429 093	06-1830-10	02	26 240 019	06-6430-20	20	95 574 269		05	AK 251 87 A	06-2421-10	03
441 571	06-6430-20	12	75 418 420	06-6171-10	04	95 577 224	06-2421-10	52	AK 615 4 E	06-6171-10	51
475 158	06-1330-10	50	75 418 428	06-6430-20	14	95 577 427	06-7210-10	65	AK 643 144 B	06-6424-10	04
476 981	06-6172-20	02	75 420 175	06-2421-10	12	95 577 955		11	AK 644 63	06-6430-20	11
478 012	06-1750-10	04	75 420 467	06-1830-10	07	95 578 334	06-2421-10	65	AM 133 1	06-1330-10	01
	06-1750-11	04	75 478 985	06-2421-10	08	95 578 335		05	AM 174 221 A	06-1730-10	10
478 984	06-2421-10	05	75 478 988		06	95 578 336		06	AM 182 285 A	06-1848-20	15
478 995		05	75 506 357	06-1330-10	04	95 578 337		06	AM 182 6 B	06-1830-10	06
485 484	06-6430-20	55	75 506 358		05	95 578 338		04	AM 182 75	06-1848-20	66
485 486		53	75 510 647	06-1848-20	04	95 578 908	06-6430-20	01	AM 182 84		11
485 487	06-6424-10	52	75 510 643		54	95 579 170	06-2421-10	56	AM 183 48		13
485 488		54	75 515 547	06-1730-10	01	95 579 171		56	AM 183 81		05
487 825		56	75 515 913	06-2421-10	01	95 581 534	06-6424-10	03	AM 183 88		14
		05	75 518 015	06-1848-20	02	95 589 471	06-1750-11	02	AW 721 93	06-7210-20	07
490 413	06-1830-10	57	75 519 116	06-7210-10	01	95 589 960	06-6171-10	69	AY 182 101	06-1848-20	09
490 692	06-1750-11	02	75 520 510	06-1330-10	07	95 594 987	06-2421-10	17	AY 182 122		06
490 718	06-1830-10	03	75 521 611	06-1730-10	04	95 602 698	06-1330-10	03	AY 182 123		12
490 720		53	75 522 332		03	95 607 328	06-7210-10	03	AY 182 4	06-1830-10	05
500 321	06-7210-10	65	75 523 580	06-2421-10	04	95 607 329		08	AY 242 68	06-2421-10	80
501 038	06-6171-10	67	75 525 430	06-1848-20	01	95 607 330		06	AY 242 67		80
503 179	06-6441-10	01	75 527 203	06-1830-10	01	95 607 331	06-6441-10	02	AY 643 155	06-6424-10	06
503 759	06-1848-20	08	95 492 906	06-1750-10	01	95 607 711	06-2421-10	07	AY 644 101	06-1730-10	14
506 214	06-1750-11	08		06-1750-11	01	95 616 809	06-7210-20	02		06-7210-10	08
	06-1750-10	08	95 493 438		02	95 616 810		03	AY 644 121	06-6430-20	13
508 141	06-2421-10	02		06-1750-10	02	95 616 811		02	AY 721 73	06-7210-20	09
073 009	06-1730-10	12	95 495 448	06-1848-20	03	95 616 812		03	AY 721 74		09
1312 019	06-6430-20	18	95 496 097	06-1330-10	02	95 616 813		04	AY 9182 230 A	06-1830-10	08
1541 019	06-1848-20	25	95 499 045	06-2421-10	11	95 616 814		05	AYA 182 68	06-1848-20	58
1965 039	06-1830-10	13	95 540 150	06-1750-10	15	95 616 815		04	AZ 564 206 A	06-6424-10	51
1996 029	06-1750-10	11	95 540 834	06-2421-10	54	95 616 816		05			01
	06-6424-10	08	95 541 373	06-1750-10	13	95 623 757	06-2421-10	23	AZ 615 1	06-6171-10	05
1707 019	06-1750-11	12		06-1750-11	09	95 623 773	06-1848-20	21	AZ 615 1 A		05
1718 019	06-2421-10	14	95 541 375	06-1750-10	11	95 624 196	06-1730-10	11	AZ 615 18		64
1746 509	06-1730-10	15	95 541 376		06	95 624 273	06-1830-10	12	AZ 615 268 A	06-6172-20	03

B04 ↑

INDEX

Catalogue 1117

NUMERO	SOUS-GROUPE	REP	NUMERO	SOUS-GROUPE	REP	NUMERO	SOUS-GROUPE	REP
AZ 615 76	06-7210-20	12		06-1848-20	23			
AZ 615 76 A		12		06-6430-20	19			
AZ 644 103	06-6441-10	07		06-6441-10	13			
AZ 644 113 A		11	79 03 056 012	06-1330-10	12			
AZ 644 115	06-6430-20	06		06-1848-20	24			
AZ 644 116		09	79 03 056 017	06-1330-10	14			
AZ 644 281 A	06-6441-10	02	79 03 057 066	06-6424-10	14			
AZ 644 68		10	79 03 058 011	06-6172-20	07			
AZ 644 79		06		06-6171-10	08			
AZ 644 89	06-6430-20	07		06-2421-10	21			
AZ 721 58	06-7210-20	10		06-1730-10	17			
AZ 721 58 A		10		06-7210-10	10			
AZ 982 94	06-7210-10	05	79 03 058 027	06-2421-10	22			
DX 182 80 A	06-1848-20	16	79 03 058 029	06-6172-20	06			
DX 644 257 A	06-6430-20	51		06-7210-10	10			
HG 175 15	06-1750-10	07		06-1750-10	14			
ZC 9615 859 U	06-2421-10	27		06-1830-10	11			
ZC 9804 104 U	06-6441-10	08		06-1750-11	14			
ZC 9866 058 U	06-1750-10	08	79 03 058 030	06-6172-20	07			
	06-1750-11	08	79 03 058 043	06-1330-10	06			
ZC 9910 511 U	06-1730-10	05	79 03 074 163	06-7210-10	02			
79 03 001 603	06-1330-10	08	79 03 083 153	06-1730-10	13			
	06-1848-20	22	79 03 083 237	06-1848-20	10			
79 03 001 673	06-2421-10	18	79 03 083 250	06-1750-10	09			
79 03 001 708	06-1848-20	19	79 03 083 271	06-1750-11	11			
79 03 001 806	06-1730-10	16	79 03 101 757	06-1830-10	10			
79 03 007 071	06-6430-20	17	79 03 101 769	06-1750-11	13			
79 03 016 086	06-2421-10	17		06-6172-20	04			
79 03 016 208	06-6424-10	11	79 03 101 770	06-2421-10	18			
79 03 016 256		12	79 03 101 771	06-6171-10	07			
79 03 016 283		10		06-6172-20	05			
	06-2421-10	17		06-1830-10	09			
79 03 032 001	06-6441-10	14		06-7210-10	09			
79 03 032 006	06-6430-20	21	79 03 201 010	06-6430-20	15			
	06-6172-20	61	79 03 201 015	06-6172-20	60			
79 03 032 036		08	79 03 201 041	06-1848-20	20			
	06-6171-10	10	79 03 201 129	06-2421-10	19			
	06-1848-20	26	79 03 201 130		15			
	06-1330-10	10		06-1848-20	16			
79 03 032 249	06-1830-10	14		06-6441-10	12			
79 03 032 252	06-1330-10	11	79 03 201 138	06-2421-10	81			
79 03 037 006	06-6171-10	61	79 03 201 150	06-6172-20	03			
		09	79 03 201 173	06-1330-10	09			
79 03 044 001	06-2421-10	84	79 03 232 031	06-1548-20	27			
79 03 046 067		25	79 05 028 709	06-1730-10	05			
79 03 053 033		83	79 05 026 967		08			
79 03 053 352	06-1330-10	15	95 412 362 FXX	06-6430-20	02			
79 03 053 394		13	95 624 962 VA	06-6172-20	01			
79 03 055 019	06-2421-10	20	95 624 963 VA	06-6171-10	01			
79 03 056 003	06-6424-10	13						
79 03 056 005	06-6172-20	62						

15/02/91 1117 <b>TABLEAU DES VUES</b> <b>AUFSTELLUNG DER BILDER</b> <b>TABLE OF PICTURE</b> B01 ↑ <b>TABLA DE VISTAS</b> <b>TABELLA DELLE VEDUTE</b>	<b>GRUPE</b> <b>GROUP</b> <b>GROUP 07</b> <b>GRUPO</b> <b>GRUPPO</b>		<b>AILES AVANT</b> <b>VORDERE KOTLUEGEL</b> <b>FRONT WINGS</b> <b>ALETAS DELANTERAS</b> <b>PARAFANGHI ANT.</b>	8510-10	D11
<b>SOUS-GROUPE</b> <b>UNTERGRUPPE</b> <b>SUBGROUP</b> <b>SUBGRUPO</b> <b>SOTTOGRUPPO</b>	<b>NUMERO</b> <b>NUMMER</b> <b>NUMBER</b> <b>NUMERO</b> <b>NUMERO</b>	<b>VUE</b> <b>BILD</b> <b>PICTURE</b> <b>VISTA</b> <b>VEDUTA</b>	<b>AILES ARRIERE</b> <b>HINTERE KOTFLUEGEL</b> <b>REAR WINGS</b> <b>ALETA TRAS.</b> <b>PARAFANGHI POST.</b>	8515-20	D10
<b>CAISSE - PANNEAUX DE COTE</b> <b>KARROSSERIE</b> <b>BODY</b> <b>CORROCERIA</b> <b>CARROZZERIA</b>	0080-10	C02 C03 C04 C05	<b>DECORS ADHESIFS</b> <b>KLEBEVERZIERUNG</b> <b>ADHESIVE EMBELLISHMENT</b> <b>EMBELEFCIMIENTO ADHESIVO</b> <b>ABBELELIMENTO ADESIVO</b> - CHARLESTON - 007 - FRANCE 3 - DOLLY - COCORICO - ► 3584	8542-10 8542-20 8542-30 8542-40 8542-50	D09 D08 D07 D06 D05 D04 D03 D02
<b>ELEMENTS ARRIERE DE CAISSE</b> <b>HINTERE KAROSSERIE TEILE</b> <b>BODY REAR ELEMENTS</b> <b>ELEMENTOS TRAS</b> <b>ELEMENTI POSTE</b>	7460-10	C06 C07	<b>PLANCHE DE BORD</b> <b>ARMATURENDRETT-GERUST</b> <b>DASHBOARD</b> <b>PLANCHA ABORDO-ARMAZON</b> <b>CRUSCOTTO-ARMATURA</b>	8560-10	D01 E01
<b>PORTES LATERALES</b> <b>VORDERE TUEREN - RECHT</b> <b>FRONT DOORRS - RIDHT</b> <b>PUERTA LATERALE - DERECHA</b> <b>PORTIERA LATERALE - DESTRO</b>	8410-10	C08 C09 C10 C11	<b>SERRURES ET POIGNEES</b> <b>TUERSCHLOESSER UND GRIFFE</b> <b>LOCKS AND HANDLES</b> <b>CERRADURAS - MANECILLAS</b> <b>SERRATURE - MANIGLIE</b>	8611-10	E02 E03 E04 E05
<b>PORTE DE COFFRE</b> <b>HECKKLAPPE</b> <b>BOOT DOOR</b> <b>PUERTA DE MALETA</b> <b>PORTELLO COFANO BAULE</b>	8450-10	C12 C13 C14	<b>GLACES</b> <b>GLASSCHEIBEN</b> <b>GLASSES</b> <b>CRISTALES</b> <b>CRISTALLI</b>	9615-20	E06
<b>ARMATURE DE VOLET ARRIERE</b> <b>ARMATURE HECKKLAPPE</b> <b>BOOT DOOR FRAME</b> <b>ARMADURA DEPUERTA DE MALETA</b> <b>ARMADURA POSTELLO BAULE</b>	8453-20	C15 D15	<b>GLACES - ENCADREMENT AVANT</b> <b>VORDERE TUERFENSTER</b> <b>FRONT DOOR WINDOWS</b> <b>VENTANAS DE PUERTAS DELANTERAS</b> <b>FINESTRE PORTIERE ANT.</b>	9616-10	E07 E08 E09
<b>CAPOT</b> <b>MOTORHAUZE</b> <b>BONNET</b> <b>CAPO</b> <b>COFANO MOTORE</b>	8501-10	D14 D12 D12			

15/02/91  
1117 07-0080-10  
PAGE : 1  
C02 ↑

**CAISSE - PANNEAUX DE COTE**  
KARROSSERIE  
BODY  
CORROCCERIA  
CARROZZERIA

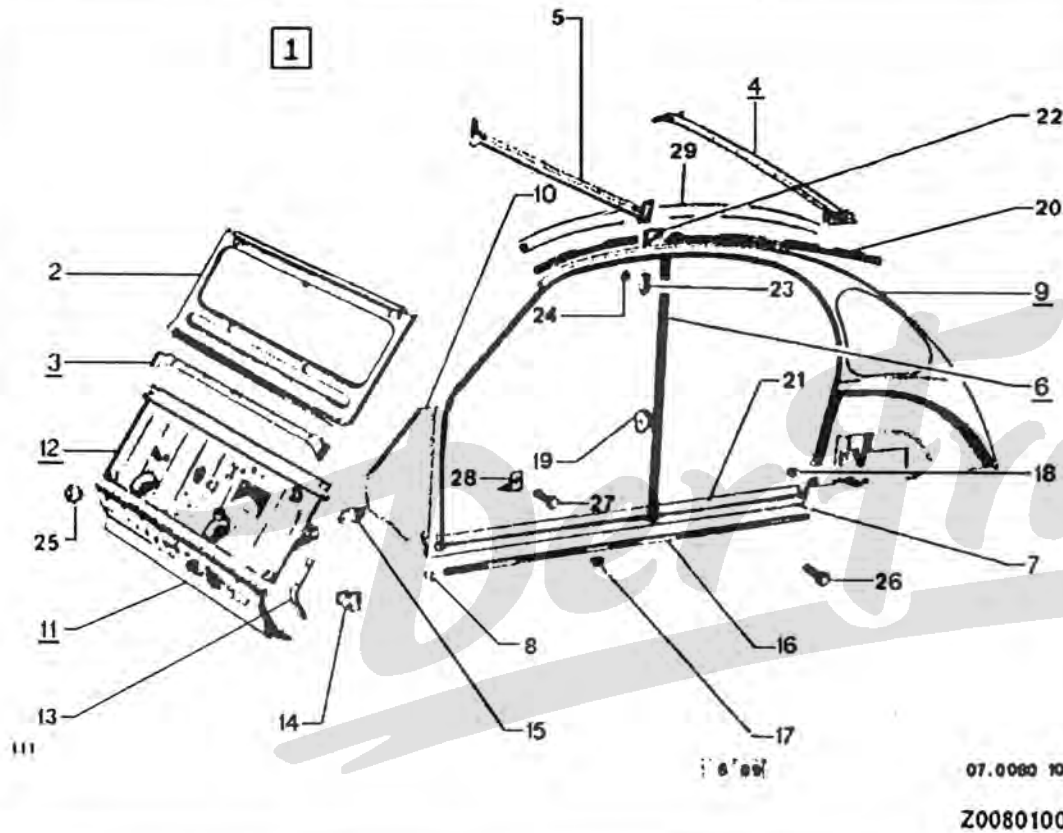

07.0080 10

20080100

01	95 595 539	01	RMP 75525904 - 95576409 - 75514347	2426 ▶	CAISSE EN BLANC KARROSSERIE BODY IN WHITE CORROCCERIA SCOCCA
02	5 402 260	01			BAIE PARE-BRISE SCHEIBENRAHMEN WINDSCRN PANEL MONTANTE PARAB. QUADRO PARABR.

03	A 813 87	01		TRAVERSE INF UNTERE TRAVERSE LWR CROSSMEMBER TRAVIESA INF TRAVERSA INF
04	5 403 085	01	AR	TRAVERSE AR HINT TRAVERSE RR CROSSMEMBER TRAVIESA AR TRAVERSA POST.
05	5 455 442	01	CENT	TRAVERSE SUP OBERE TRAVERSE UPPER CROSSMEMB TRAVIESA SUP TRAVERSA SUP
06	5 434 286	01	G.	PIED CENTRAL MITTELPFOSTEN CENTRAL POST PILAR CENTRAL MONTANTE CENTR.
07	5 434 287	01	D.	-
07	5 500 614	01	G.	BRANCARD UNTERZUG SIDE CANT RAIL LARGUERO LATER. LONGARONE
08	5 500 615	01	D.	-
08	AZ 821 106 RP 7903074030	12		BOUCHON STOPFEN PLUG TAPON TAPPO
09	75 524 607	01	G.	PANNEAU DE COTE SEIT.VERSCHALUNG SIDE PANEL PANEL LATERAL FIANCATA
	75 524 608	01	D.	-
10	A 822 2	01	G. LAT	TOLE FERMTURE BLECH LOCKING PLATE CHAPA DE CIERRE LAMIERA
	A 822 2 A	01	D. LAT	- .../...

15/02/91  
1117 07-0080-10  
PAGE : 2  
C03 ↑

**CAISSE - PANNEAUX DE COTE**  
KARROSSERIE  
BODY  
CORROCCERIA  
CARROZZERIA

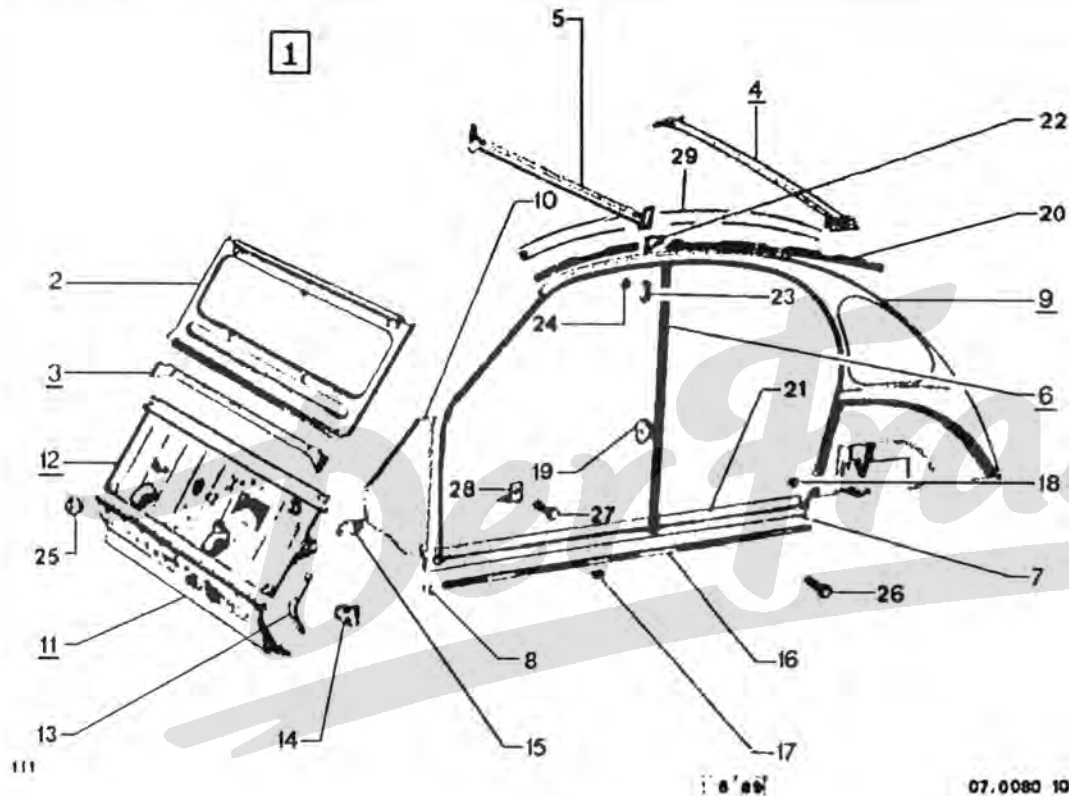

07.0080 10

Z0080100

11	95 576 406	01	RMP 75526406	1635 ▶	PLANCHER BODENBLECH FLOOR PISO PIANALE	13	AY 833 65	02		RENFORT VERSTAERKUNG STIFFENER REFUERZO RINFORZO
12	5 452 629	01			TABLIER BLECHWAND BULKHEAD TABLERO RIPIANO	14	AZ 841 79	01	G- INF	-
							AZ 841 79 A	01	D- INF	-
							AZ 841 82 B	01	G- SUP	-
							AZ 841 82 C	01	D- SUP	-
							95 551 416	02	LAR30 RMP 5477549	BANDE ZIERBAND DECORATIV STRIP BANDA DECORATIV NASTRO
							95 565 400	02	AVEC AGRAFES -CHARLESTON	ENJOLIVEUR ZIERLEISTE MOULDING EMBELLEDOR PROFILO
							A 854 18	12	-CHARLESTON	AGRAFE KLAMMER MOULDING CLIP GRAPA EMBELL AGRAFE
							75 412 366	04	DIAM 20	OBTURATEUR STOPFEN FLOOR PLUG OBTURADOR PISO TAPPO
							5 410 548	02	G-	SUPPORT CACHE FALLENHALTER STRIKER BRACKET SOPORTE SUPPORTO
							5 410 549	02	D-	
							95 593 161	01	G- 2426 ▶	GARNITURE BEZUG ROOF HEADLINING GUARNECIDO RIVESTIMENTO
							95 593 160	01	D- 2426 ▶	-

.../...

**CAISSE - PANNEAUX DE COTE**  
KARROSSERIE  
BODY  
CORROCERIA  
CARROZZERIA

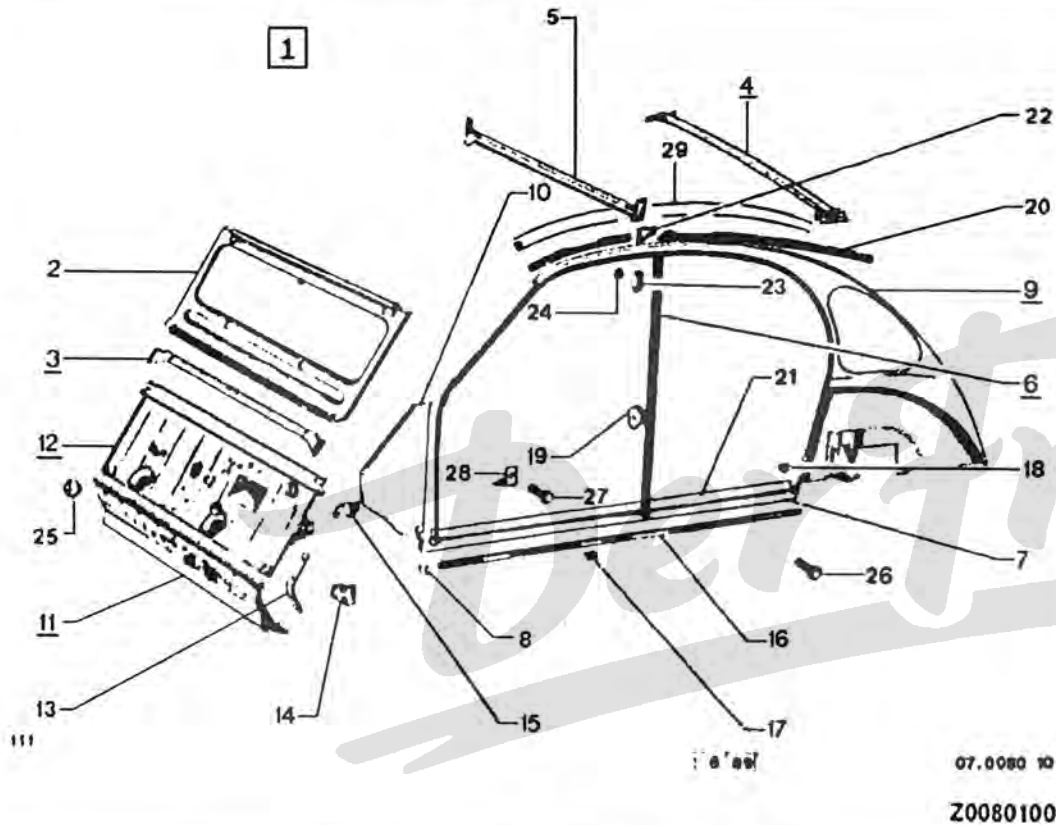

07.0080 10  
Z0080100

21	5 418 099	01	G-	TOLE FERMETURE BLECH LOCKING PLATE CHAPA DE CIERRE LAMIERA
	5 418 100	02	D-	-
22	5 403 269	02	SUP-AR	GOUSSET DE PIED STUETZBLECH CTRL POST GUSET REFUERZO PILAR RINFORZO PIANT.

23	5 403 969	02		BOITIER GEHAUSE BELT HOUSING CAJA PASO CINT SCATOLA
24	26 130 459	99	10,5X19,2X13 PLASTIQUE	OBTURATEUR STOPFEN PLUG OBTURADOR OTTURATORE
25	79 03 074 118	01	DIAM 15 "SPECIAL"	-
26	79 03 101 776	20	TH 7X1,00-50 RMP 23709319	VIS TH SCHRAUBE CAPSCREW TORNILLO TH VITE
	95 623 773	04	TH7X1,00-25	VIS SCHRAUBE SCREW TORNILLO VITE
27	79 03 101 771	16	DIAM7X100-20 RMP 23719319	VIS TH SCHRAUBE CAPSCREW TORNILLO TH VITE
28	26 158 299	04	CLIP 7X100	ECROU TOLE BLECHMUTTER SPEED NUT TUERCA CHAPA DADO LAMIERA
	26 158 209	20	DIAM 7 X 1,00	ECROU MUTTER NUT TUERCA DADO
29	AZ 821 125 A	02	-CHARLESTON -DOLLY	PROTECTEUR SCHUTZ PROTECTOR PROTECTOR PROTEZIONE
30	AZ 831 294 A	01	-ARMEE -ATMOSPHERE POUSSIERES	RENFORT VERSTAERKUNG STIFFENER REFUERZO RINFORZO

.../...

15/02/91  
1117 07-0080-10  
PAGE : 4  
C05 ↑

**CAISSE - PANNEAUX DE COTE**  
KARROSSERIE  
BODY  
CORROCERIA  
CARROZZERIA

**XT**

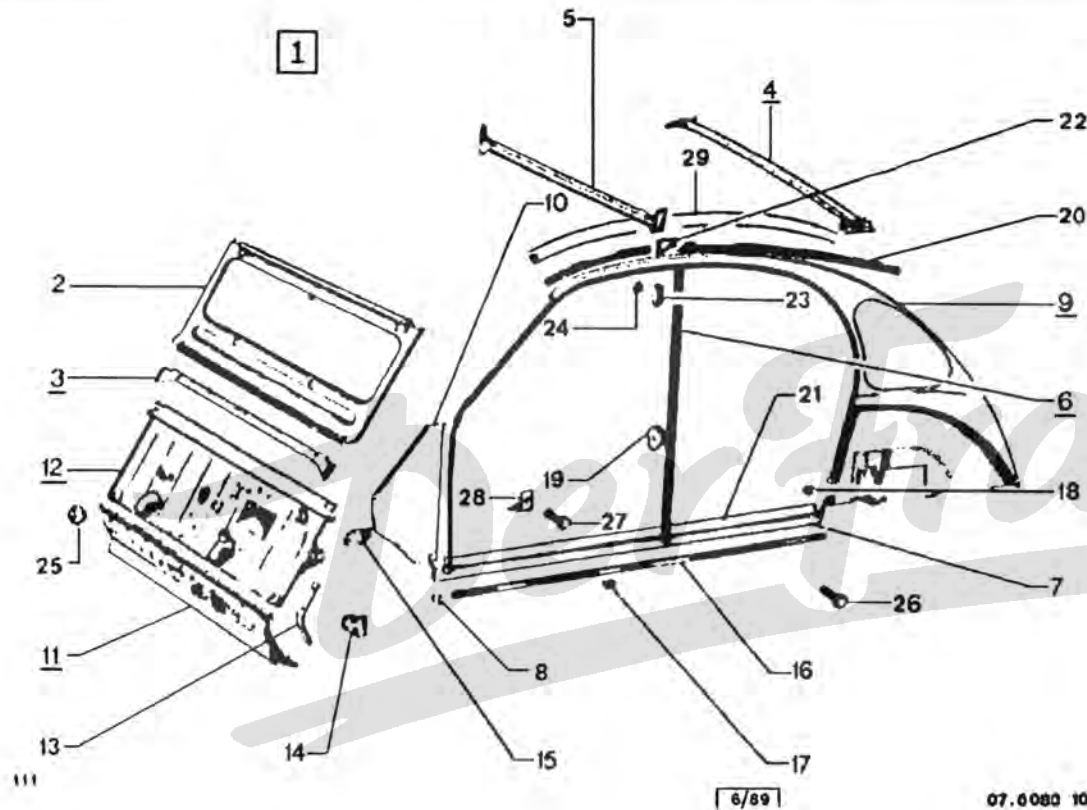

51	95 595 540	01	-CAD RMP 75525915 - 95576415	2426 ▶	CAISSE EN BLANC KARROSSERIE BODY IN WHITE CORROCERIA SCocca
53	5 485 506	01	INF -CAD		TRAVERSE INF UNTERE TRAVERSE LWR CROSSMEMBER TRAVIESA INF TRAVERSA INF
54	5 403 085	01	AR -(N) -(CH) -(SF) -(DK)		TRAVERSE AR HINT.TRAVERSE RR CROSSMEMBER TRAVIESA AR TRAVERSA POST.
56	5 458 865	01	G- -CAD		PIED CENTRAL MITTELPFOSTEN CENTRAL POST PILAR CENTRAL MONTANTE CENTR.
	5 458 866	01	D- -CAD		-
59	75 514 348	01	G- -(N) RMP 5464404		PANNEAU DE COTE SEIT.VERSCHALUN SIDE PANEL PANEL LATERAL FIANCATA
	75 514 349	01	D- -(N) RMP 5464405		-
61	95 576 413	01	-CAD RMP 75528259	2061 ▶	PLANCHER AV BODEN-VORN FRONT FLOOR PISO DELANTERO PIANALE ANT
62	5 485 496	01	-CAD		TABLIER BLECHWAND BULKHEAD TABLERO RIPIANO

31 79 03 072 083

15 \*POP\*DIAM 4X8  
-ARMEE -ATMOSPHERE  
POUSSIERES  
RMP 6187479

RIVET  
NIET  
RIVET  
REMACHE  
RIVETTO

32 DS 983 81

02 -ARMEE -ATMOSPHERE  
POUSSIERES

BOUCHON  
STOPFEN  
PLUG  
TAPON  
TAPPO



15/02/91  
 1117 07-7460-10  
 PAGE : 1  
 C06 ↑

**ELEMENTS ARRIERE DE CAISSE**  
 HINTERE KAROSSERIETEILE  
 BODY REAR ELEMENTS  
 ELEMENTOS TRAS.  
 ELEMENTI POSTE

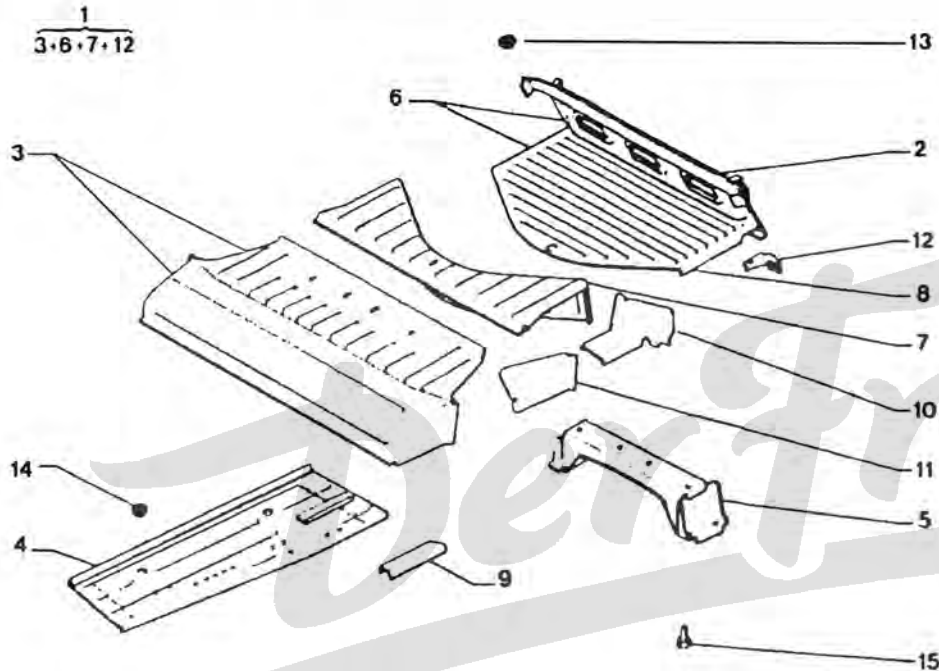

1114

7-742-10

Z7460100

01	5 403 073	01 AR	ENS DE PLANCHER BODENBLECH FLOOR ASSY CONJUNTO PISOS INS PIANALE
02	96 995 274	01 AR	PANNEAU AR HECKBLECH HINT. REAR PANEL PANEL TRASERO PANNELLO POST.

03	5 403 072	01	PLANCHER INTM ZWISCHENBODEN INTERMAD.FLOOR PISO INTERMADIO PIANALE INTERM.
04	96 995 263	01 G- LAT	PLANCHER AV BODEN-VORN FRONT FLOOR PISO DELANTERO PIANALE ANT
	96 995 264	01 D- LAT	-
05	5 403 067	01	TRVERSE TRVERSE CROSS RAIL TRAVIESA TRAVERSA
06	5 403 355	01	PLANCHER CHARGE LADERAUMBODEN LOAD FLOOR PISO DE CARGA PIANALE
07	5 419 320	01	PLANCHER INTM ZWISCHENBODEN INTERMAD.FLOOR PISO INTERMADIO PIANALE INTERM.
08	5 458 377	01 AR	PLANCHER CHARGE LADERAUMBODEN LOAD FLOOR PISO DE CARGA PIANALE
09	A 831 82	01 G-	TOLE FERMTURE BLECH LOCKING PLATE CHAPA DE CIERRE LAMIERA
	A 831 82 A	01 D-	-
10	A 831 87	01 G- LAT	-
	A 831 87 A	01 D- LAT	-
11	A 831 93	01 G- EXT	-
	A 831 93 A	01 D- EXT	-

.../...

15/02/91  
 1117 07-7460-10  
 PAGE : 2  
 C07 ↑

**ELEMENTS ARRIERE DE CAISSE**  
 HINTERE KAROSSERIETEILE  
 BODY REAR ELEMENTS  
 ELEMENTOS TRAS.  
 ELEMENTI POSTE

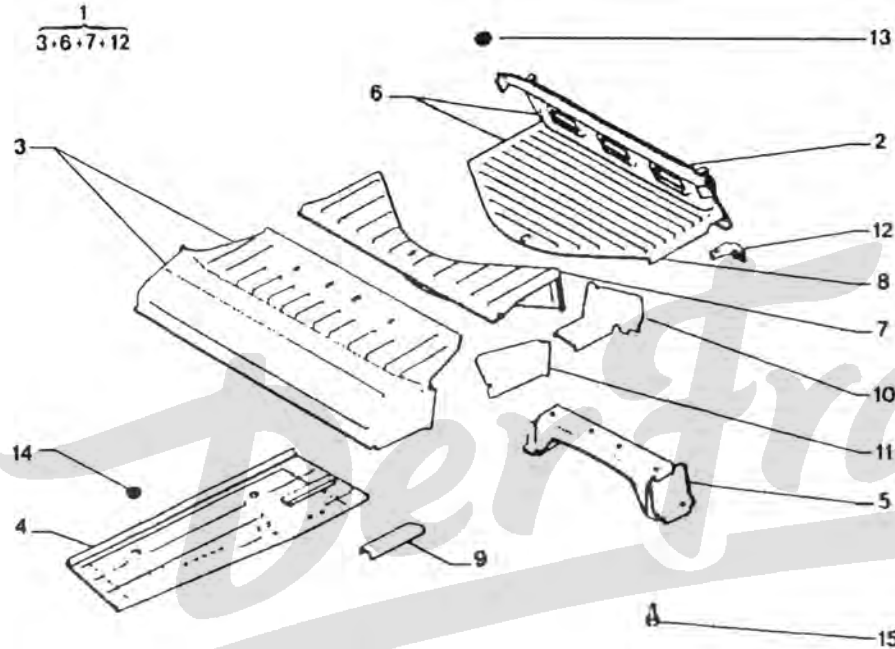

1114

7-742-10

Z7460100

13	79 03 074 050	02	DIAM 32	2550 ▶	OBTURATEUR STOPFEN PLUG OBTURADOR PANEL OTTURATURE
14	AY 831 102 A	04			-
15	23 828 019	04	TH 9X1,25-32 RMP 23853309		VIS SCHRAUBE PUMP FIX SCREW TORNILLO VITE POMPA HP

12	A 821 72	01	G- AR	TOLE FERMETURE ABSCHLUSSBLECH LOCKING PLATE CHAPA DE CIERRE LAMIERA CHIUSUR
	A 821 72 A	01	D- AR	-
13	5 412 367	02	DIAM 30	▶ 2549 OBTURATEUR STOPFEN PLUG OBTURADOR PANEL OTTURATURE

**PORTES LATERALES**  
 VORDERE TUEREN - RECHT  
 FRONT DOORRS - RIDHT  
 PUERTA LATERALE - DERECHA  
 PORTIERA LATERALE - DESTRO

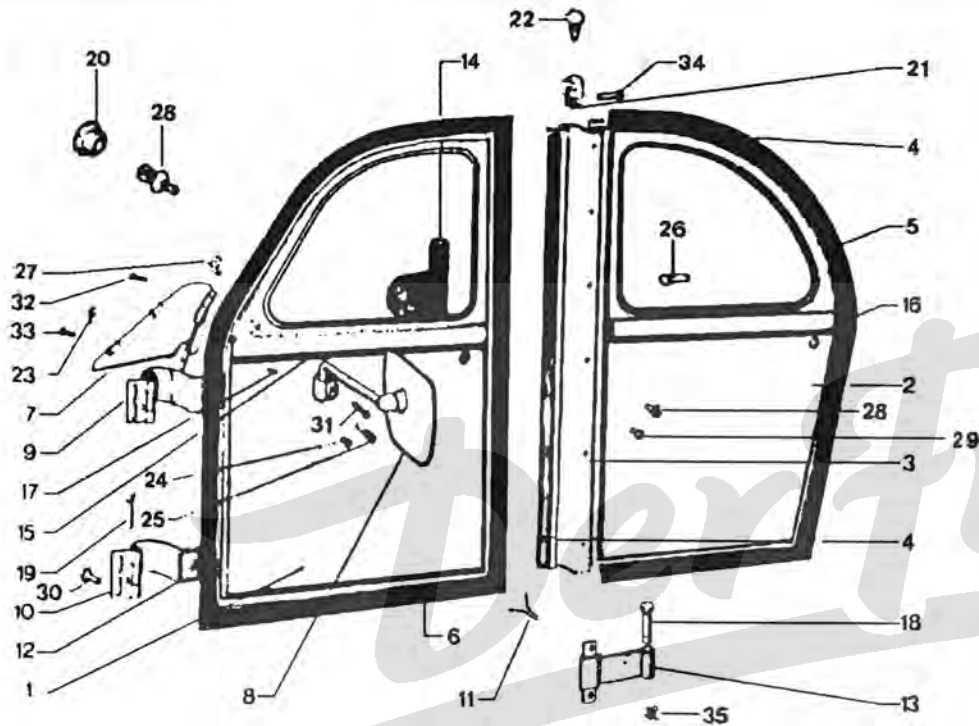

1117  
 [6/89] 07 8410.10  
 Z8410100

01	5 462 716	01 G-	PORTE AV VORDERTUER FRONT DOOR PUERTA AV PORTA ANTER.
	5 462 717	01 D-	-
02	5 454 450	01 G-	PORTE AR HINTERTUER REAR DOOR PUERTA AR PORTA POSTER.

02	5 454 451	01 D-	PORTE AR HINTERTUER REAR DOOR PUERTA AR PORTA POSTER.
03	5 413 823*700	02 AR	PROTECTEUR TUERABSCHIRMUNG DOOR PROTECTOR PROTECTOR PROTEZIONE
04	5 413 824 XA	02 AR	PROFILE ABSCHLUSSPROFIL FINISHER PANEL PERFIL PROFILO FINITUR
	5 413 825	02 AR - LON815	-
05	A 842 88 B	01 G- AR CAOUTCHOUC	-
	A 842 88 C	01 D- CC - AR CAOUTCHOUC	-
06	AZU 841 81	01 G- AV	-
	95 624 168	01 D- AV RMP AZU84181A	-
07	95 561 118	01 G- AV RMP 5401156	PROTECTEUR SCHUTZ DOOR PROTECTOR PROTECTOR PROTEZIONE
	95 561 119	01 D- AV RMP 5401157	-
08	95 495 801	01 G- RMP 5424744	2061 ► RETROVISEUR EXT AUSSEN.R.SPIEGEL EXT VIEW MIRROR RETROVISOR EXT RETROVISORE EXT
	95 495 803	01 D- RMP 5424751	2061 ► -
09	5 450 124 VA	01 G- SUP RMP5450124200	CHARNIERE PORTE SCHARNIER DOOR HINGE BISAGRA CERNIERA
	5 450 125 VA	01 D- SUP RMP5450125200	-

15/02/91  
 1117 07-8410-10  
 PAGE : 2  
 C09 ↑

**PORTES LATERALES**  
 VORDERE TUEREN - RECHT  
 FRONT DOORRS - RIDHT  
 PUERTA LATERALE - DERECHA  
 PORTIERA LATERALE - DESTRO

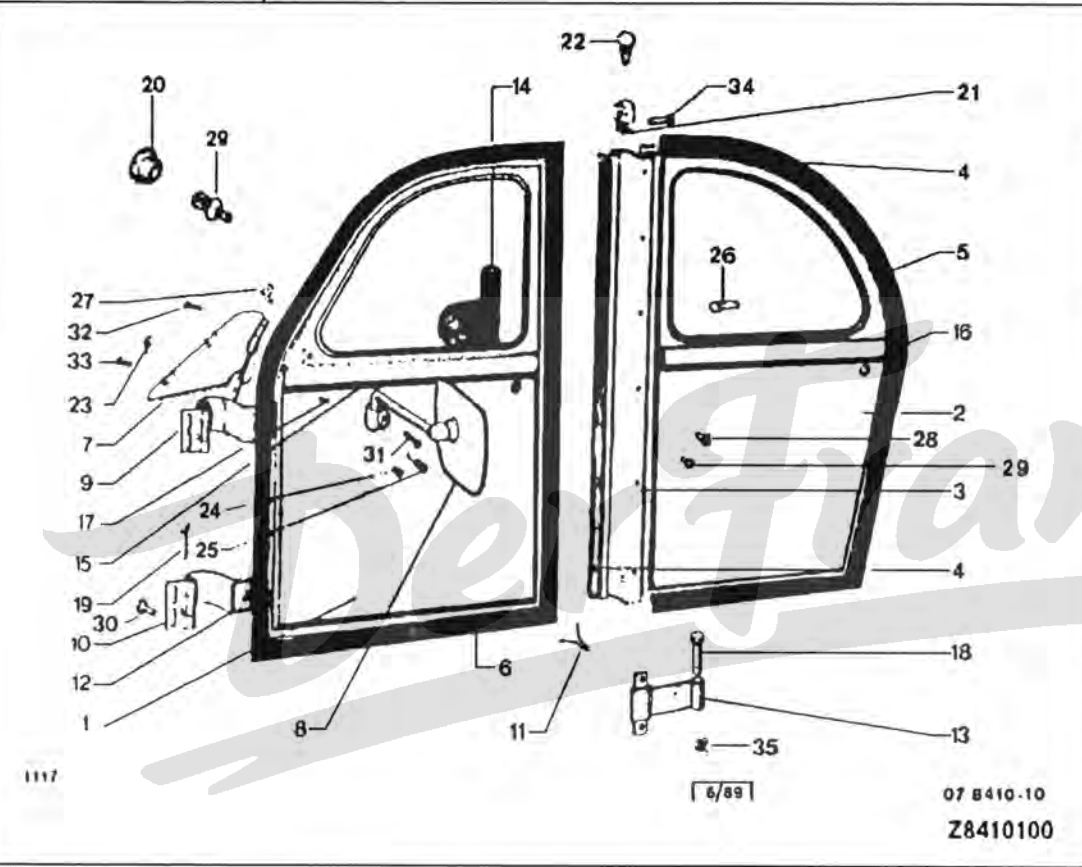

1117

[6/89]

07 8410-10  
 Z8410100

10	5 450 129 VA	01	G- INF RMP5450129200	CHARNIERE PORTE SCHARNIER DOOR HINGE BISAGRA CERNIERA
	5 450 130 VA	01	D- INF RMP5450130200	-
11	AZ 841 53	02		PATTE HALTELASCHE SUPPORT LUG SOPORTE STAFFA

12	AZ 841 60	04	70X22-	CALE DE REGLAGE EINSTELLBEILAGE ADJUSTMENT SHIM CALA REGLAJE SPESSORE REGOL.
13	A 841 78	02		TIRANT DE PORTE TUERSTREBE DOOR ARRESTER TIRAHE PUERTA TIRANTE FERMO
14	AZ 841 110 A	02		RENFORT VERSTAZRKUNG REINFORCEMENT REFUERZO RINFORZO
15	AZ 854 11	02	AV-LON 750	BAGUETTE ZIERLEISTE STRIP MOLDURA PROFILO
16	A 854 12	02	AR - LON 660	-
17	A 854 20	14		AGRAFE KLAMMER CLIP GRAPA AGRAFE
18	5 437 263	02	6X22	AXE DE TIRANT BOLZEN F.STREBE STRUT PIN EJE TIRANTE PERNO TIRANTE
19	AZ 841 108 A	04		AXE CHARNIERE BOLZEN HINGE SHAFT EJE BISAGRA PERNO
20	5 424 915*700	02	EXT	OBTURATEUR STOPFEN CONTROL PLUG OBTURADOR OTTUROTARO
21	AZ 821 76	02	SUP ▶ 04/80	PATTE FIX BUTEE LASCHE FIXING BRACKET SOPORTE FIX STAFFA

.../...

15/02/91  
 1117 07-8410-10  
 PAGE : 3  
 C10 ↑

**PORTES LATERALES**  
 VORDERE TUEREN - RECHT  
 FRONT DOORRS - RIDHT  
 PUERTA LATERALE - DERECHA  
 PORTIERA LATERALE - DESTRO

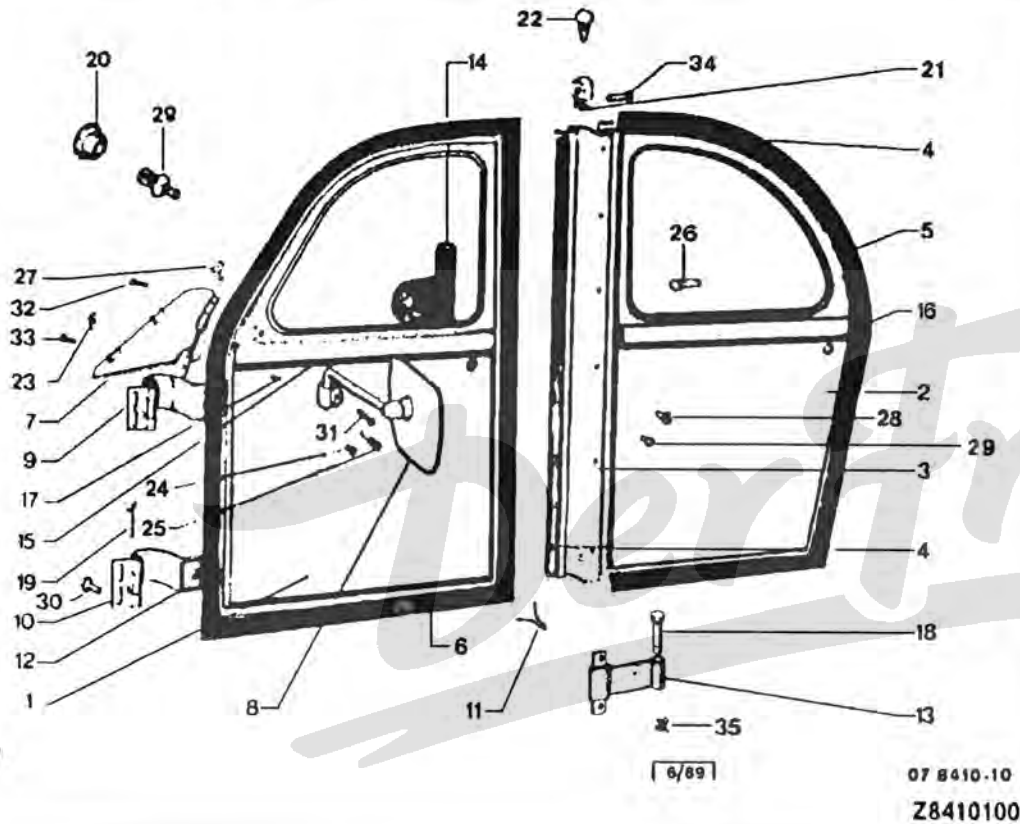

24	5 424 742	02	TCB 5X12	VIS DE REGLAGE SCHRAUBE ADJUSTMNT SCREW TORNILLO REGLAJ VITE
25	5 424 743	01	DIAM 10	-
26	A 842 94	02	INT-LAT-AR	POIGNEE TIRAGE ZUGGRIF PULL HANDLE TIRADOR VITE
27	ZC 9619 829 U	04		AGRAFE KLAMMER CLIP GRAPA AGRAFE
28	ZC 9615 602 U	12	DIAM 4X0,75	RIVET NIET RIVET REMACHE RIVETTO
	ZC 9615 605 U	12	DIAM 4X0,70	-
	79 03 072 243	12	"PCP" DIAM32	-
29	26 130 639	12		-
30	79 03 101 771	16	DIAM7X100-20	VIS TH SCHRAUBE CAPSCREW TORNILLO TH VITE
31	79 03 007 147	02	DIAM 4X0,70 LON 8	VIS TCB SCHRAUBE CAPSCREW TORNILLO TCB VITE
32	79 03 016 198 RP 20964009	06	TFB 3 5X9,5	VIS TOLE TF BLECHSCHRAUBE TAPPING SCREW TORNILLO R CHAP VITE LAMIERA
33	79 03 007 094	02	4X0,70-16 ▶ 04/80	VIS TCB SCHRAUBE CAPSCREW TORNILLO TCB VITE

22	5 486 445	02	SUP	04/80 ▶	OBTURATEUR STOPFEN PLUG OBTURADOR OTTURATORE
23	AZ 841 121	04	30X12X1,5		PLAQUETTE ARRET ANHALTEPLAETTCH STOP PLATE PLAQUETA PIASTRA ARRESTO

.../...

15/02/91  
1117 07-8410-10  
PAGE : 4  
C11 ↑

**PORTES LATERALES**  
VORDERE TUEREN - RECHT  
FRONT DOORRS - RIDHT  
PUERTA LATERALE - DERECHA  
PORTIERA LATERALE - DESTRO

**XT**

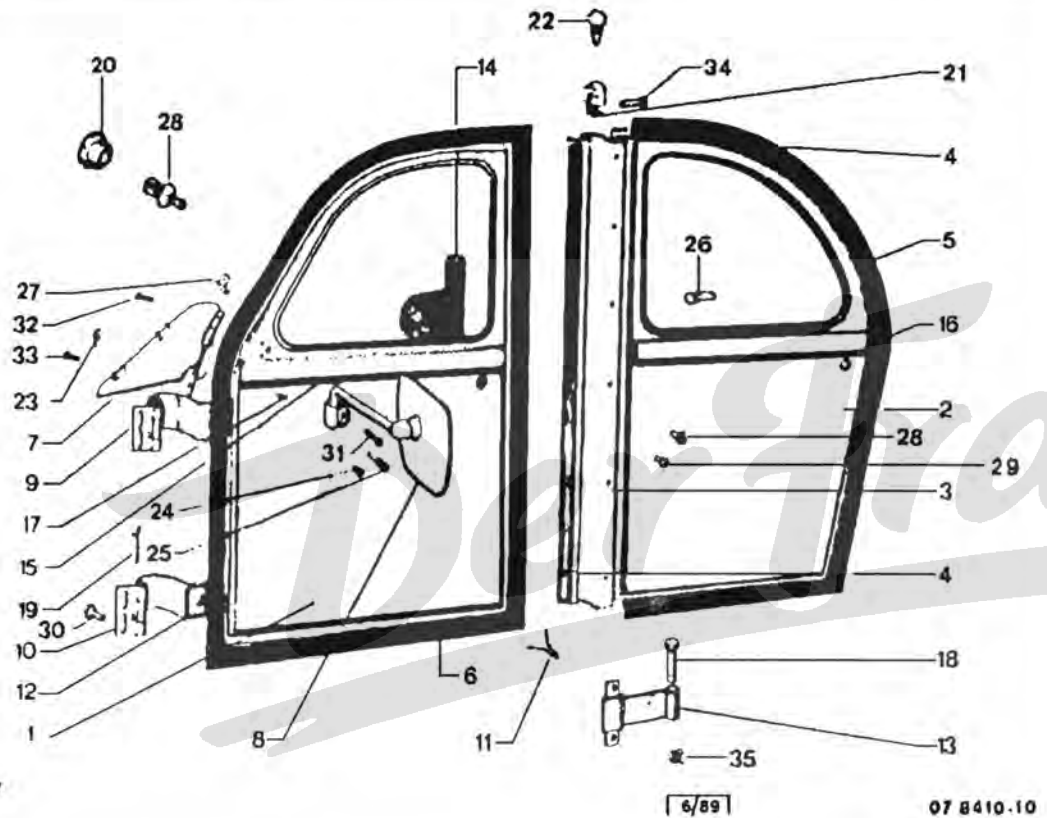

1117

[6/89]

07 8410.10  
Z8410100

57

95 561 039

02 INF-AV  
-(D)

PROTECTEUR  
SCHUTZ  
DOOR PROTECTOR  
PROTECTOR  
PROTEZIONE

58

95 561 040

02 SUP-AV  
-(D)

-

77

95 495 802

01 D-  
-CAD  
RMP 5430240

2061 ▶

RETROVISEUR EXT  
AUSSEN.R.SPIEGEL  
EXT VIEW MIRROR  
RETROVISOR EXT  
RETROVISORE EXT

85

5 501 036

99 -(D)

AGRAFE  
KLAMMER  
CLIP  
GRAPA  
AGRAFE

95 561 037

02 -(D)

EMBOUT  
ENDSTUECK  
SOCKET TOOL  
TERMINAL  
TERMINALE

34

79 03 008 142

04 5X12

VIS TRL  
SCHRAUBE  
CAPSCREW  
TORNILLO R L  
VITE

35

79 03 037 006

04 HE 5X0,80

ECROU A EMBASE  
MUTTER  
NUT WITH BASE  
TUERCA CON BASE  
DADO A BASETTA

02/91  
17 07-8450-10  
GE : 1  
2 ↑

**PORTE DE COFFRE**  
HECKKLAPPE  
BOOT DOOR  
PUERTA DE MALETA  
PORTELLO COFANO BAULE

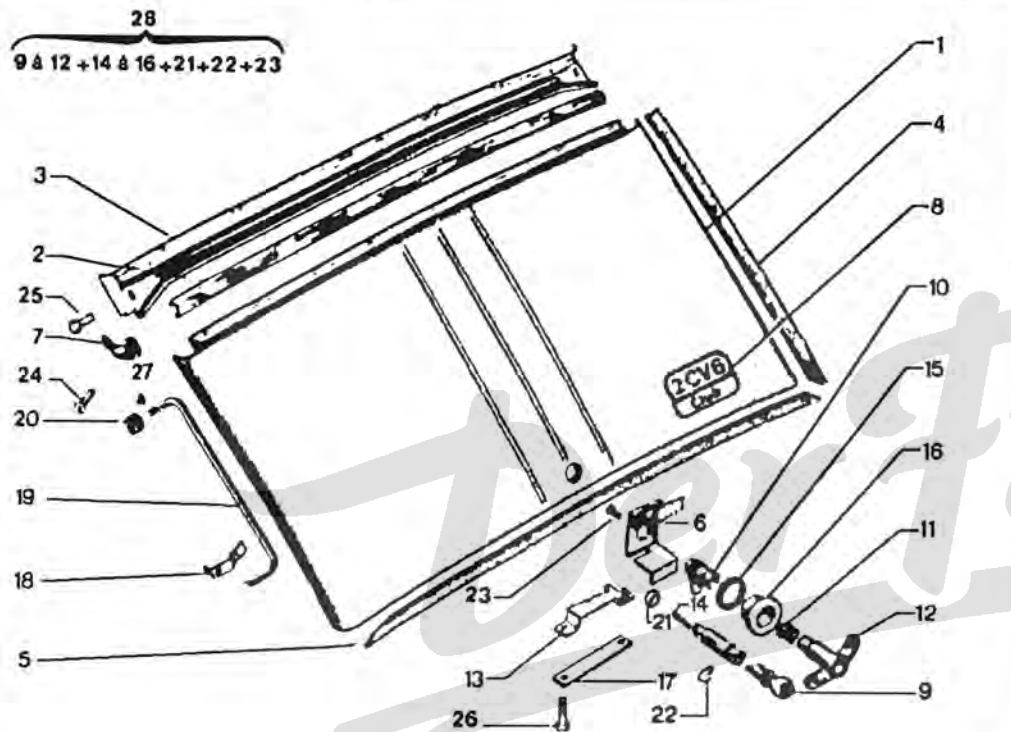

7.844.10  
Z8450100

96 995 278

01 RMP AZ844219A

PORTE AR  
HINTERTUER  
REAR DOOR  
PUERTA AR  
PORTA POSTER.

95 578 708

01 RMP 5441332

2061 ►  
CHARNIERE PORTE  
SCHARNIER  
DOOR HINGE  
BISAGRA  
CERNIERA

03	AZ 844 24 A	01 SUP		TRVERSE TRVERSE CROSSPIECE TRAVIESA TRAVERSA
	95 592 908	01 SUP- << LEVMAL >>		-
04	AZ 844 72 RP AZ84489	01 G- LAT-LON 515 CAOUTCHOUC		JOINT VOLET AR HECKKLAPPDICHT. WEATHERSTRIP JUNTA DE PUERTA GUARNIZIONE
	AZ 844 72 A RP AZ84489	01 D- LAT-LON 515 CAOUTCHOUC		-
05	AZ 844 89	01 INF-LON 940 CAOUTCHOUC		-
06	AZ 844 123	01		PONTET STEG HITCH BRACKET PROTECTOR SUPPORTO
07	95 600 318	01 G- RMP:AZ844128	2245 ►	EMBOUT ENDSTUECK SOCKET TOOL TERMINAL TERMINALE
	95 592 565	01 D- RMP AZ844128A	2445 ►	-
08	95 579 372	01 -2CV8 -CLUB RMP95539951	2061 ►	MONOGRAMME AR NAMENZUG HINTEN REAR NAME-PLATE MONOGRAMA AR MONOGRAMMA POST
	95 579 370	01 -2CV6 -SPECIALE	2061 ►	-
	95 579 371	01 "2CV6-SPECIALE E" 07/82	2396 ►	-
	95 579 369	01 "CITROEN"	2061 ►	-
09	5 410 765	01 ENS DE 3 RONIS RMP:5441233 2 POS "JOURNEE"		BARILLET VERROU EINSATZ LOCK BARREL BOMBILLO CERRAD BARILETTO

.../...

15/02/91  
1117 07-8450-10  
PAGE : 2  
C13 ↑

PORTE DE COFFRE  
HECKKLAPPE  
BOOT DOOR  
PUERTA DE MALETA  
PORTELLO COFANO BAULE

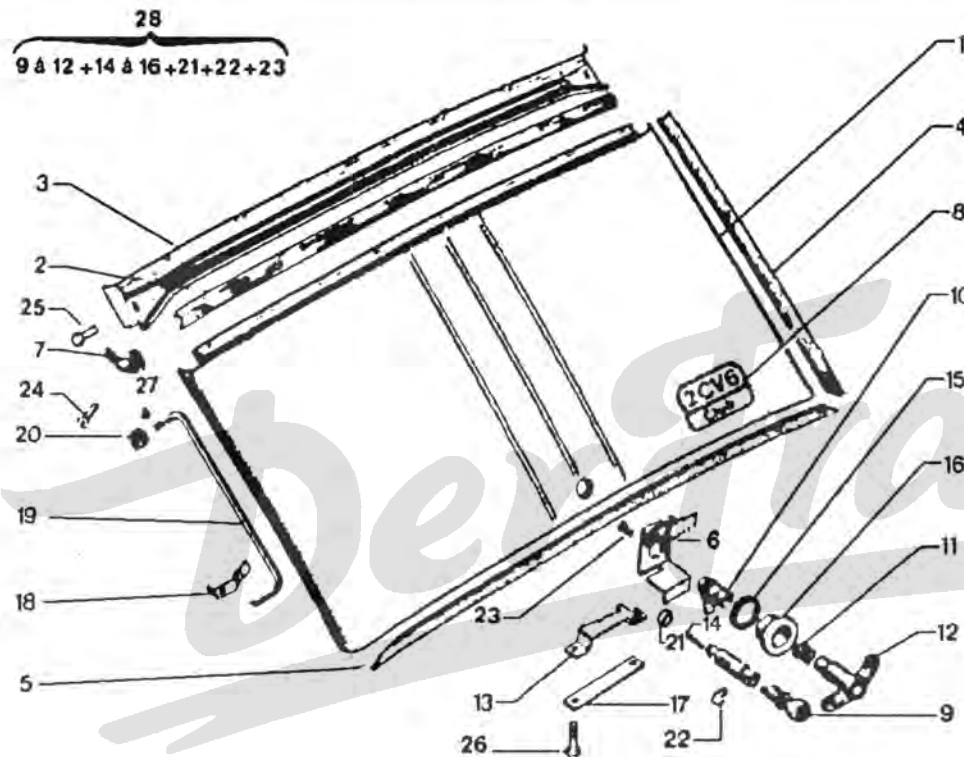

1114

7.844.10  
Z8450100

10	96 995 318	01	RMP AZ861322A	VERROU BARILLET EINSATZSPERRST. CYLINDER BLOCK POMBILLO ARRESTABARILET.	19	AZ 844 64	01		BEQUILLE STUETZE TAILGATE PROP VARILLA ASTA SOSTEGNO
11	AZ 861 34	01		RESSORT FEDER LOCKING SPRING MUELLE MOLLA	20	5 419 946	01	6X16X12,5 CAOUTCHOUC	BAGUE DE LEVIER HUELSE AN HEBEL LEVER RING CASQUILLO BOCCOLA LEVA

12	5 468 191	01		POIGNEE GRIFF DOOR HANDLE EMPUNADURA MANIGLIA
13	AY 861 57	01	ENT 73	GACHE SERRURE SCHLOSSFALLE LOCK STRIKER ARMELLA STAFFA SERRATUR
14	5 478 655	01		BROCHE SPINDELSTIFT PIN CONECTOR MANDRINO
15	A 861 74	01	29X40X4	RONDELLE ETC DICHTSCHEIBE SEAL WASHER ARANDELA RONDELLA
16	AZ 861 89	01	11,5X44X18	EMBASE BODENSTUECK HANDLE BASE BASE AGARRADERO BASETTA
17	AY 861 393 A RP AY86190	01		PLAQUETTE GEWINDEPLAKETTE TAPPED PLATE PLAQUETA PLACCHETTA
18	AZ 844 59	01		RESSORT HALTEFEDER RETAIN SPRING MUELLE SUJECION MOLLA SOSTENO
19	AZ 844 64	01		BEQUILLE STUETZE TAILGATE PROP VARILLA ASTA SOSTEGNO
20	5 419 946	01	6X16X12,5 CAOUTCHOUC	BAGUE DE LEVIER HUELSE AN HEBEL LEVER RING CASQUILLO BOCCOLA LEVA

.../...



15/02/91  
 1117 07-8450-10  
 PAGE : 3  
 C14 ↑

**PORTE DE COFFRE**  
 HECKKLAPPE  
 BOOT DOOR  
 PUERTA DE MALETA  
 PORTELLO COFANO BAULE

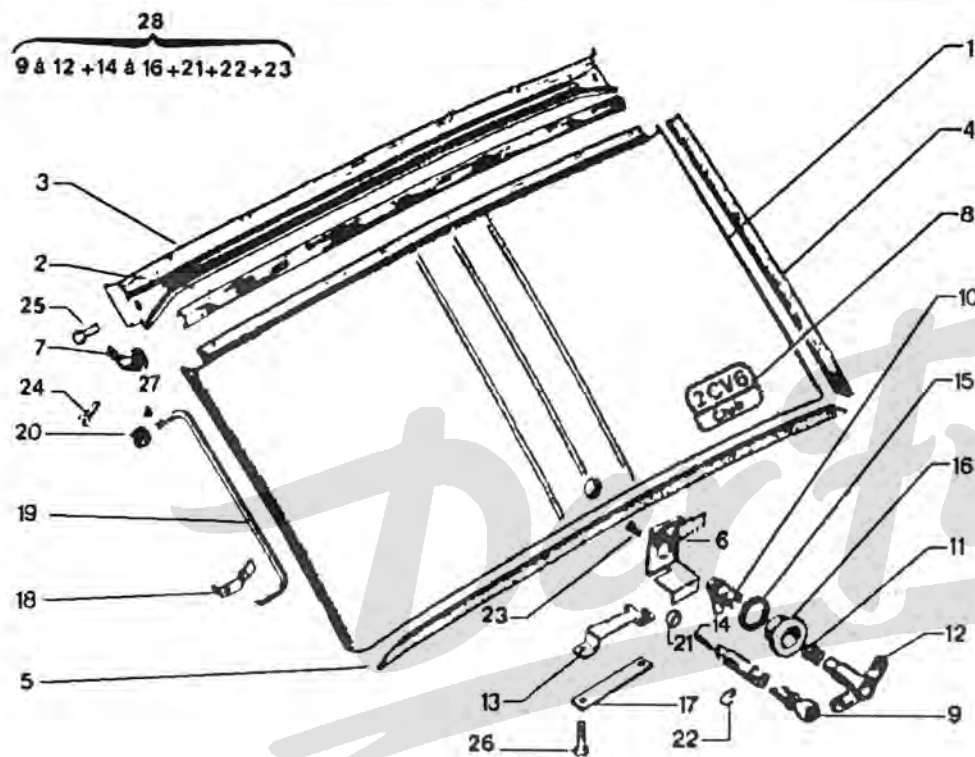

1114

7.844.10  
 Z8450100

23	79 03 005 038 RP 24708009	01	5X0,80-16	VIS TFB METALISCHRAUBE METAL SCREW TORNILLO METAL VITE
24	ZD 9222 400 Z	04	4X0,70X10	VIS TF SCHRAUBE CAPSCREW TORNILLO VITE
	79 03 004 037	04	DIAM 4X0,70 - 10	-
25	79 03 201 129	02	DIAM 5X0,80-12 RMP 700J101248	VIS TH SCHRAUBE CAPSCREW TORNILLO TH VITE
26	79 03 007 103	02	5X0,80-16 RMP 24533319	VIS TOLE TCB BLECHSCHRAUBE TAPPING SCREW TORNILLO CHAPA VITE
27	79 03 080 036	01	DIAM 6	RONDELLE GROWER GROWERSCHEIBE SPRING WASHER ARANDELA RONDELLA GROWER
28	95 584 060	01	"PAM"	ENS REPARATION REPARATURSATZ LOCK REPAIR SET CONJ. REPARAC. INS. RIPARAZIONE

21	AZ 8/61 124	01	3X8X2	RONDELLE SCHEIBE WASHER ARANDELA RONDELLA
22	75 519 741	01		CIRCLIP SICHERUNGSRING CIRCLIP ANILLO FERMAGLIO

15/02/91  
1117 07-8453-20  
PAGE : 1  
C15 →

**ARMATURE DE VOLET ARRIERE**  
**ARMATURF.HECKKLAPPE**  
**BOOT DOOR FRAME**  
**ARMADURA DEPUERTA DE MALETA**  
**ARMADURA POSTELLO BAULE**

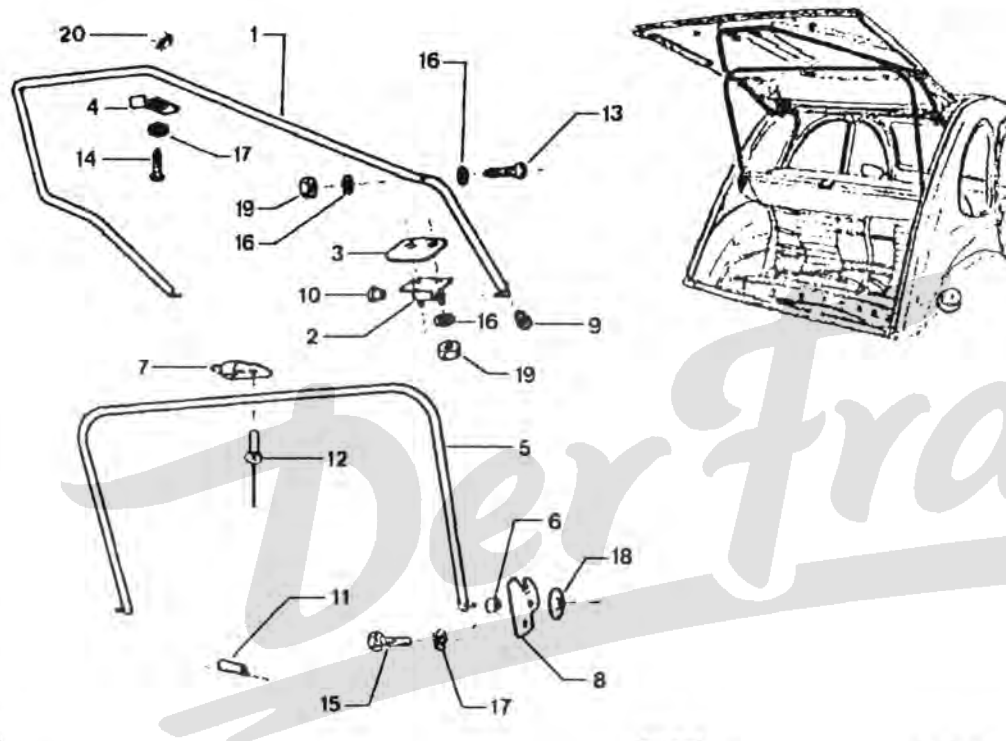

1114

[02/84]

7.844.20

28453200

01	95 592 560	01	ARTICULATION GELENK ARTICULATION ARTICULACION ARTICOLAZIONE	03	95 596 361	02	FEUTRE AIGUILLETEE PROTECTEUR SCHUTZ PROTECTOR PROTECTOR PROTEZIONE
02	95 592 903	01 G-	CHARNIERE VOLET SCHARNIER TAILGATE HINGE BISAGRA CERNIERA	04	95 592 907	02	PLAQUETTE GEWINDEPLAKETTE TAPPED PLATE PLAQUETA PLACCHETTA
	95 592 904	01 D-	-	05	95 592 567	01	BEQUILLE STUETZE TAILGATE PROP VARILLA ASTA SOSTEGNO
				06	95 592 911	02	DIAM 7X9-LON 10 ENTRETOISE ABSTANDSSTUECK SPACER JUEGO DISTANCIA DISTANZIALE
				07	95 592 909	01	PLAQUETTE GEWINDEPLAKETTE TAPPED PLATE PLAQUETA PLACCHETTA
				08	95 592 564	02 AR	SUPPORT HALTER BRACKET SOPORTE SUPPORTO
				09	95 595 884	02	EMBOUIT ENDSTUECK SOCKET TOOL TERMINAL TERMINALE
				10	79 03 074 015	02	DIAM 7 OBTURATEUR STOPFEN PLUG OBTURADOR OTTURATORE
				11	95 601 238	03	LON 40 CALE ANTI-BRUIT SCHEIBE G-DAEMP SHIM CALA ANTIRRUIDO SPESSORE ANTIRU

.../...

15/02/91  
 1117 07-8453-20  
 PAGE : 2  
 D15 ↓

**ARMATURE DE VOLET ARRIERE**  
 ARMATURF.HECKKLAPPE  
 BOOT DOOR FRAME  
 ARMADURA DEPUERTA DE MALETA  
 ARMADURA POSTELLO BAULE

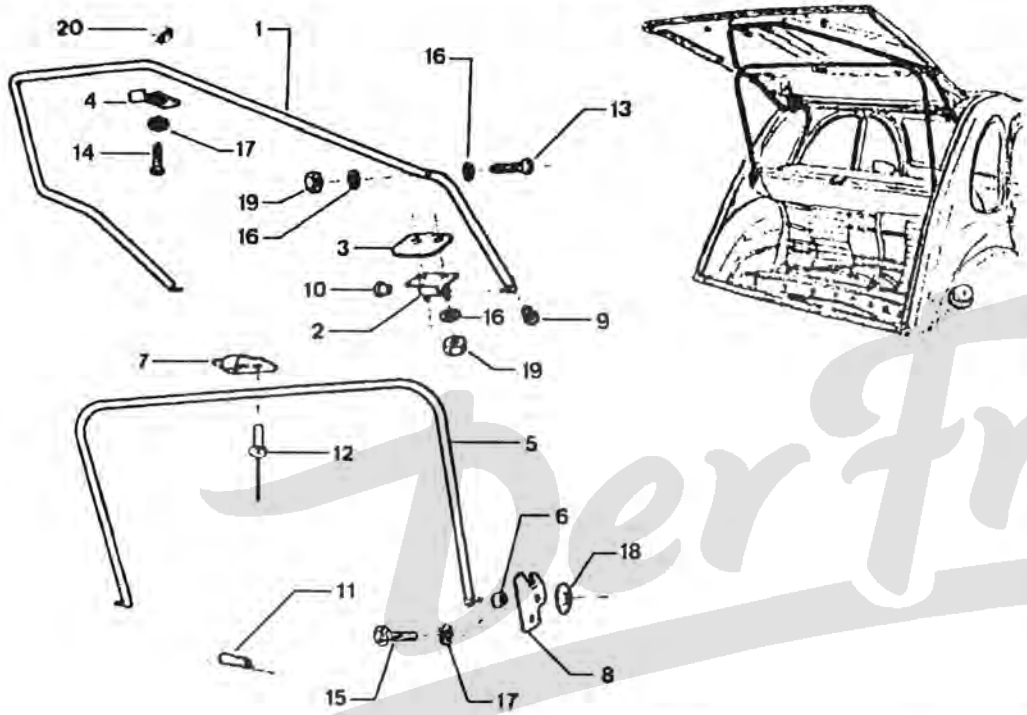

1114

02/84

\*.844.20

Z8453200

15	79 03 201 129	02	DIAM 5X0,80-12 RMP 7903101248	VIS TH SCHRAUBE CAPSCREW TORNILLO TH VITE
16	79 03 058 027	04	DIAM 5X12X1,2	RONDELLE A DENT ZAHNSCHEIBE SPRING WASHER ARANDELA RONDELLA DENTAT
17	79 03 058 038 NFP	04	ELAS DIAM - 5X16	-
18	79 03 080 036	02	DIAM 6	RONDELLE GROWER GROWERSCHEIBE SPRING WASHER ARANDELA RONDELLA GROWER
19	79 03 032 006	06	DIAM 5X0,80	ECROU MUTTER NUT TUERCA DADO
20	26 157 969 RP 7903081073	02	DIAM 4,85	CLIP MAINTIEN HALTECLIPS RETAINING CLIP PERFIL FIJACION GRAFFETTA

12	79 03 072 243	02	*POP* DIAM32	RIVET NIET RIVET REMACHE RIVETTO
	79 03 072 267	99	DIAM 3,2	-
13	79 03 007 072	02	5X0,80-25	VIS TCB SCHRAUBE CAPSCREW TORNILLO TCB VITE

15/02/91  
1117 07-8501-10  
PAGE : 1  
D14 ↓

**CAPOT**  
MOTORHAUBE  
BONNET  
CAPO  
COFANO MOTORE

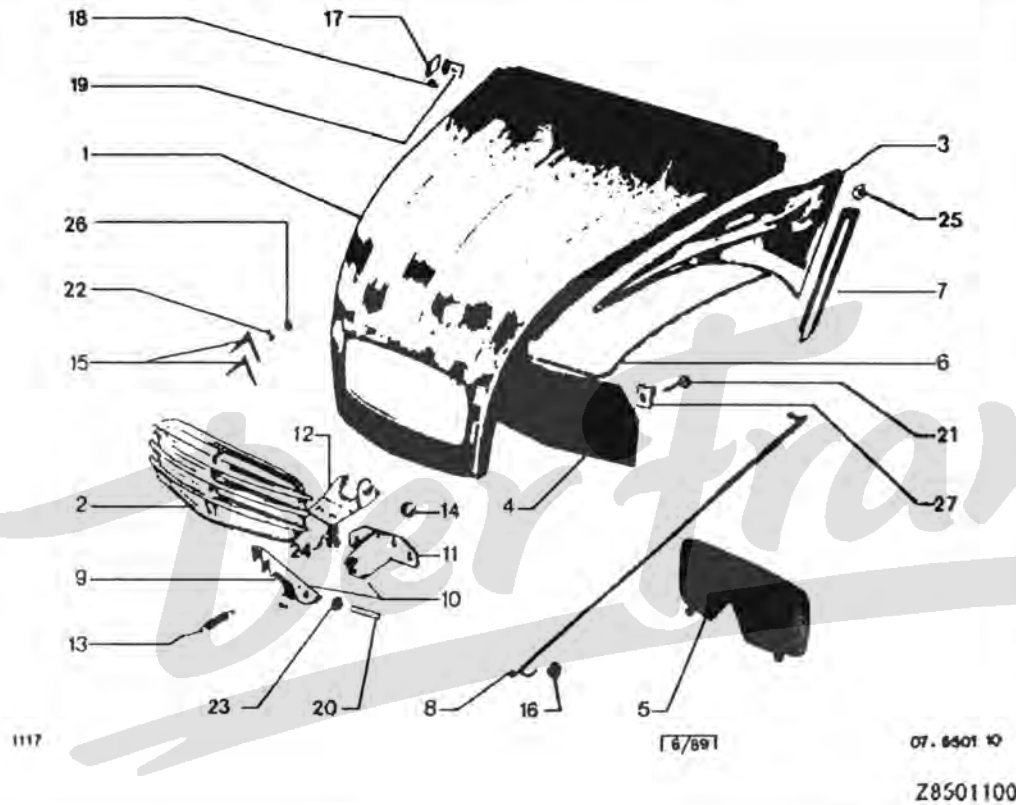

01 5 452 347

01

**CAPOT MOTEUR**  
HAUBE  
ENGINE BONNET  
CAPO MOTOR  
COFANO

02 5 452 350

01 RMP 5506543-95561467-5509087

**CALANDRE**  
KUEHLERGITTER  
RADIATOR GRILLE  
CALANDRA  
CALANDRA

03	AZ 852 62	01	G-	JOUE D'AILE AV KOTFL WANGE VOR WHEEL HOUSING FORRO ALETA AV LAMIERA PAR.ANT
	AZ 852 62 A	01	D-	-
04	AZ 852 5 A	01		<b>GRILLE CALANDRE</b> GRILL RADIATOR GRILLE REJILLA GRIGLIA
05	5 452 353	01	"601"	<b>RIDEAU PROTECT.</b> ABSCHIRMVORHANG PROTECTN SCREEN CORTINA PROTECC MASCHERINA PROT
06	5 480 221	01		<b>INSONO CAPOT</b> GERAEUSCHDAEMM SOUND PROOFING INSONORIZANTE INSONORIZAZION
07	AZ 852 151	02	LON 300	<b>CALE ANTI-BRUIT</b> SCHEIBE G-DAEMP SHIM CALA ANTIRRUIDO SPESSORE ANTI RU
08	75 511 478	01		<b>BEQUILLE CAPOT</b> STUETZE BONNET PROP VARILLA ASTA SOSTEGNO
	AZ 852 211 A	01	"ENAC"	-
09	AK 861 33	01		<b>CROCHEY</b> HAKEN HOOD HOOK GANCHO SEGURID. GANCIO
10	AK 861 37 B	01		<b>SERRURE CAPOT</b> HAUBENVERSCHLUS BONNET LOCK CERRADURA CAPO SERRATURA
11	AK 861 70	01		<b>SUPPORT CDE</b> ENTRIEGELHATER HOOD BRACKET SOPORTE MANDO SUPPORTO CDO

.../...

10/02/91  
 17 07-8501-10  
 AGE : 2  
 13 ↓

**CAPOT**  
 MOTORHAUBE  
 BONNET  
 CAPO  
 COFANO MOTORE

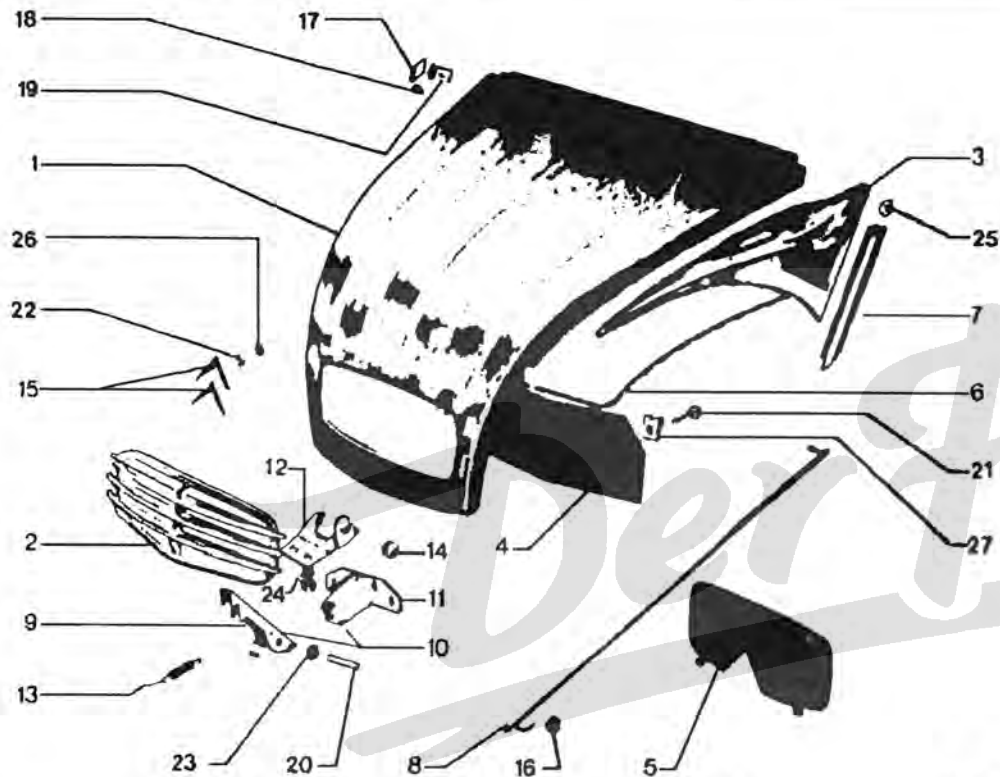

16/891

07. 8501 10

Z8501100

95 580 258

01

RMF AK861127

2214 ▶

**GACHE DE CAPOT**  
 EINRASTUNG  
 BONNET STRIKER  
 ARMELLA  
 STAFFA

5 420 639

01

**RESSORT**  
 RUCKZUGFEDER  
 RETURN SPRING  
 MUELLE  
 MOLLA RICHIAMO

14

5 427 281

01 CAOUTCHOUC ▶ 2215

**GACHE DE CAPOT**  
 EINRASTUNG  
 BONNET STRIKER  
 ARMELLA  
 STAFFA

15

5 431 122

02

**CHEVRONS**  
 CITROEN-ZEICHEN  
 EMBLEM STRIPE  
 CHEVRONS  
 EMBLEMA SCAGL

16

5 419 946

01 6X16X12,5  
 CAOUTCHOUC

**BAGUE DE LEVIER**  
 HUELSE AN HEBEL  
 LEVER RING  
 CASQUILLO  
 BOCCOLA LEVA

17

AZ 852 79

04 LON 16

**OEILLET**  
 GUMMIOESE  
 RUBBER GROMMET  
 PASACABLE  
 OCCHIELLO

18

95 632 552

04

**BUTEE CAOUTCHOU**  
 ANSCHLAG  
 RUBBER BUFFER  
 TOPE GOMA  
 REGGISPINTA

19

AZ 852 80 A

04

**PATTE**  
 HALTELASCHE  
 SUPPORT LUG  
 SOPORTE  
 STAFFA

20

ZC 9618 713 U

01 DIAM 6X28

**AXE**  
 BOLZEN  
 BONNET PIN  
 EJE  
 PERNO

21

79 03 016 189  
 RP 7903016283

02 DIAM 4,8X13

**VIS TOLE TCB**  
 ELECHSCHRAUBE  
 TAPPING SCREW  
 TORNILLO CHAPA  
 VITE

22

5 413 142

04 CAOUTCHOUC

**RONDELLE CAOUT.**  
 GUMMISCHEIBE  
 RUBBER WASHER  
 ARANDELA GOMA  
 RONDELLA

.../...

15/02/91  
1117 07-8501-10  
PAGE : 3  
D12 ↓

**CAPOT**  
MOTORHAUBE  
BONNET  
CAPO  
COFANO MOTORE

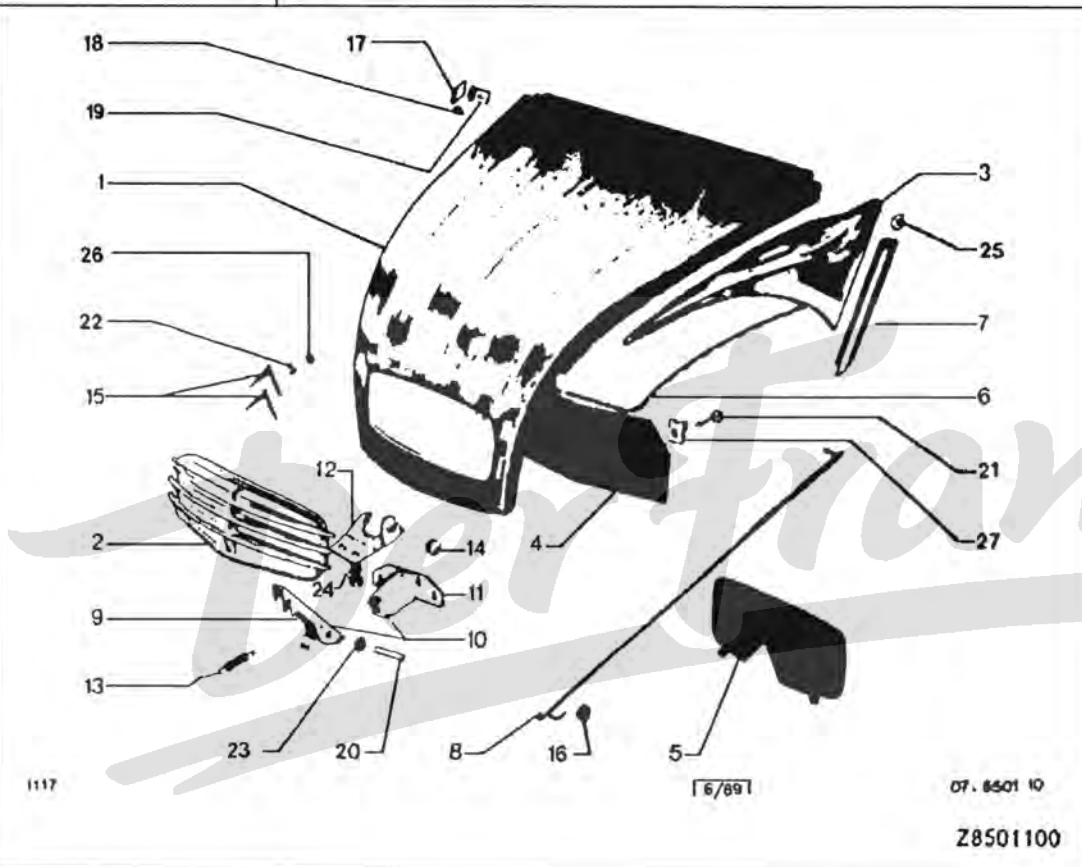

1117

16/891

07. 8501 10

Z8501100

26	26 240 089 RP 95499019	04	CLIP MAINTIEN HALTECLIPS RETAINING CLIP PERFIL FIJACION GRAFFETTA
27	26 157 619 RP 7903046044	02	CLIP ECROU CARRE OUADR.MUTTER SQUARE NUT TUERCA CUADRADA DADO QUADRATO
80	5 489 177 RP 5480224	01	AV -(S) <b>XT</b> INSONO CAPOT GERAEUSCHDAEMM SOUND PROOFING INSONORIZANTE INSONORIZAZION
23	79 03 056 005	06	DIAM 5,3X9,4 RONDELLE A DENT ZAHNSCHEIBE SPRING WASHER ARANDELA RONDELLA DENTAT
24	79 03 058 038 NFP	04	ELAS DIAM - 5X16 -
25	79 03 053 372	02	DIAM 5X16 RONDELLE PLATE FLACHSCHEIBE PLAIN WASHER ARANDELA PLANA RONDELLA PIATTA

**AILES AVANT**  
 VORDERE KOTLUEGEL  
 FRONT WINGS  
 ALETAS DELANTERAS  
 PARAFANGHI ANT.

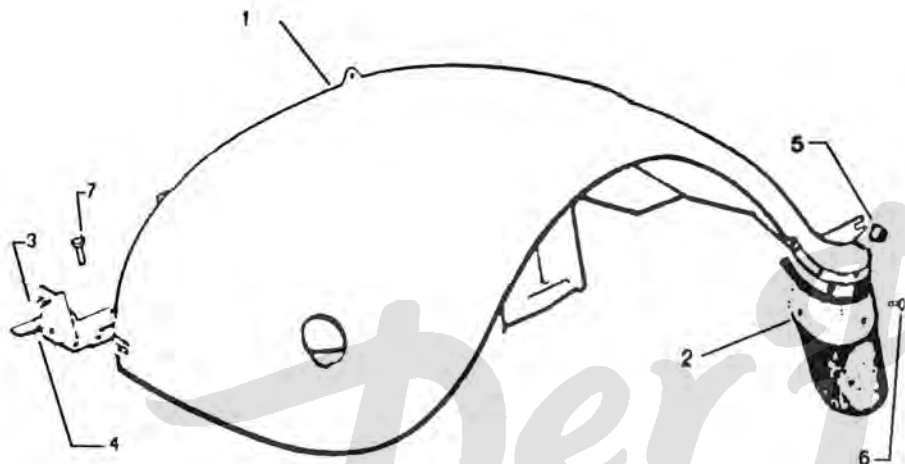

1114

7.831.10

Z8510100

03	A 851 86	08	TC 12X15	VIS CREUSE HOHLSCHRAUBE SCREW, SOCKET TORNILLO HUECO VITE
04	5 411 362	01	G- AV	SUPPORT HALTER PROTECT. BRACKET SOPORTE SUPPORTO
	5 411 363	01	D- AV	-
	5 411 500	01	G- AV -ATMOSPHERE POUSSIERS	-
	5 411 501	01	D- AV -ATMOSPHERE POUSSIERS	-
05	A 851 85 A	08	HE 12X1,75	ECROU MUTTER NUT TUERCA DADO
08	79 03 072 163	08	3,5X9 2856 ▶	RIVET NIET RIVET REMACHE RIVETTO
07	79 03 101 771	02	DIAM7X100-20 RMP 23719319	VIS TH SCHRAUBE CAPSCREW TORNILLO TH VITE
			<b>XT</b>	
58	95 577 429	01	G- -(CH) 2123 ▶	BAVETTES SCHMUTZFAENGER MUDFLAPS FALDILLA PARASPRUZZI
	95 577 428	01	D- -(CH) 2123 ▶	-

01	96 995 279	01	G- RMP AZ851301A	AILE AV KOTFLUEGEL VORN FRONT WING ALETA AV PARAFANGO ANT
	96 995 280	01	D- RMP AZ851302A	-
02	95 602 794	02	CAOUTCHOUC RMP AZ8514 - AZ8514A 2056 ▶	BAVETTES SCHMUTZFAENGER MUDFLAPS FALDILLA PARASPRUZZI

15/02/91  
 1117 07-8515-20  
 PAGE : 1  
 D10 ↓

**AILES ARRIERE**  
 HINTERE KOTFLUEGEL  
 REAR WINGS  
 ALESTA TRAS.  
 PARAFANGHI POST.

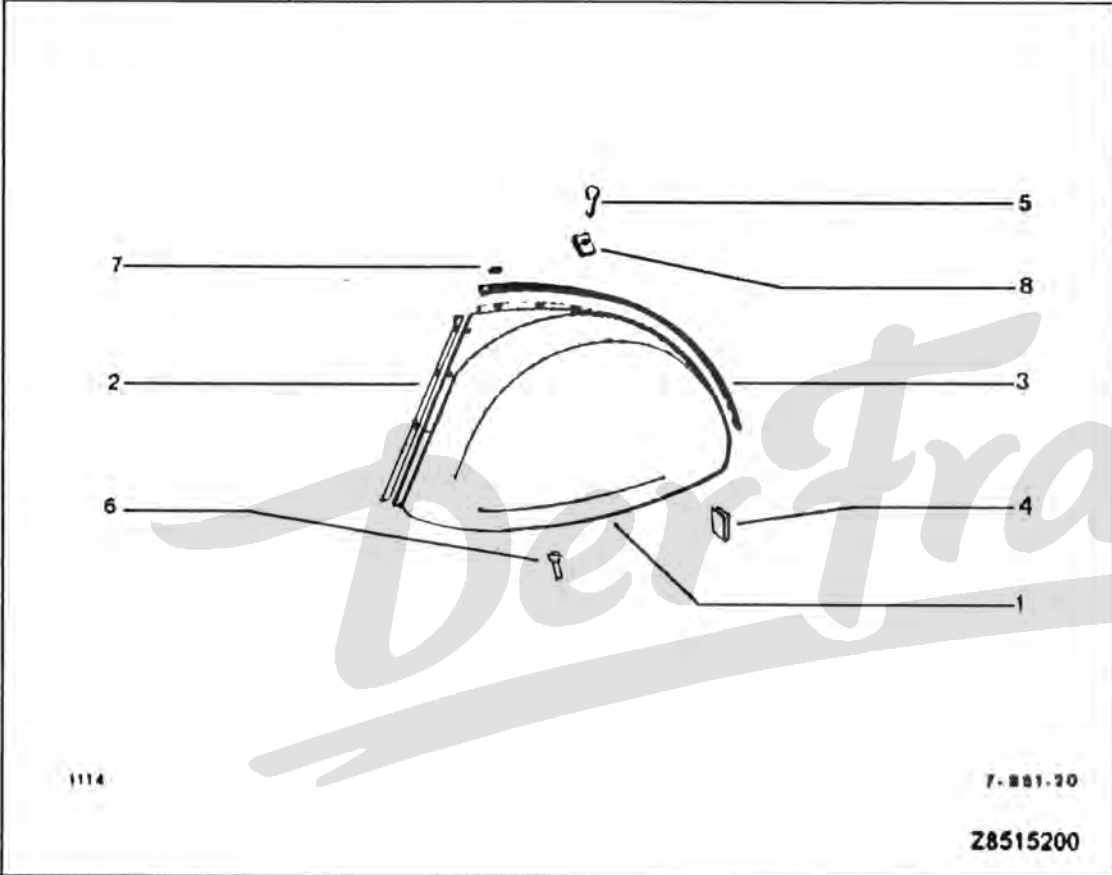

01	AZ 851 88 B	01 G-	AILE AR KOTFLUEGEL HINT REAR WING ALETA AR PARAFANGO POST
	AZ 851 88 C	01 D-	-
02	5 452 990	02 LON 590 RMP 5417357-5443880-5443881-	JONC NAHTSTUECK LINING PIPING JUNTA ACABADO CUCITURA

02	5 443 882 RP 5452990	02 LON 590-433*
03	A 851 87 A	02 LON 1090-SUP G-SUP D
04	ZC 9619 848 U	02
05	26 211 169	06 TH 1/4-LON 20 RMP ZC9621116Z
06	AZ 851 77	08 5X0,80-16 ▶ 2061
	79 03 201 130	08 DIAM 5 X 0,80 - 16 2061 ▶ RMP 7903024003
07	95 539 529 NFP	06 RMP 5420479
08	26 158 109	06 CLIP

JONC  
 NAHTSTUECK  
 LINING PIPING  
 JUNTA ACABADO  
 CUCITURA

-

AGRAFE  
 KLAMMER  
 CLIP  
 GRAPA  
 AGRAFE

VIS TH  
 SCHRAUBE  
 CAPSCREW  
 TORNILLO TH  
 VITE

VIS TCB  
 SCHRAUBE  
 CAPSCREW  
 TORNILLO TCB  
 VITE

VIS TH  
 SCHRAUBE  
 CAPSCREW  
 TORNILLO TH  
 VITE

RONDELLE ETC  
 DICHTSCHEIBE  
 SEAL WASHER  
 ARANDELA  
 RONDELLA

ECROU CARRE  
 QUADR.MUTTER  
 SQUARE NUT  
 TUERCA CUADRADA  
 DADO QUADRATO



**DECORS ADHESIFS**  
 KLEBEVERZIERUNG  
 ADHESIVE EMBELLISHMENT  
 EMBELLECIMIENTO ADHESIVO  
 ABBELLIMENTO ADESIVO

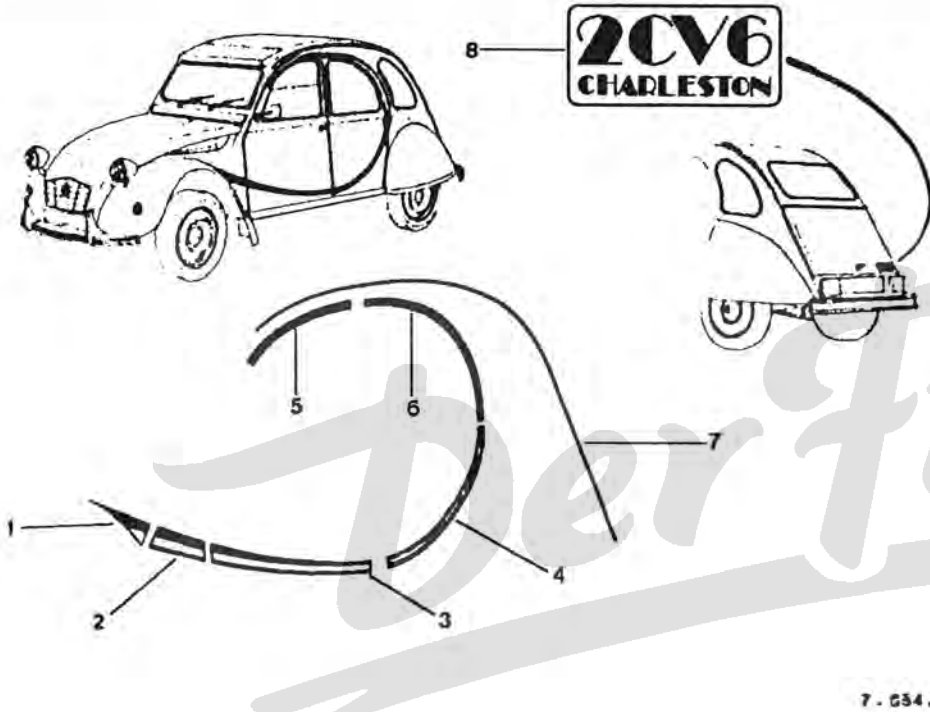

1114

7 - G34 - 10

Z8542100

**CHARLESTON**

1	95 561 451 KA	01 G-	DECOR ADHESIF KLEBEZIERSTREIF ADHESIVE TAPE DECORADO DECORAZ.ADESIVA
	95 561 452 KA	01 D-	-
	95 561 451 DA	01 G-	▶ 2304 -
	95 561 452 DA	01 D-	▶ 2304 -
	95 561 451 VP	01 G-	-

01	95 561 452 VP	01 D-	DECOR ADHESIF KLEBEZIERSTREIF ADHESIVE TAPE DECORADO DECORAZ.ADESIVA
02	95 631 715 KA	01 G- RMP 95561453KA	-
	95 631 716 KA	01 D- RMP 95561454KA	-
	95 561 453 DA	01 G-	▶ 2304 -
	95 561 454 DA	01 D-	▶ 2304 -
	95 631 715 VP	01 G- RMP 95561453VP	-
	95 631 716 VP	01 D- RMP 95561454VP	-
03	96 002 322 KA	01 G- AV RMP 95561455KA	3584 ▶ -
	96 002 323 KA	01 D- AV RMP 95561456KA	3584 ▶ -
	95 561 455 DA	01 G-AV	▶ 2304 -
	95 561 456 DA	01 D- AV	▶ 2304 -
	96 002 322 VP	01 G- AV	3584 ▶ -
	96 002 323 VP	01 D- AV RMP95561456VP	3584 ▶ -
04	96 002 324 KA	01 G- AR RMP 95561457KA	3584 ▶ -
	96 002 325 KA	01 D- AR RMP:95561458KA	3584 ▶ -
	95 561 457 DA	01 G- AR	▶ 2304 -
	95 561 458 DA	01 D-AR	▶ 2304 -
	96 002 324 VP	01 G- AR RMP 95561457VP	3584 ▶ -
	96 002 325 VP	01 D- AR RMP 95561458VP	3584 ▶ -
05	95 561 459 VA	01 G- AV	▶ 2792 -

15/02/91  
 1117 07-8542-10  
 PAGE : 2  
 D08 ↓

**DECORS ADHESIFS**  
 KLEBEVERZIERUNG  
 ADHESIVE EMBELLISHMENT  
 EMBELLECIMIENTO ADHESIVO  
 ABBELLIMENTO ADESIVO

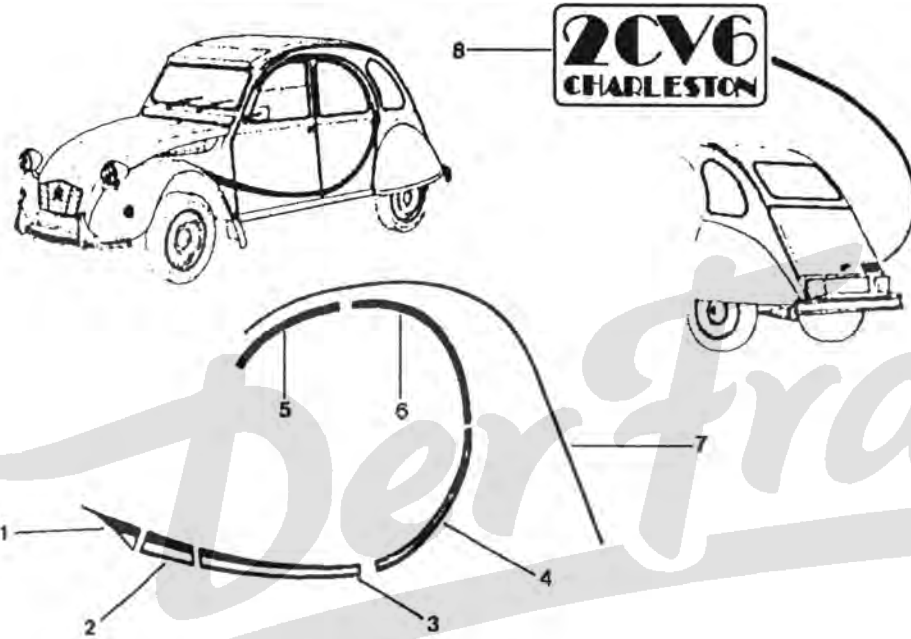

1114

7. 634.10

28542100

**CHARLESTON**

05	95 561 460 VA	01	D- AV	▶ 2792	DECOR ADHESIF KLEBEZIERSTREIF ADHESIVE TAPE DECORADO DECORAZ.ADESIVA
	95 561 459 VP	01	G- AV	▶ 2792	-
	95 561 460 VP	01	D- AV	▶ 2792	-
06	95 561 461 VA	01	G- AR	▶ 2792	-
	95 561 462 VA	01	D- AR	▶ 2792	-

06	95 561 461 VP	01	G- AR	▶ 2792	DECOR ADHESIF KLEBEZIERSTREIF ADHESIVE TAPE DECORADO DECORAZ.ADESIVA
	95 561 462 VP	01	D- AR	▶ 2792	-
07	95 561 463 VA	02		-	-
08	95 561 464 KA RP 95579373	01		▶ 2061	MONOGRAMME MONOGRAMM DOOR INSIGNIA MONOGRAMA MONOGRAMMA
	95 579 373	01		2062 ▶	-
				RMP 95561464DA	

15/02/91  
 1117 07-8542-20  
 PAGE : 1  
 D07 ↓

**DECORS ADHESIFS**  
 KLEBEVERZIERUNG  
 ADHESIVE EMBELLISHMENT  
 EMBELLECCIMENTO ADHESIVO  
 ABBELLIMENTO ADESIVO

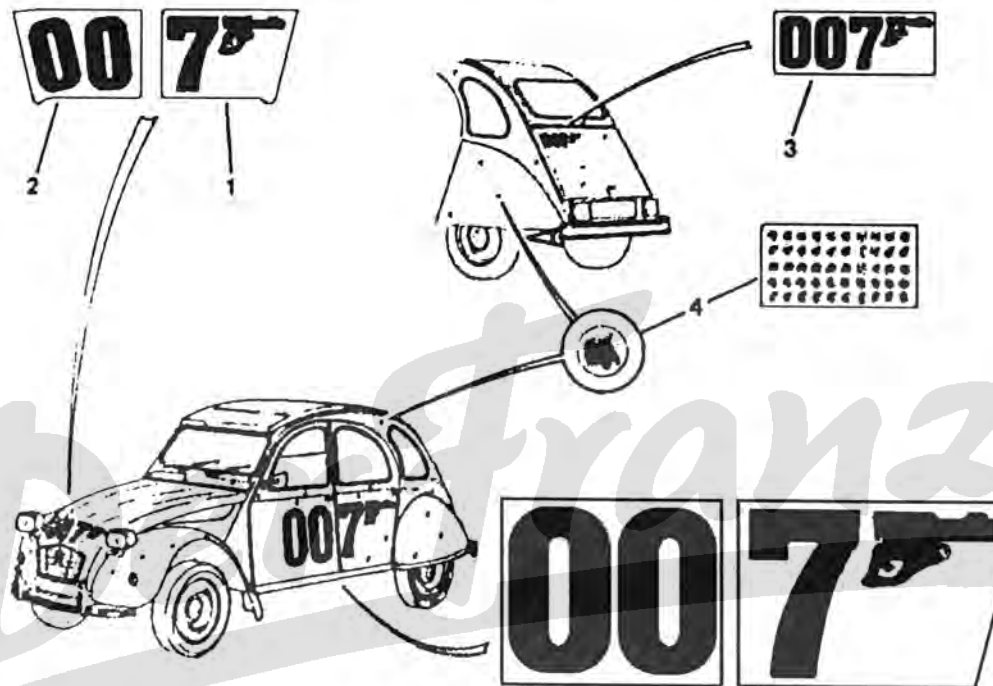

1117

[4/99]

07 8542.20

Z8542200

007

01	95 582 670 NFP	01	G-	DECOR ADHESIF KLEBEZIERSTUECK ADHESIVE STRIP DECORADO DECORAZ ADESIVA
02	95 582 671 NFP	01	D-	.
03	95 582 674 NFP	01		.
04	95 582 675	01		.

15/02/91  
 1117 07-8542-30  
 PAGE : 1  
 D06 ↓

**DECORS ADHESIFS**  
 KLEBEVERZIERUNG  
 ADHESIVE EMBELLISHMENT  
 EMBELLECIMIENTO ADHESIVO  
 ABBELLIMENTO ADESIVO

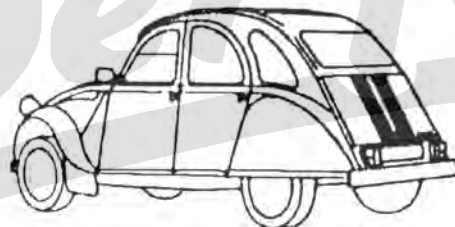
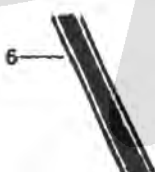

CITROËNA

1116

R57/851

7.854.30

Z8542300

**FRANCE 3**

01	95 593 842	01 G-	DECOR ADHESIF KLEBEZIERSTUECK ADHESIVE STRIP DECORADO DECORAZ ADESIVA
	95 593 843	01 D-	-
02	95 593 852	01 G-	-
	95 593 853	01 D-	-
03	95 593 848	01 G- AV	-

03	95 593 849	01 D- AV	DECOR ADHESIF KLEBEZIERSTUECK ADHESIVE STRIP DECORADO DECORAZ ADESIVA
04	95 593 846	01 G- AR	-
	95 593 847	01 D- AR	-
05	95 593 844	01 G- AR	-
	95 593 845	01 D- AR	-
06	95 593 841	02	-
07	95 593 840	01 D-	MONOGRAMME MONOGRAMM DOOR INSIGNIA MONOGRAMA MONOGRAMMA

15/02/91  
1117 07-8542-40  
PAGE : 1  
D05 ↓

**DECORS ADHESIFS**  
KLEBEVERZIERUNG  
ADHESIVE EMBELLISHMENT  
EMBELLECIMIENTO ADHESIVO  
ABBELLIMENTO ADESIVO

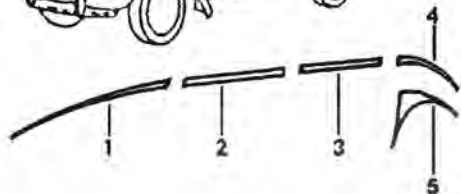

**DOLLY**

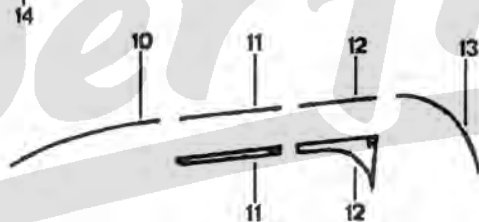

1115

[00'90]

2.854,40

28542400

**DOLLY**

- 1 POS: CARROSSERIE BLANCHE ET GRISE
- 2 POS: CARROSSERIE GRISE ET JAUNE
- 3 POS: CARROSSERIE GRISE ET ROUGE
- 4 POS: CARROSSERIE BLANCHE ET ROUGE
- 5 POS: CARROSSERIE JAUNE ET ROUGE
- 6 POS: CARROSSERIE BLANCHE ET VERTE
- 7 POS: CARROSSERIE BLEU NUIT ET JAUNE RIALTO

01	95 613 557	01 G- 1POS	DECOR ADHESIF KLEBEZIERSTUECK ADHESIVE STRIP DECORADO DECORAZ.ADESIVA
	95 613 556	01 D- 1POS	.

02	95 613 559	01 G- AV-1POS	DECOR ADHESIF KLEBEZIERSTUECK ADHESIVE STRIP DECORADO DECORAZ.ADESIVA
	95 613 558	01 D- AV-1POS	.
03	95 613 561	01 G- AR-1POS	.
04	95 613 565	01 G- AR-1POS	.
	95 613 564	01 D- AR-1POS	.
05	95 613 563	01 G- AR-1POS	.
	95 613 562	01 D- AR-1POS	.
06	95 613 575	01 G- 2POS	.
	95 613 574	01 D- 2POS	.
07	95 613 577	01 G- AV-2POS	.
	95 613 576	01 D- AV-2POS	.
08	95 613 579	01 G- AR-2POS	.
09	95 613 581	01 G- AR-2POS	.
	95 613 580	01 D- AR-2POS	.
10	95 613 567 EWT	01 G- 3POS	.
	95 613 566 EWT	01 D- 3POS	.
	95 613 567 EKB NFP	01 G- 4POS	.
	95 613 566 EKA NFP	01 D- 5POS	.
	95 613 567 ERJ NFP	01 G- 6POS	.
	95 613 566 ERJ NFP	01 D- 6POS	.
	95 613 567 EAA	01 G- 7POS	.
	95 613 566 EAA NFP	01 D- 7POS	.

.../...

15/02/91  
1117 07-8542-40  
PAGE : 2  
D04 ↓

**DECORS ADHESIFS**  
KLEBEVERZIERUNG  
ADHESIVE EMBELLISHMENT  
EMBELLECIMIENTO ADHESIVO  
ABBELLIMENTO ADESIVO

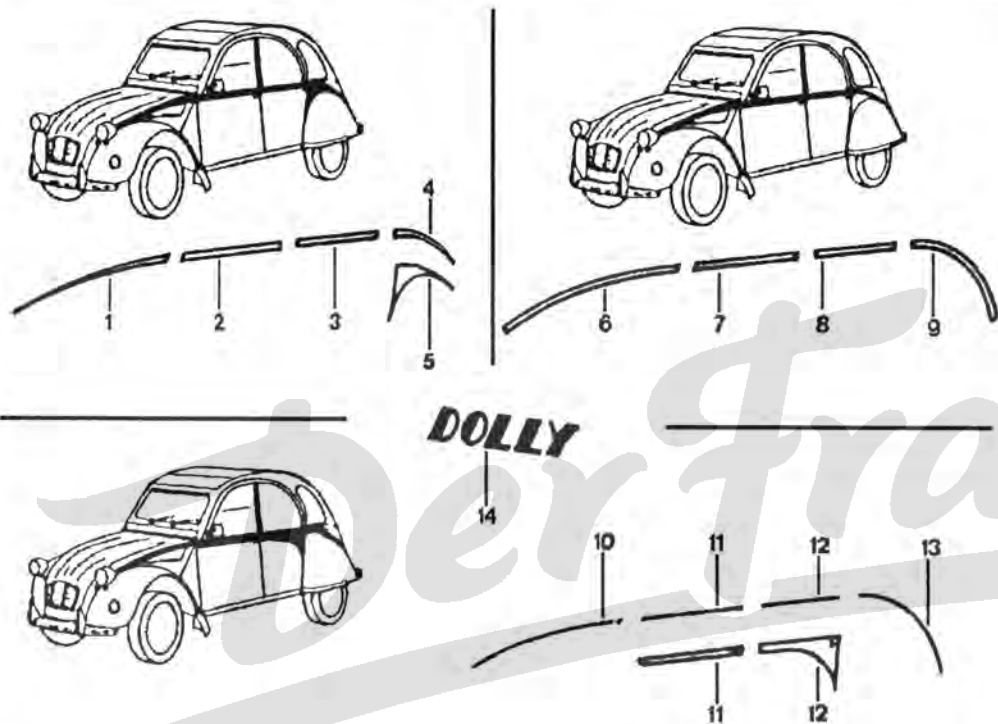

1115

[08 '86]

Z.854.40

Z8542400

**DOLLY**

11	<b>95 613 818 EWT</b>	02	SUP-AV-3POS	DECOR ADHESIF KLEBEZIERSTUECK ADHESIVE STRIP DECORADO DECORAZ.ADESIVA
	<b>95 613 569 EWT</b>	01	G- INF-AV-3POS	.
	<b>95 613 568 EWT</b>	01	D- INF-AV-3POS	.
	<b>95 613 818 EKB NFP</b>	02	SUP-AV-4POS	.

11	<b>95 613 569 EKB NFP</b>	01	D- INF-AV-4POS	DECOR ADHESIF KLEBEZIERSTUECK ADHESIVE STRIP DECORADO DECORAZ.ADESIVA
	<b>95 613 568 EKB</b>	01	D- INF-AV-4POS	.
	<b>95 613 818 EKA NFP</b>	02	AV-SUP-5POS	.
	<b>95 613 569 EKA NFP</b>	01	G- INF-AV-5POS	.
	<b>95 613 568 EKA NFP</b>	01	D- INF-AV-5POS	.
	<b>95 613 818 ERJ</b>	02	SUP-AV-6POS	.
	<b>95 613 569 ERJ</b>	01	D- INF-AV-6POS	.
	<b>95 613 568 ERJ</b>	01	D- INF-AV-6POS	.
	<b>95 613 818 EAA</b>	02	AV-SUP-7POS	.
	<b>95 613 569 EAA</b>	01	G- AV-INF-7POS	.
	<b>95 613 568 EAA</b>	01	D- AV-INF-7POS	.
12	<b>95 613 819 EWT RP 95613818EWT</b>	02	SUP-AR-3POS	.
	<b>95 613 571 EWT NFP</b>	01	G- INF-AR-3POS	.
	<b>95 613 570 EWT</b>	01	D- INF-AR-3POS	.
	<b>95 613 819 EKB NFP</b>	02	SUP-AR-4POS	.
	<b>95 613 571 EKB NFP</b>	01	G- INF-AR-4POS	.
	<b>95 613 570 EKB</b>	01	D- INF-AR-4POS	.
	<b>95 613 819 EKA NFP</b>	02	SUP-AR-5POS	.
	<b>95 613 571 EKA</b>	01	G- INF-AR-5POS	.
	<b>95 613 570 EKA NFP</b>	01	D- INF-AR-5POS	.

...J...

**DECORS ADHESIFS**  
KLEBEVERZIERUNG  
ADHESIVE EMBELLISHMENT  
EMBELLECIMIENTO ADHESIVO  
ABBELLIMENTO ADESIVO

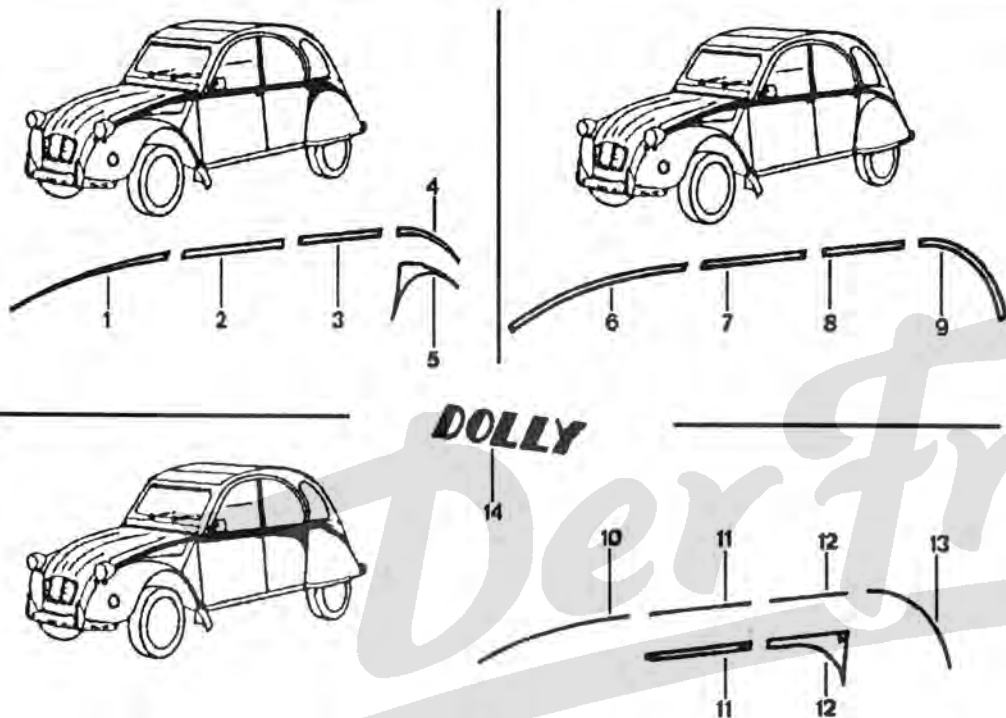

1115

[06 '98]

Z.854.40

Z8542400

**DOLLY**

12	95 613 819 ERJ RP 95613818ERJ	02 SUP-AR-6POS	DECOR ADHESIF KLEBEZIERSTUECK ADHESIVE STRIP DECORADO DECORAZ.ADESIVA
	95 613 571 ERJ	01 G- INF-AR-6POS	.
	95 613 570 ERJ	01 D- INF-AR-6POS	.
	95 613 819 EAA RP 95613818EAA	02 AR-SUP-7POS	.
	95 613 571 EAA	01 G- AR-INF-7POS	.

12	95 613 570 EAA	01 D- AR-INF-7POS	DECOR ADHESIF KLEBEZIERSTUECK ADHESIVE STRIP DECORADO DECORAZ.ADESIVA
13	95 613 573 EWT NFP	01 G- AR-3POS	.
	95 613 572 EWT	01 D- AR-3POS	.
	95 613 573 EKB	01 G- AR-4POS	.
	95 613 572 EKB NFP	01 D- AR-4POS	.
	95 613 573 EKA	01 G- AR-5POS	.
	95 613 572 EKA NFP	01 D- AR-5POS	.
	95 613 573 ERJ	01 G- AR-6POS	.
	95 613 572 ERJ	01 D- AR-6POS	.
	95 613 573 EAA	01 G- AR-7POS	.
	95 613 572 EAA	01 D- AR-7POS	.
14	95 613 555 FXX	01 "DOLLY"	MONOGRAMME AR NAMENZUG HINTEN REAR NAME-PLATE MONOGRAMA AR MONOGRAMMA POST
	95 613 555 EAA	01 "DOLLY"	.
	95 613 555 EKB	01 "DOLLY"	.
	95 613 555 EKA NFP	01 "DOLLY"	.
	95 613 555 ERJ NFP	01 "DOLLY"	.
	95 613 555 EWT NFP	01 "DOLLY"	.

15/02/91  
 1117 07-8542-50  
 PAGE : 1  
 D02 ↓

**DECORS ADHESIFS**  
 KLEBEVERZIERUNG  
 ADHESIVE EMBELLISHMENT  
 EMBELLECIMIENTO ADHESIVO  
 ABBELLIMENTO ADESIVO

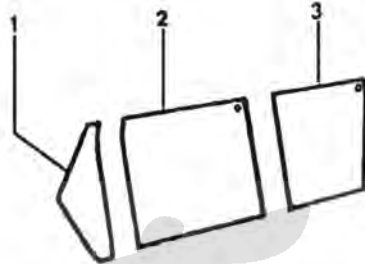

2 CV cocorico → 4

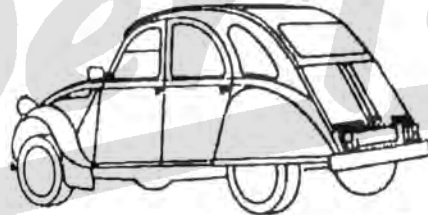

5  
 CITROËN

1118

11/781

Z864.50

Z8542500

**COCORICO**  
 ▶ 3584

01	96 003 869	01 G-	DECOR ADHESIF KLEBEZIERSTREIF ADHESIVE TAPE DECORADO DECORAZ.ADESIVA
	96 003 870	01 D	.
02	96 003 871	01 G- AV	.
	96 003 872	01 D- AV	.
03	96 003 873	01 G- AR	.

03  
04  
05

96 003 874  
96 003 876  
96 003 875

01 D- AR  
01 D-  
01 G-

DECOR ADHESIF  
KLEBEZIERSTREIF  
ADHESIVE TAPE  
DECORADO  
DECORAZ.ADESIVA  
  
 MONOGRAMME AR  
NAMENZUG HINTEN  
REAR NAME-PLATE  
MONOGRAMA AR  
MONOGRAMMA POST



**PLANCHE DE BORD**  
 ARMATURENBRETT-GERUST  
 DASHBOARD  
 PLANCHA ABORDO-ARMAZON  
 CRUSCOTTO-ARMATURA

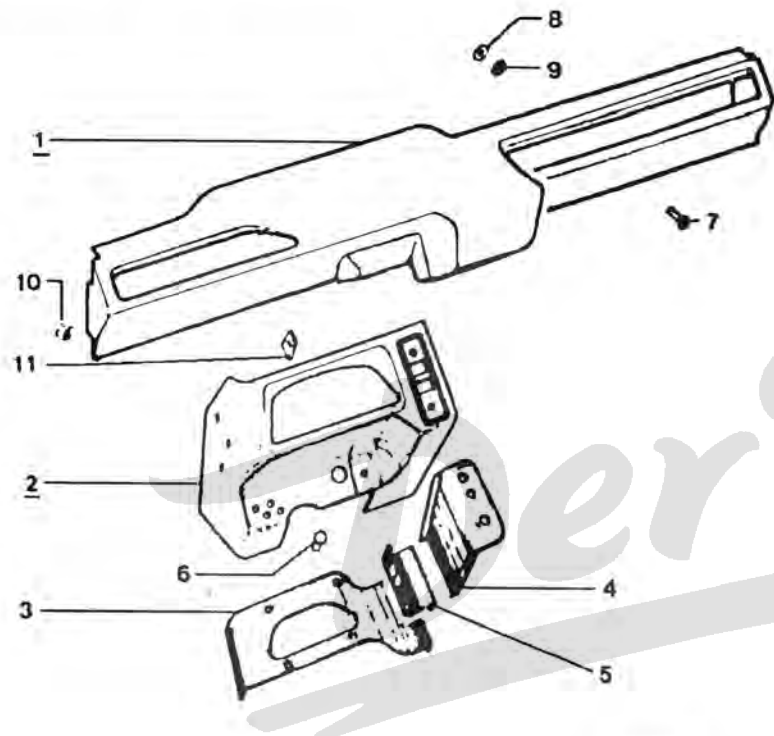

1117

[6/89]

07-8560 10

Z8560100

95 569 142\*700

01 SUP  
 RMP 5440871700

1605 ▶

**PLANCHE DE BORD**  
 ARMATURENBRETT  
 FACIA PANEL  
 TABLERO  
 CRUSCOTTO

5 485 879\*700

01 RMP 5457026700

**BOITIER**  
 GEHAEUSE  
 CLUSTER HOUSING  
 CAJA ENSAMBLADA  
 SCATOLA

03	5 416 719	01		SUPPORT COMBINE HALTER CLUSTER BRACKET SOPORTE SUPPORTO
04	AZ 822 235 A	01		-
05	AZ 822 52	01		-
06	5 500 852*706	03	DIAM 10,2X14-H:11 NOIR	OBTURATEUR STOPFEN FACIA PNL PLUG OBTURADOR TAPPO
07	20 960 009 RP 7903016256	03	4,85X19	VIS TFB METALISCHRAUBE METAL SCREW TORNILLO METAL VITE
	79 03 016 208 RP 7903016414	06	DIAM 4,8X19 RMP 22303019	VIS TOLE TCB BLECHSCHRAUBE TAPPING SCREW TORNILLO CHAPA VITE
08	79 03 053 372	06	DIAM 5X16 RMP 22303019	RONDELLE PLATE FLACHSCHEIBE PLAIN WASHER ARANDELA PLANA RONDELLA PIATTA
09	79 03 058 027	06	DIAM 5X12X1,2	RONDELLE A DENT ZAHNSCHEIBE SPRING WASHER ARANDELA RONDELLA DENTAT
10	26 157 129	10	CLIP	ECROU MUTTER NUT TUERCA DADO
11	26 157 109 RP 7903040037	04	1POS-CLIP DIAM4,85	ECROU TOLE BLECHMUTTER SPEED NUT TUERCA CHAPA DADO LAMIERA

.../...

15/02/91  
1117 07-8560-10  
PAGE : 2  
E01 ↑

**PLANCHE DE BORD**  
ARMATURENBRETT-GERUST  
DASHBOARD  
PLANCHA ABORDO-ARMAZON  
CRUSCOTTO-ARMATURA

52

5 485 879\*700

01 -(N)

**BOITIER**  
GEHAEUSE  
CLUSTER HOUSING  
CAJA ENSAMBLADA  
SCATOLA

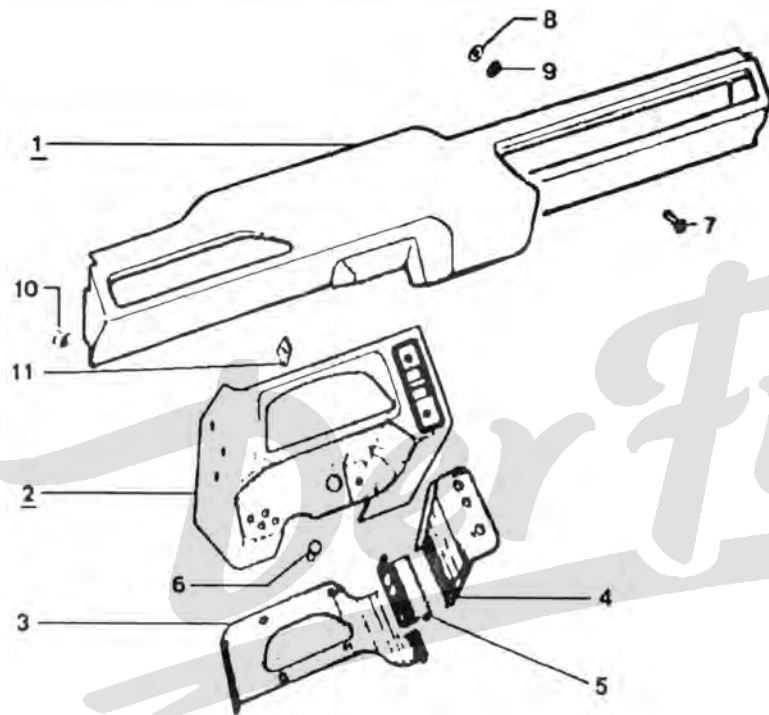

95 546 180\*700

01 -(D) -(A) 11/79 ▶

1117

[6/89]

07-8560 10

Z8560100

51

5 485 476\*700

01 SUP  
-CAD

**XT**

**PLANCHE DE BORD**  
ARMATURENBRETT  
FACIA PANEL  
TABLERO  
CRUSCOTTO

**SERRURES ET POIGNEES**  
**TUERSCHLOESSER UND GRIFFE**  
**LOCKS AND HANDLES**  
**CERRADURAS -MANECILLAS**  
**SERRATURE -MANIGLIE**

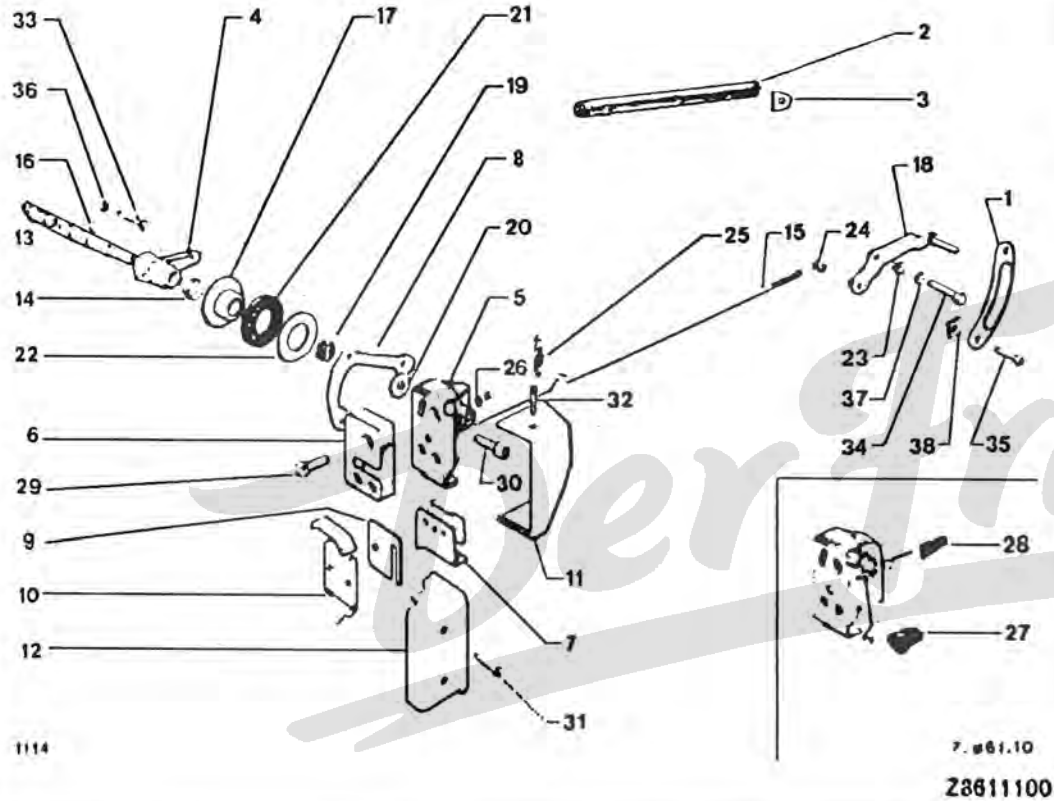

01	95 595 234 VC	01 G.	ENJOLIVEUR ZIERSTUECK HANDLE MOULDING EMBELLEDOR PROFILO
	95 595 234 XA	01 G.	-
	95 595 236 VC	01 D.	-
	95 595 236 XA	01 D.	-

02	95 595 138 VC	02	POIGNEE TIRAGE ZUGGRIF PULL HANDLE TIRADOR PROFILO
	95 595 138 FXX	02	-
03	AZ 841 126	04	EMBOUT ENDSTUECK SOCKET TOOL TERMINAL TERMINALE
	AZ 861 76 E	02 AV	POIGNEE TIRAGE ZUGGRIF PULL HANDLE TIRADOR TERMINALE
	95 599 231	02 ENS-"PAM"-AV	POIGNEE GRIF DOOR HANDLE EMPUNADURA MANIGLIA
	5 410 760	02 AR	-
05	5 410 738	01 G. AV	SERRURE PORTE TUERVERSCHLUSS DOOR LOCK CERRADURA PTA SERRATURA
	5 410 739	01 D. AV	-
	5 454 722	01 G. AR	-
	5 454 723	01 D. AR	-
06	5 451 522	02 G.	BOITIER GEHAEUSE DOOR LOCK BOX PROTECTOR SCATOLA
	5 451 523	02 D.	-
07	5 410 744	02 G.	GACHE SERRURE SCHLOSSFALLE LOCK STRIKER ARIELLA STAFFA SERRATUR
	5 410 745	02 D.	-

.../...

15/02/91  
1117 07-8611-10  
PAGE : 2  
E03 ↑

**SERRURES ET POIGNEES**  
TUERSCHLOESSER UND GRIFFE  
LOCKS AND HANDLES  
CERRADURAS -MANECILLAS  
SERRATURE -MANIGLIE

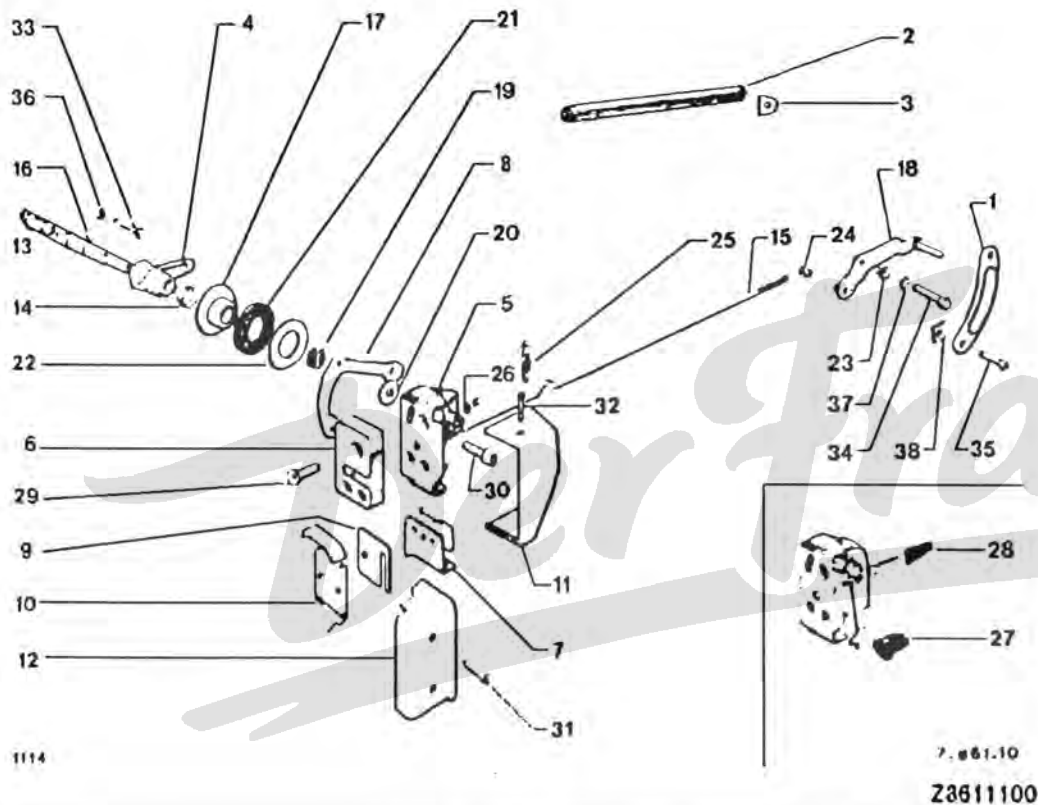

08 5 480 796

04

PLAQUE  
BEF.-PLATTE  
STRIK FIX PLATE  
PLACA  
PIASTRA FISS.

09 5 410 751

99 E 1-40X35.5

CALE DE GACHE  
FALLENUNTERLAGE  
LATCH SHIM  
CALA DE ARMELLA  
SPESSORE BOCCHIE

10	5 410 750	04	PLAQUETTE GEWINDEPLAKETTE TAPPED PLATE PLAQUETA PLACCHETTA
11	5 410 753 NFP	02 AV	BOITIER GEHAEUSE DOOR LOCK BOX PROTECTOR SCATOLA
	5 486 232*700	02	LAT-AV -SPECIALE
	5 486 233*700	01	G- LAT-AR -SPECIALE
	5 486 234*700	01	D- LAT-AR -SPECIALE
12	5 476 943*700	04	-SPECIALE
13	A 861 35	01	RONIS RMP 5441230 (JOURNEE)
	5 410 765	01	ENS DE 3 RONIS RMP 5441233 (JOURNEE)
	AU 861 13 A	01	RONIS -SPECIALE RMP 5490663
	AZ 861 34	04	JEU DE VERROUS SCHLOESSERSATZ DOOR LOCK SET JUEGO BOMBILLOS SERIE CHIAVIST.
14	AZ 861 34	04	RESSORT FEDER LOCKING SPRING MUELLE MOLLA
15	AZ 861 171 A	02	TIGE CONDAMNAT VERRIEG.STANGE LOCK-OUT PIN VARILLA MANDO ASTA COMANDO
16	5 410 758	02	BROCHE SPINDELSTIFT PIN CONECTOR MANDRINO

15/02/91  
1117 07-8611-10  
PAGE : 3  
E04 ↑

**SERRURES ET POIGNEES**  
TUERSCHLOESSER UND GRIFFE  
LOCKS AND HANDLES  
CERRADURAS -MANECILLAS  
SERRATURE -MANIGLIE

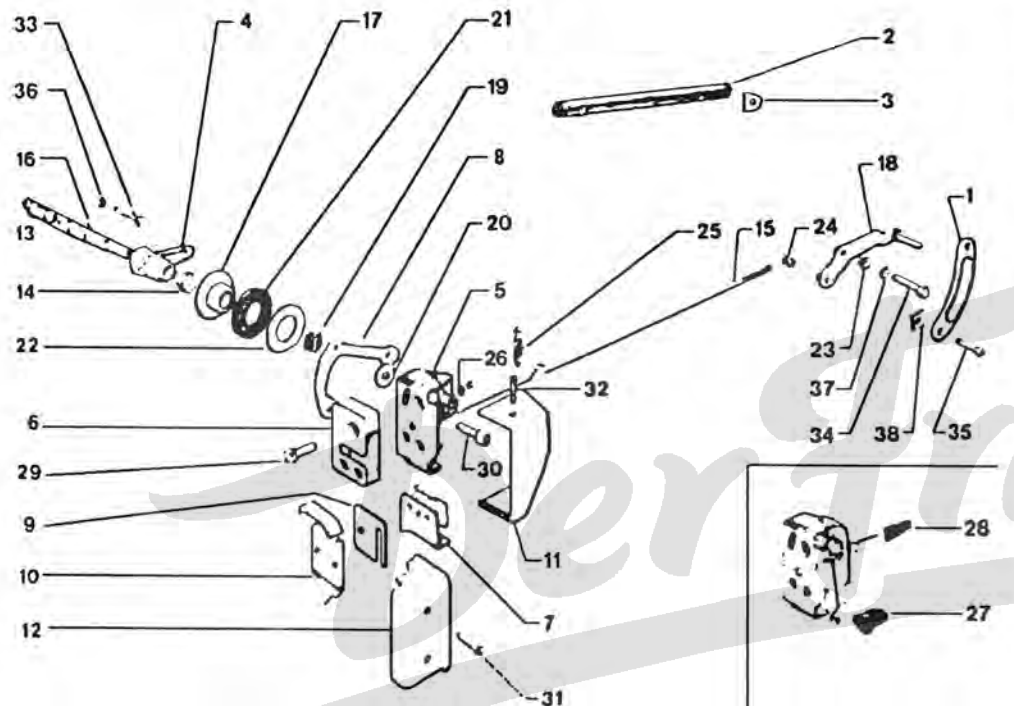

1114

7. 861.10  
Z8611100

19	5 412 058	02	CAOUTCHOUC	BUTEE POIGNEE ANSCHLAG HANDLE BUFFER TOPE EMPUNADURA CUSCINETTO
20	5 412 060	04		ENTRETOISE ABSTANDSSTUECK SPACER JUEGO DISTANCIA DIZANZIALE
21	95 585 468	04	23X45X6 CAOUTCHOUC	RONDELLE ETC DICHTSCHEIBE SEAL WASHER ARANDELA RONDELLA
22	AZ 861 91 A	04	"NYLON" 23X46X1	-
23	AZ 861 131	02		BAGUE CENTRAGE ZENTRIERRING CENTRING BUSH CASQUILLO CENT. BOCCOLA CENTRAG
24	AZ 861 141	02		BARILLET VERROU EINSATZ LOCK BARREL BOMBILLO CERRAD BARILETTO
25	AZ 861 123	02		RESSORT RUCKZUGFEDER RETURN SPRING MUELLE MOLLA RICHIAMO
26	D 615 73	02	CAOUTCHOUC	RONDELLE CAOUT. GUMMISCHEIBE RUBBER WASHER ARANDELA GOMA RONDELLA
27	5 442 477	01	G- AR	BOUTON KNOPF LOCK BUTTON BOTON BOTTONE
	5 442 478	01	D- AR	-
28	5 437 319	02	AR	EMBOUIT LEVIER HEBELENDSTUECK LEVER END-PIECE TERMINAL TERMINALE LEVA

17	AZ 861 75 A	04	16X48X17,5	COUPELLE TELLER CUP COPELA SCODELLINO
18	AZ 861 81	01	G-	LEVIER DE CDE HEBEL CONTROL LEVER LEVA MANDO LEVA
	AZ 861 81 A	01	D-	-

.../...

15/02/91  
1117 07-8611-10  
PAGE : 4  
E05 ↑

**SERRURES ET POIGNEES**  
TUERSCHLOESSER UND GRIFFE  
LOCKS AND HANDLES  
CERRADURAS -MANECILLAS  
SERRATURE -MANIGLIE

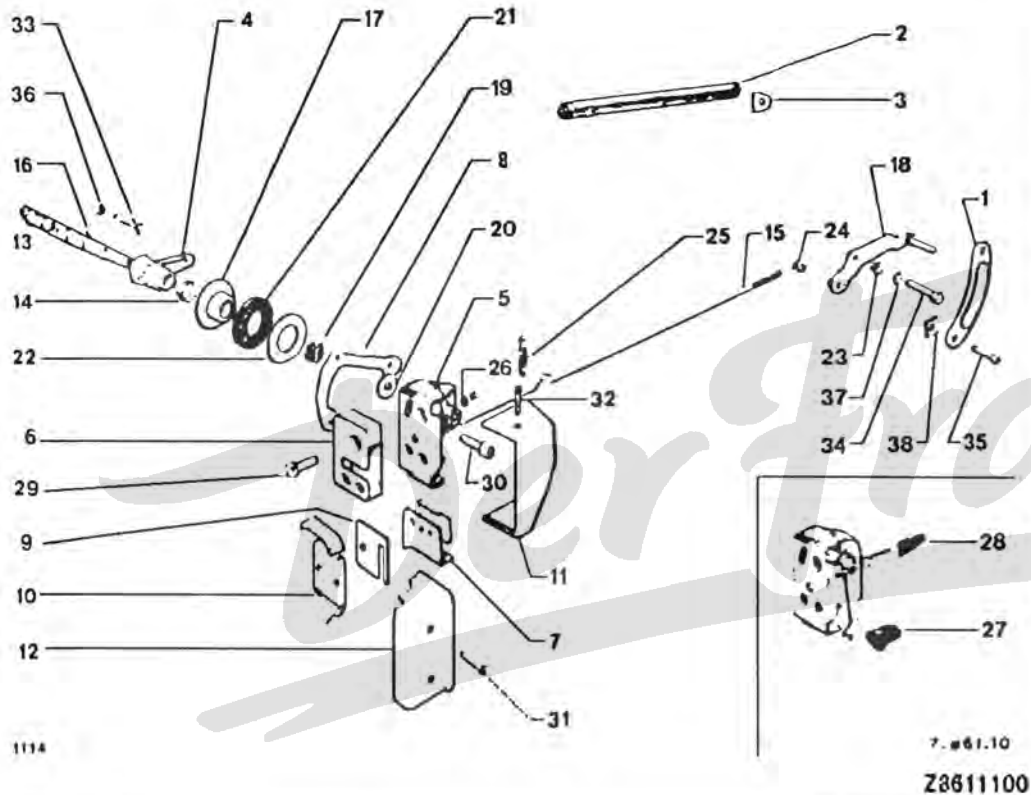

1114

7. 861.10  
Z8611100

29	5 451 524	12	TH 6X25	VIS DE SERRURE SCHLOSSSCHRAUBE LOCK FIX SCREW TORNILLO VITE SERRATURA	30	26 214 149	12	DIAM6X100	▶ 06/80	VIS CHC SCHRAUBE SOCKET SCREW TORNILLO CHC VITE TESTA
	26 214 199	08	6X25	▶ 06/80	31	79 03 007 054	12	TCB 6X100-16	06/80 ▶	VIS TOLE TCB BLECHSCHRAUBE TAPPING SCREW TORNILLO CHAPA VITE
	79 03 004 031 RP 26214199	08	6X25	06/80 ▶	32	79 03 016 198 RP 20964009	08	TFB 3 5X9,5		VIS TOLE TF BLECHSCHRAUBE TAPPING SCREW TORNILLO R CHAP VITE LAMIERA
					33	79 03 005 061	08	4X12		VIS TFB METALISCHRAUBE METAL SCREW TORNILLO METAL VITE
					34	79 03 201 010	04	TH 5X0,8-10 RMP 7903101053		VIS TH SCHRAUBE CAPSCREW TORNILLO TH VITE
					35	79 03 201 130	02	DIAM 5 X 0,80 - 16 RMP 7903101283		
					36	79 03 016 117 RP 7903016256	04	TFB4,85X19 RMP 22745009		VIS TOLE TF BLECHSCHRAUBE TAPPING SCREW TORNILLO R CHAP VITE LAMIERA
					37	79 03 053 372	04	DIAM 5X16 RMP 22745009		RONDELLE PLATE FLACHSCHEIBE PLAIN WASHER ARANDELA PLANA RONDELLA PIATTA
					38	ZC 9624 024 Z	02			RONDELLE SCHEIBE RUBBER WASHER ARANDELA RONDELLA
						26 157 579	04	CLIP		ECROU MUTTER NUT TUERCA DADO



15/02/91  
 1117 07-9616-10  
 PAGE : 1  
 E07 ↑

**GLACES - ENCADREMENT AVANT**  
 VORDERE TUEFENSTER  
 FRONT DOOR WINDOWS  
 VENTANAS DE PUERTAS DELANTERAS  
 FINESTRE PORTIERE ANT.

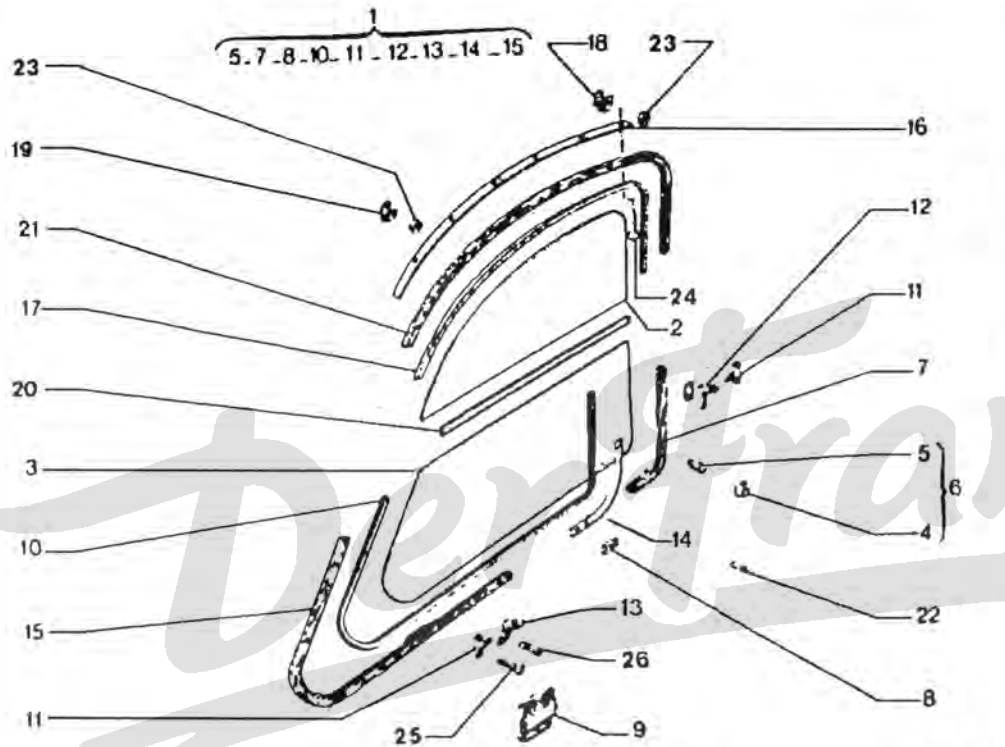

1117

[6/89]

7.9616 10

Z9616100

03	A 961 5	02	VITRE PORTE AV SCHEIBE FRT DOOR GLASS LUNA PUERTA VETRO PORT.ANT.
04	AZ 961 53	01 G-	VERROU DE VITRE SCHEIBENRIEGEL SIDE WINDW LOCK CERROJO DE LUNA CHIAVISTELLO
	AZ 961 53 A	01 D-	-
05	5 503 677	02	DOIGT VERRQUIL ZAPPEN LOCKING FINGER DEDO BLOQUEO NOTTOLINO
06	5 504 387	01 G-	VERROU DE VITRE SCHEIBENRIEGEL SIDE WINDW LOCK CERROJO DE LUNA CHIAVISTELLO
	5 504 388	01 D-	-
07	AZ 961 55	01 G- AR	ENCADREMENT RAHMEN WINDOW FRAME MARCO DE LUNA INTELAIAURA
	AZ 961 55 A	01 D- AR	-
08	AZ 961 60	02 2DIAM 4,5	COUVRE JOINT ABDECKLEISTE GASKET COVER CUBRE JUNTA COPRIGUARNIZ
09	95 540 094	02 ENT 60	VERROU DE VITRE SCHEIBENRIEGEL SIDE WINDW LOCK CERROJO DE LUNA CHIAVISTELLO
10	A 961 83	02 INF-LON 1050	ENCADREMENT RAHMEN WINDOW FRAME MARCO DE LUNA INTELAIAURA
01	5 429 796	01 G- "PAM" INF	ENCADREMENT RAHMEN WINDOW FRAME MARCO DE LUNA INTELAIAURA
	5 429 797	01 D- "PAM" INF	-
02	A 961 4	02	VITRE PORTE AV SCHEIBE FRT DOOR GLASS LUNA PUERTA VETRO PORT.ANT.



**GLACES - ENCADREMENT AVANT**  
VORDERE TUERFENSTER  
FRONT DOOR WINDOWS  
VENTANAS DE PUERTAS DELANTERAS  
FINESTRE PORTIERE ANT.

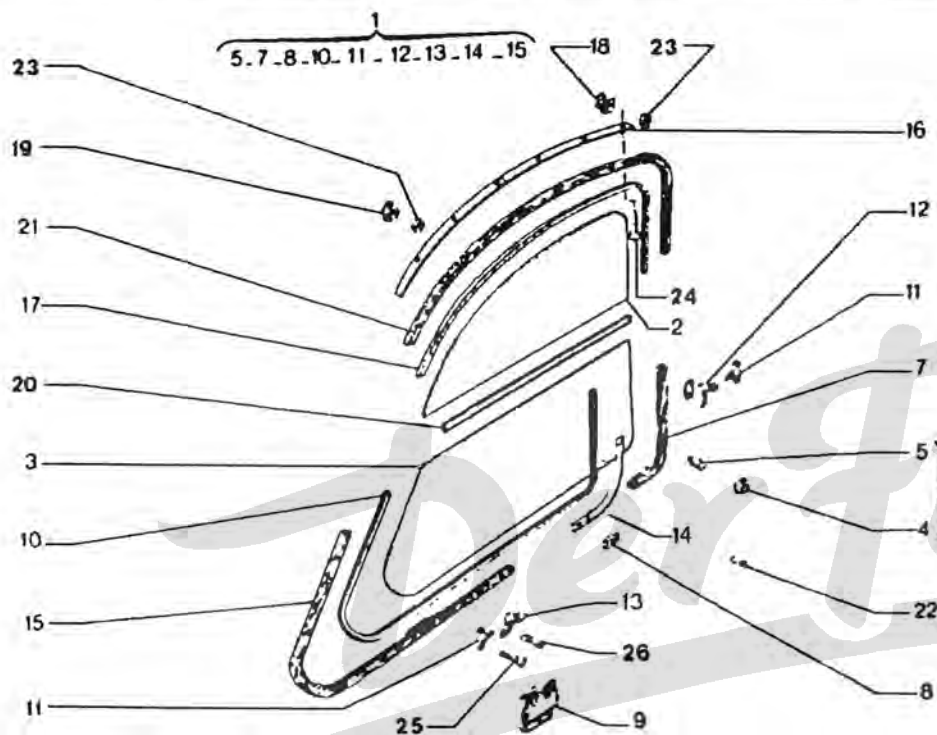

1117

[6/89]

7.9616 10

Z9616100

11	95 561 038	04	RMP AZ96134	1515 ▶	AXE DE VITRE ACHSE GLASS PIN EJE DE LUNA PERNO
12	AZ 961 85	02	AR-2 DIAM 4,5		EMBOUT ENDSTUECK SOCKET TOOL TERMINAL TERMINALE
13	AZ 961 86	01	G- AV-2 DIAM 4,5		-

13	AZ 961 86 A	01	D- AV-2 DIAM 4,5		EMBOUT ENDSTUECK SOCKET TOOL TERMINAL TERMINALE
14	AZ 961 87	02	2 DIAM 4.5		FINITION ZIERSTUECK FRAME COVERING ACABADO MARCO FINITURA
15	AZ 961 89	01	G- INF-AV		JOINT DE VITRE DICHTUNG WINDOW JOINT JUNTA DE LUNA GUARNIZIONE
	AZ 961 89 A	01	G- D-INF-AV		-
16	A 961 90	02	SUP-LON 730		-
17	A 961 91	02	SUP-LON 710		-
18	95 638 246	01	G- AR 3553 ▶		BUTEE ANSCHLAG FRAME BUFFER TOPE MARCO CUSCINETTO
	95 638 245	01	D- AR 3553 ▶		-
19	95 638 244	01	G- AV 3553 ▶		-
	95 638 243	01	D- AV 3553 ▶		-
20	75 515 854	02	LON 488		ETANCHEITE ABDICHTUNG SEALING ESTANQUEIDAD TENUTA
21	AZ 961 97	01	G- SUP		JOINT DE VITRE DICHTUNG WINDOW JOINT JUNTA DE LUNA GUARNIZIONE
	AZ 961 97 A	01	D- SUP		-
22	AZ 961 108	02	5,5X20		BROCHE SPINDELSTIFT PIN CONECTOR MANDRINO

.../...

15/02/91  
 1117 07-9616-10  
 PAGE : 3  
 E09 ↑

**GLACES - ENCADREMENT AVANT**  
 VORDERE TUEFENSTER  
 FRONT DOOR WINDOWS  
 VENTANAS DE PUERTAS DELANTERAS  
 FINESTRE PORTIERE ANT.

25  
 26

20 262 009  
 RP 7903022009

08 TF 4X12

VIS TF  
 SCHRAUBE  
 CAPSCREW  
 TORNILLO  
 VITE

95 561 037

04

1515 ▶

EMBOU  
 ENDSTUECK  
 SOCKET TOOL  
 TERMINAL  
 TERMINALE

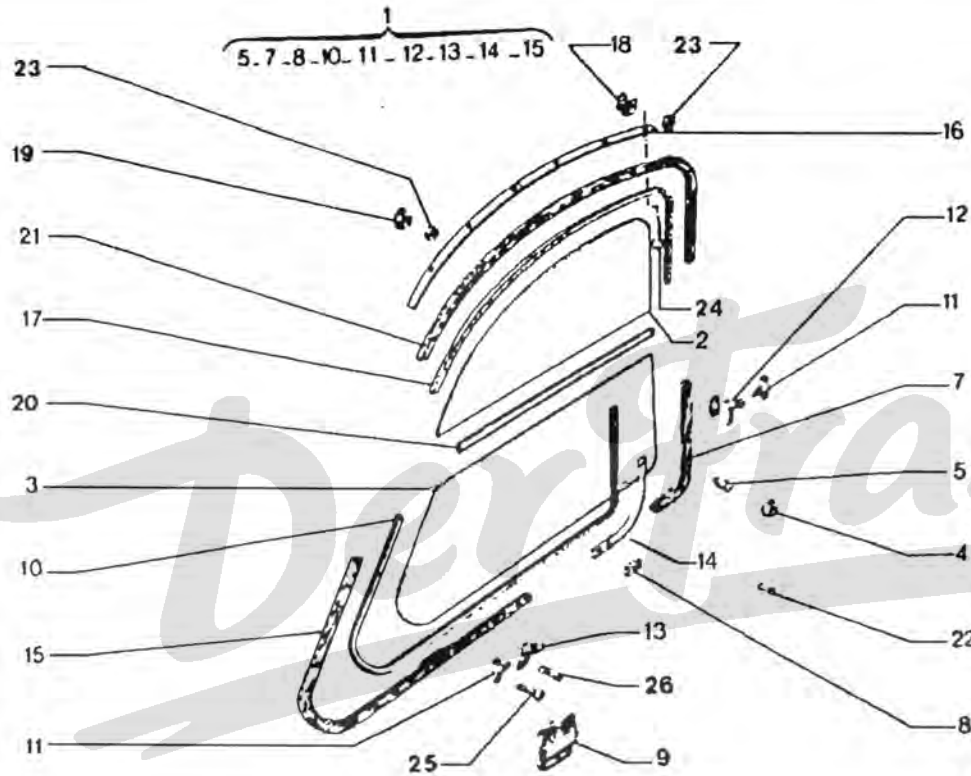

1117

[6/89]

7-9616 10

Z9616100

23 ZD 9226 900 Z

04 HE 4X0,75

ECROU HEXAGONAL  
 SECHSKANTMUTTER  
 HEXAGONAL NUT  
 TUERCA  
 DADO ESAGONALE

24 ZD 9226 400 Z

10 TA 3,5X20

VIS TOLE TCB  
 BLECHSCHRAUBE  
 TAPPING SCREW  
 TORNILLO CHAPA  
 VITE

NUMERO	SOUS-GROUPE	REP	NUMERO	SOUS-GROUPE	REP	NUMERO	SOUS-GROUPE	REP	NUMERO	SOUS-GROUPE	REP
402 260	07-0080-10	02	5 451 522	07-8611-10	06	75 514 348	07-0080-10	59	95 592 907		04
403 067	07-7460-10	05	5 451 523		06	75 514 349		59	95 592 908	07-8450-10	03
403 072		03	5 451 524		29	75 515 854	07-9616-10	20	95 592 909	07-8453-20	07
403 073		01	5 452 347	07-8501-10	01	75 519 741	07-8450-10	22	95 592 911		06
403 085	07-0080-10	54	5 452 350		02	75 524 607	07-0080-10	09	95 593 160	07-0080-10	20
		04	5 452 353		05	75 524 608		09	95 593 161		20
403 269		22	5 452 629	07-0080-10	12	75 525 041	07-9615-20	53	95 593 840	07-8542-30	07
403 355	07-7460-10	06	5 452 990	07-8515-20	02	95 495 801	07-8410-10	08	95 593 841		06
403 969	07-0080-10	23	5 454 450	07-8410-10	02	95 495 802		58	95 593 842		01
410 548		19	5 454 451		02	95 495 803		08	95 593 843		01
410 549		19	5 454 722	07-8611-10	05	95 539 529	07-8515-20	07	95 593 844		05
410 738	07-8611-10	05	5 454 723		05	95 540 094	07-9616-10	09	95 593 845		05
410 739		05	5 455 442	07-0080-10	05	95 551 416	07-0080-10	16	95 593 846		04
410 744		07	5 458 377	07-7460-10	08	95 559 829	07-9615-20	08	95 593 847		04
410 745		07	5 458 865	07-0080-10	58	95 561 037	07-9616-10	26	95 593 848		03
410 750		10	5 458 866		56		07-8410-10	85	95 593 849		03
410 751		09	5 462 716	07-8410-10	01	95 561 038	07-9616-10	11	95 593 852		02
410 753		11	5 462 717		01	95 561 039	07-8410-10	57	95 593 853		02
410 758		18	5 468 191	07-8450-10	12	95 561 040		57	95 595 539	07-0080-10	01
410 760		04	5 478 655		14	95 561 118		07	95 595 540		51
410 765		13	5 480 221	07-8501-10	06	95 561 119		07	95 595 684	07-8453-20	09
	07-8450-10	09	5 480 796	07-8611-10	08	95 565 400	07-0080-10	16	95 596 361		03
411 382	07-8510-10	04	5 485 498	07-0080-10	62	95 570 109	07-9615-20	01	95 599 231	07-8511-10	04
411 383		04	5 485 508		53	95 575 886		04	95 600 318	07-8450-10	07
411 500		04	5 488 445	07-8410-10	22	95 575 892		03	95 601 238	07-8453-20	11
411 501		04	5 489 177	07-8501-10	80	95 575 902		02	95 602 794	07-8510-10	02
412 058	07-8611-10	19	5 500 614	07-0080-10	07	95 576 406	07-0080-10	11	95 613 556	07-8542-40	01
412 080		20	5 500 615		07	95 576 413		61	95 613 557		01
412 387	07-7460-10	13	5 501 036	07-8410-10	77	95 577 428	07-8510-10	58	95 613 558		02
413 142	07-8501-10	22	5 503 677	07-9616-10	05	95 577 429		58	95 613 559		02
413 825	07-8410-10	04	5 504 387		06	95 578 708	07-8450-10	02	95 613 561		03
418 719	07-8560-10	03	5 504 388		08	95 579 369		08	95 613 562		05
418 099	07-0080-10	21	20 262 002		25	95 579 370		08	95 613 563		05
418 100		21	20 960 009	07-8560-10	07	95 579 371		08	95 613 564		04
419 320	07-7460-10	07	23 828 019	07-7460-10	15	95 579 372		08	95 613 565		04
419 946	07-8450-10	20	26 130 459	07-0080-10	24	95 579 373	07-8542-10	08	95 613 574		06
	07-8501-10	16	26 130 638	07-8410-10	29	95 580 258	07-8501-10	12	95 613 575		06
420 639		13	26 157 109	07-8560-10	11	95 582 670	07-8542-20	01	95 613 576		07
424 742	07-8410-10	24	26 157 129		10	95 582 671		02	95 613 577		07
424 743		25	26 157 579	07-8611-10	38	95 582 674		03	95 613 579		08
427 281	07-8501-10	14	26 157 619	07-8501-10	27	95 582 675		04	95 613 580		09
429 796	07-9616-10	01	26 157 969	07-8453-20	20	95 584 060	07-8450-10	28	95 613 581		09
429 797		01	26 158 109	07-8515-20	08	95 585 468	07-8611-10	21	95 623 773	07-0080-10	26
431 122	07-8501-10	15	26 158 209	07-0080-10	28	95 588 535	07-9615-20	05	95 624 188	07-8410-10	06
434 286	07-0080-10	06	26 158 299		28	95 588 538		08	95 632 552	07-8501-10	18
434 287		06	26 211 169	07-8515-20	05	95 592 560	07-8453-20	01	95 638 243	07-9616-10	19
437 263	07-8410-10	18	26 214 149	07-8611-10	30	95 592 564		08	95 638 244		19
437 319	07-8611-10	28	26 214 199		29	95 592 565	07-8450-10	07	95 638 245		18
442 477		27	26 240 089	07-8501-10	26	95 592 567	07-8453-20	05	95 638 246		18
442 478		27	75 412 366	07-0080-10	18	95 592 903		02	96 003 869	07-8542-50	01
443 882	07-8515-20	02	75 511 478	07-8501-10	08	95 592 904		02	96 003 870		01

NUMERO	SOUS-GROUPE	REP	NUMERO	SOUS-GROUPE	REP	NUMERO	SOUS-GROUPE	REP	NUMERO	SOUS-GROUPE	REP
96 003 871		02	A 961 102	07-9615-20	09	AZ 861 141		24		07-8410-10	32
96 003 872		02	A 961 4	07-9616-10	02	AZ 861 171 A		15	79 03 016 208	07-8560-10	07
96 003 873		03	A 961 5		03	AZ 861 34		14	79 03 032 005	07-8453-20	19
96 003 874		03	A 961 83		10		07-8450-10	11	79 03 037 006	07-8410-10	30
96 003 875		05	A 961 90		16	AZ 861 75 A	07-8611-10	17	79 03 053 372	07-8501-10	25
96 003 876		04	A 961 91		17	AZ 861 76 E		04		07-8560-10	68
96 995 263	07-7460-10	04	AK 851 33	07-8501-10	09	AZ 861 81		18		07-8611-10	36
96 995 264		04	AK 861 37 B		10	AZ 861 81 A		18	79 03 056 005	07-8501-10	23
96 995 274		02	AK 861 70		11	AZ 861 89	07-8450-10	16	79 03 058 027	07-8453-20	16
96 995 278	07-8450-10	01	AU 861 13 A	07-8611-10	13	AZ 861 91 A	07-8611-10	22		07-8560-10	09
96 995 279	07-8510-10	01	AY 831 102 A	07-7480-10	14	AZ 961 108	07-9616-10	22	79 03 058 038	07-8453-20	17
96 995 280		01	AY 833 85	07-0080-10	13	AZ 961 32	07-9615-20	04		07-8501-10	24
96 995 318	07-8450-10	10	AY 861 390 A	07-8450-10	17	AZ 961 53	07-9616-10	04	79 03 072 083	07-0080-10	31
5 413 823*700	07-8410-10	03	AY 861 57		13	AZ 961 53 A		04	79 03 072 163	07-8510-10	06
5 413 824 XA		04	AZ 821 106	07-0080-10	08	AZ 961 55		07	79 03 072 243	07-8453-20	12
5 424 915*700		20	AZ 821 125 A		29	AZ 961 55 A		07		07-8410-10	28
5 450 124 VA		09	AZ 821 78	07-8410-10	21	AZ 961 60		08	79 03 072 287	07-8453-20	12
5 450 125 VA		09	AZ 822 235 A	07-8560-10	04	AZ 961 74	07-9615-20	07	79 03 074 015		10
5 450 129 VA		10	AZ 822 52		05	AZ 961 85	07-9616-10	12	79 03 074 050	07-7460-10	13
5 450 130 VA		10	AZ 831 294 A	07-0080-10	30	AZ 961 86		13	79 03 074 118	07-0080-10	25
5 476 943*700	07-8611-10	12	AZ 841 108 A	07-8410-10	19	AZ 961 86 A		13	79 03 080 036	07-8450-10	27
5 485 476*700	07-8560-10	51	AZ 841 110 A		14	AZ 961 87		14		07-8453-20	18
5 485 879*700		52	AZ 841 121		23	AZ 961 89		15	79 03 101 771	07-8510-10	07
		02	AZ 841 126	07-8611-10	03	AZ 961 89 A		15		07-8410-10	30
5 486 232*700	07-8611-10	11	AZ 841 53	07-8410-10	11	AZ 961 97		21		07-0080-10	27
5 486 233*700		11	AZ 841 60		12	AZ 961 97 A		21	79 03 101 776		26
5 486 234*700		11	AZ 841 79	07-0080-10	14	AZU 841 81	07-8410-10	06	79 03 201 010	07-8511-10	33
5 500 852*706	07-8560-10	06	AZ 841 79 A		14	D 615 73	07-8611-10	28	79 03 201 129	07-8453-20	15
A 813 87	07-0080-10	03	AZ 841 82 B		15	OS 983 81	07-0080-10	32		07-8450-10	25
A 821 72	07-7460-10	12	AZ 841 82 C		15	ZC 9615 602 U	07-8410-10	28	79 03 201 130	07-8515-20	06
A 821 72 A		12	AZ 844 123	07-8450-10	06	ZC 9615 805 U		28		07-8611-10	34
A 822 2	07-0080-10	10	AZ 844 24 A		03	ZC 9618 713 U	07-8501-10	20	85 548 180*700	07-8560-10	52
A 822 2 A		10	AZ 844 59		18	ZC 9618 829 U	07-8410-10	27	95 561 451 DA	07-8542-10	01
A 831 82	07-7460-10	09	AZ 844 64		19	ZC 9619 848 U	07-8515-20	04	95 561 451 KA		01
A 831 82 A		09	AZ 844 73		04	ZC 9624 024 Z	07-8611-10	37	95 561 451 VP		01
A 831 87		10	AZ 844 72 A		04	ZD 9222 400 Z	07-8450-10	24	95 561 452 DA		01
A 831 87 A		10	AZ 844 89		05	ZD 9226 400 Z	07-9616-10	24	95 561 452 KA		01
A 831 93		11	AZ 851 77	07-8515-20	06	ZD 9226 900 Z		23	95 561 452 VP		01
A 831 93 A		11	AZ 851 88 B		01	79 03 004 031	07-8611-10	29	95 561 452 DA		02
A 841 78	07-8410-10	13	AZ 851 88 C		01	79 03 004 037	07-8450-10	24	95 561 454 DA		02
A 842 88 B		05	AZ 852 151	07-8501-10	07	79 03 005 038		23	95 561 455 DA		03
A 842 86 C		05	AZ 852 211 A		08	79 03 005 061	07-8611-10	22	95 561 456 DA		03
A 842 94		26	AZ 852 5 A		04	79 03 007 054		30	95 561 457 DA		04
A 851 85 A	07-8510-10	05	AZ 852 62		03	79 03 007 072	07-8453-20	13	95 561 458 DA		04
A 851 86		03	AZ 852 62 A		03	79 03 007 094	07-8413-10	33	95 561 459 VA		01
A 851 87 A	07-8515-20	03	AZ 852 79		17	79 03 007 103	07-8450-10	26	95 561 459 VP		01
A 854 12	07-8410-10	16	AZ 852 60 A		19	79 03 007 147	07-8410-10	31	95 561 460 VA		01
A 854 18	07-0080-10	17	AZ 854 11	07-8410-10	15	79 03 008 142		34	95 561 460 VP		01
A 854 20	07-8410-10	17	AZ 861 123	07-8611-10	25	79 03 016 117	07-8611-10	35	95 561 461 VA		01
A 861 35	07-8611-10	13	AZ 861 124	07-8450-10	21	79 03 016 189	07-8501-10	21	95 561 461 VP		01
A 861 74	07-8450-10	15	AZ 861 131	07-8611-10	23	79 03 016 198	07-8611-10	31	95 561 462 VA		01

B05 ↑

INDEX

Catalogue 1117

NUMERO	SOUS-GROUPE	REP	NUMERO	SOUS-GROUPE	REP	NUMERO	SOUS-GROUPE	REP
95 561 462 VP		06						
95 561 463 VA		07	95 613 572 EKA		13			
95 561 464 KA		08	95 613 572 EKB		13			
95 569 142*700	07-8560-10	01	95 613 572 ERJ		13			
95 595 138 FXX	07-8611-10	02	95 613 572 EWT		13			
95 595 138 VC		02	95 613 573 EAA		13			
95 595 234 VC		01	95 613 573 EKA		13			
95 595 234 XA		01	95 613 573 EKB		13			
95 595 236 VC		01	95 613 573 ERJ		13			
95 595 236 XA		01	95 613 573 EWT		13			
95 613 555 EAA	07-8542-40	14	95 613 818 EAA		11			
95 613 555 EKA		14	95 613 818 EKA		11			
95 613 555 EKB		14	95 613 818 EKB		11			
95 613 555 ERJ		14	95 613 818 ERJ		11			
95 613 555 EWT		14	95 613 818 EWT		11			
95 613 555 FXX		14	95 613 819 EAA		12			
95 613 566 EAA		10	95 613 819 EKA		12			
95 613 566 EKA		10	95 613 819 EKB		12			
95 613 566 ERJ		10	95 613 819 ERJ		12			
95 613 566 EWT		10	95 613 819 EWT		12			
95 613 587 EAA		10	95 631 715 KA	07-8542-10	02			
95 613 587 EKB		10	95 631 715 VP		02			
95 613 587 ERJ		10	95 631 716 KA		02			
95 613 587 EWT		10	95 631 718 VP		02			
95 613 588 EAA		11	96 002 322 KA		03			
95 613 588 EKA		11	96 002 322 VP		03			
95 613 588 EKB		11	96 002 323 KA		03			
95 613 588 ERJ		11	96 002 323 VP		03			
95 613 588 EWT		11	96 002 324 KA		04			
95 613 589 EAA		11	96 002 324 VP		04			
95 613 589 EKA		11	96 002 325 KA		04			
95 613 589 EKB		11	96 002 325 VP		04			
95 613 589 ERJ		11						
95 613 589 EWT		11						
95 613 570 EAA		12						
95 613 570 EKA		12						
95 613 570 EKB		12						
95 613 570 ERJ		12						
95 613 570 EWT		12						
95 613 571 EAA		12						
95 613 571 EKA		12						
95 613 571 EKB		12						
95 613 571 ERJ		12						
95 613 571 EWT		12						
95 613 572 EAA		13						

15/02/91 1117 <b>TABLEAU DES VUES</b> AUFSTELLUNG DER BILDER TABLE OF PICTURE B01 ↑ <b>TABLA DE VISTAS</b> <b>TABELLA DELLE VEDUTE</b>	<b>GROUPE</b> <b>GROUP</b> <b>GROUP 08</b> <b>GRUPO</b> <b>GRUPPO</b>		<b>BANQUETTE AVANT - GARNITURE</b> <b>VORDERE SITZBANK - BEZUG</b> <b>FRONT BENCH SEAT - TRIMMING</b> <b>BANQUETA DELANTERA - GUARNECIDO</b> <b>SEDILE ANT. A 2 POSTI - RIVESTIMENTO</b>	9222-13	<b>C13</b>
<b>SOUS-GROUPE</b> <b>UNTERGRUPPE</b> <b>SUBGROUP</b> <b>SUBGRUPO</b> <b>SOTTOGRUPPO</b>	<b>NUMERO</b> <b>NUMMER</b> <b>NUMBER</b> <b>NUMERO</b> <b>NUMERO</b>	<b>VUE</b> <b>BILD</b> <b>PICTURE</b> <b>VISTA</b> <b>VEDUTA</b>	<b>BANQUETTE AVANT-ARMATURE</b> <b>VORDERE SITZE - ARMATUREN</b> <b>FRONT SEATS - FRAMES</b> <b>ASIENTOS DELANTEROS-ARMADURAS</b> <b>SEDILI ANTERIORI - ARMATURE</b>	9225-11	<b>C14 C15</b>
<b>PARE SOLEIL - RETROVISEUR INTERIEUR</b> <b>SONNENBLLENDE INNENRUECKSPIEGEL</b> <b>SUN VISOR - INSIDE REARVIEW MIRROR</b> <b>PARASOL-RETROVISOR INTERIOR</b> <b>PARASOLE-RETROVISORE INTERNO</b>	5541-10	<b>C02 C03</b>	<b>SIEGE AVANT - ARMATURE</b> <b>VORDERE SITZE - ARMATUREN</b> <b>FRONT SEATS - FRAMES</b> <b>ASIENTOS DELANTEROS-ARMADURAS</b> <b>SEDILI ANTERIORI - ARMATURE</b>	9225-21	<b>D15 D14</b> <b>D13</b>
<b>CEINTURES DE SECURITE AV A ENROULEUR</b> <b>VORDERE SICHERHEITSGURTE MIT WICKLERN</b> <b>FRONT SAFETY BELTS WITH WINDERS</b> <b>CINTURONES DELANTEROS CON ENROLLADORES</b> <b>CINTURE ANTERIORI A AVVOLGITORI</b>	6132-10	<b>C04 C05</b>	<b>SIEGE AVANT - MATELASSURE</b> <b>VORDERE SITZE - POLSTERUNGEN</b> <b>FRONT SEATS - PADDINGS</b> <b>ASIENTOS DELANTEROS-RELLENOS</b> <b>SEDILI ANTERIORI - IMBOTTITURE</b>	9226-22	<b>D12</b>
<b>CEINTURES DE SECURITE ARRIERE</b> <b>HINTERE SICHERHEITSGURTE</b> <b>REAR SAFETY BELTS</b> <b>CINTURONES SEGURIDAD TRASEROS</b> <b>CINTURE DI SICUREZZA POSTERIORI</b>	6164-20	<b>C06</b>	<b>BANQUETTE ARRIERE - ARMATURE</b> <b>HINTERE SITZBAENKE - ARMATUREN</b> <b>REAR BENCH SEATS - FRAMES</b> <b>BANQUETAS TRASERAS - ARMADURAS</b> <b>PANCHETTE POSTERIORE - ARMATURE</b>	9343-11	<b>D11 D10</b>
<b>ACCESSOIRES DE ROUE CRIC</b> <b>RADZUBEHOER - WAGENHEBER</b> <b>WHEEL ACCESSORIES - JACK</b> <b>ACCESORIOS DE RUEDA - GATO</b> <b>ACCESSORI PER RUOTA - CRICCO</b>	6223.10	<b>C07</b>	<b>BANQUETTE ARRIERE - MATELASSURE</b> <b>HINTERE SITZBAENKE - ARMATUREN</b> <b>REAR BENCH SEATS - FRAMES</b> <b>BANQUETAS TRASERAS - ARMADURAS</b> <b>PANCHETTE POSTERIORE - ARMATURE</b>	9344-12	<b>D09</b>
<b>SIEGES AVANT - GARNITURES</b> <b>VORDERE SITZE - BEZUEGE</b> <b>FRONT SEATS - TRIMMINGS</b> <b>ASIENTOS DEL. - GUARNECIDOS</b> <b>SEDILE ANTERIORI - RIVESTIMENTI</b>	9220-23	<b>C08 C09</b> <b>C10 C11</b>	<b>BANQUETTE ARRIERE - GARNITURES</b> <b>HINTERE SITZBANKE UND BEZUEGE</b> <b>REAR BENCH SEATS AND TRIMMINGS</b> <b>BANQUETA TRASERA Y GUARNECIDOS</b> <b>PANCHETTE POST. E RIVESTIMENTI</b>	9348-13	<b>D08 D07</b>
<b>BANQUETTE AVANT - MATELASSURE</b> <b>VORDERE SITZBANK - POLSTERUNG</b> <b>FRONT BENCH SEAT PADDING</b> <b>BANQUETA DELANTERA - RELLENO</b> <b>SEDILE ANT. A 2 POSTI - IMBOTTITURA</b>	9221-12	<b>C12</b>	<b>CAPOTE</b> <b>ROLLVERDECK</b> <b>HOOD</b> <b>CAPOTA</b> <b>CAPOTE</b> <b>- SPECIALE</b>	9710-10	<b>D06 D05</b> <b>D04</b>

15/02/91 1117	<b>TABLEAU DES VUES</b> AUFSTELLUNG DER BILDER TABLE OF PICTURE B02 ↑ TABLA DE VISTAS TABELLA DELLE VEDUTE	<b>GROUPE</b> GROUP GROUP <b>08</b> GRUPO GRUPPO		
	<b>SOUS-GROUPE</b> UNTERGRUPPE SUBGROUP SUBGRUPO SOTTOGRUPPO		<b>NUMERO</b> NUMMER NUMBER NUMERO NUMERO	<b>VUE</b> BILD PICTURE VISTA VEDUTA
	<b>CAPOTE AVEC PORTIQUE</b> ROLLVERDECK MIT RAHMENSTANGE HOOD WITH FRAME ASSY CAPOTA CON PORTICO CAPOTE CON PORTICO		9713-11	D03 D02 D01 E01
	<b>TAPIS</b> CARPETS - LINING ALFOMBRAS - GUARNECIDOSCR9821 TAPPETI - RIVESTIMENTI CAPOTE CON PORTICO		9732-10	E02
	<b>GARNITURES INTERIEURES</b> INNERE BEZUEGE INNER LINING GUARNECIDOS INTERIORES RIVESTIMENTI INTERNI		9796-10	E03 E04
	<b>PANNEAUX DE PORTE AVANT</b> TUERFUELLUNGEN FRONT DOOR TRIMMING PANELS FRONT PANELES DE PUERTAS DELANTERAS PANNELLI PER PORTIERE ANT.		9828-10	E05 E06 E07
	<b>PANNEAUX DE PORTE ARRIERE</b> HINTERE TUERFUELLUNGEN REAR DOOR PANELS PANELES DE PUERTAS TRASERAS PANNELLI PER PORTIERE POSTERIORI		9829-20	E08 E09 E10

**PARE SOLEIL - RETROVISEUR INTERIEUR**  
 SONNENBLLENDE - INNENRUECKSPIEGEL  
 SUN VISOR - INSIDE REARVIEW MIRROR  
 PARASOL-RETROVISOR INTERIOR  
 PARASOLE-RETROVISORE INTERNO

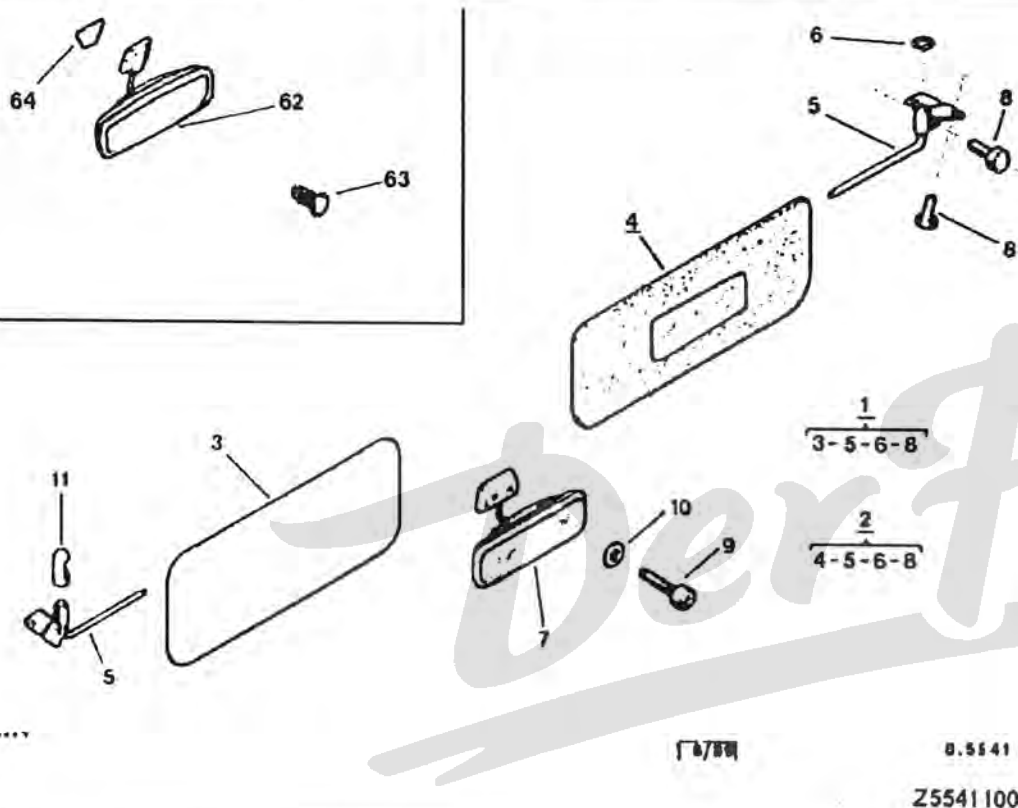

05	AZ 554 2 A	02	AVEC AXE	▶ 1697	SUPPORT CENTRAL MITTELHALTER BRACKET SOPORTE CENTRAL SUPPORTO CENTR
	95 577 197	01	G- AVEC AXE PLASTIQUE	1698 ▶	-
	95 577 198	01	D- AVEC AXE PLASTIQUE	1698 ▶	-
06	ZF 11 087 876	02			SEGMENT D'ARRET HALTEERING STOP RING SEGMENTO RETEN. ANELLO ARRESTO
07	95 495 799	01	JOUR ET NUIT RMP		RETROVISEUR INT INNENR.SPIEGEL INT VIEW MIRROR RETROVISOR INT RETROVISORE INT
08	ZC 9621 151 W	02	TH 5X7,5		VIS TH SCHRAUBE CAPSCREW TORNILLO TH VITE
09	79 03 007 103	02	5X0,80-16		VIS TOLE TCB PLECHSCHRAUBE TAPPING SCREW TORNILLO CHAPA VITE
10	79 03 053 025	02	DIAM 5X10X1 RMP 22312019		RONDELLE PLATE FLACHSCHEIBE PLAIN WASHER ARANDELA PLANA RONDELLA PIATTA

95 574 003	01	G- SANS MIROIR HAPPICH	1698 ▶	PARE-SOLEIL SONNENBLLENDE SUN VISOR PARASOL PARASOLE
95 574 004	01	D- AVEC MIROIR HAPPICH	1698 ▶	-
AZ 554 1 A	01	G- SANS MIROIR	▶ 1697	-
AY 554 1 A	01		▶ 1697	-

51	95 555 858 RP AY5541B DEO AZ5542A (01)	01	G- AVEC MIROIR -CAD	06/80 ▶ 1697	<b>XT</b> PARE-SOLEIL SONNENBLLENDE SUN VISOR PARASOL PARASOLE
	95 574 005	01	G- AVEC MIROIR -CAD	1698 ▶	-
	95 574 007 RP 95574003	01	G- -(D)	1698 ▶	-



15/02/91  
1117 08-5541-10  
PAGE :2  
C03 ↑

**PARE SOLEIL - RETROVISEUR INTERIEUR**  
SONNENBLLENDE - INNENRUECKSPIEGEL  
SUN VISOR - INSIDE REARVIEW MIRROR  
PARASOL-RETROVISOR INTERIOR  
PARASOLE-RETROVISORE INTERNO

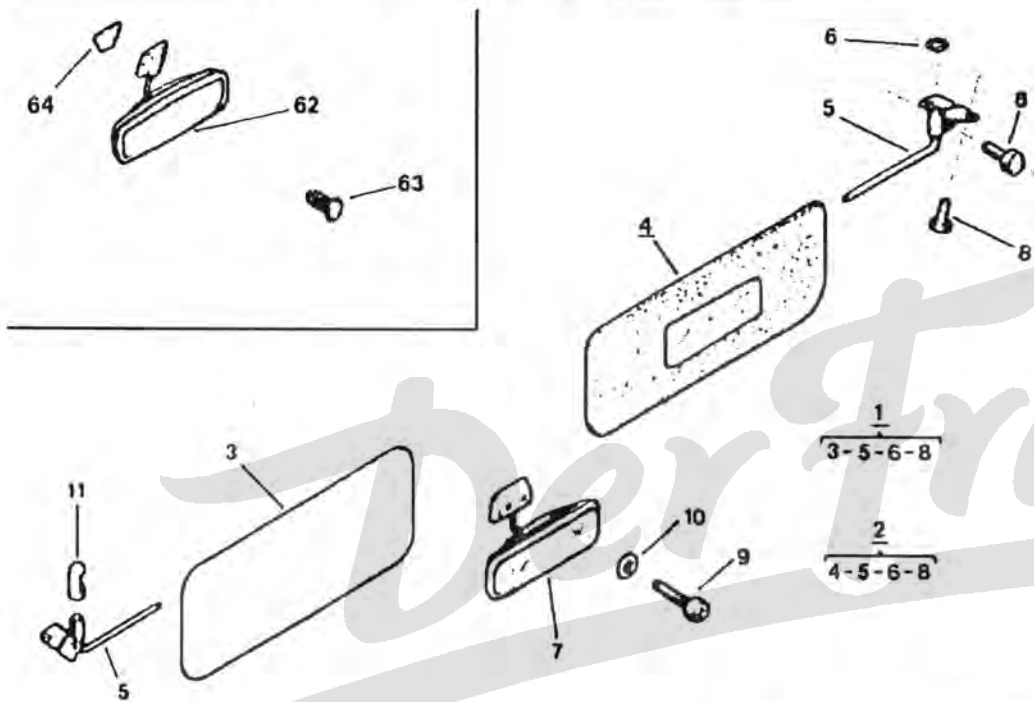

□ 8/88

8.5541 10

25541100

61	AY 554 78	02	PLASTIQUE -(D)	PROTECTEUR SCHUTZ PROTECTOR PROTECTOR PROTEZIONE
62	5 490 745 RP 5490934 DEO 75465856 (01)	01	-(N)	▶ 2061 RETROVISEUR INT INNENR.SPIEGEL INT VIEW MIRROR RETROVISOR INT RETROVISORE INT
63	5 490 934 79 03 077 078	01	-(N) RMP 95495800 , DEO 1-75465856	▶ 2061 -
64	75 407 440	02	-(N)	BOUTON DE FIX KNOPF FIXING KNOB BOTON FIJACION BOTTONE FISSAG
		01	-(N)	CACHE EMBASE FUSSABDECKUNG BASE COVER TAPA BASE TAPPO SEDE
52	95 574 006	01	D- SANS MIROIR -CAD	1698 ▶ PARE-SOLEIL SONNENBLLENDE SUN VISOR PARASOL PARASOLE
	95 574 008 RP 95574004	01	D- -(D)	1698 ▶ -
54	AY 554 1 B	01	G- AVEC MIROIR -CAD	▶ 1697 -

15/02/91  
 1117 08-6132-10  
 PAGE : 1  
 C04 ↑

**CEINTURES DE SECURITE AV A ENROULEUR**  
 VORDERE SICHERHEITSGURTE MIT WICKLERN  
 FRONT SAFETY BELTS WITH WINDERS  
 CINTURONES DELANTEROS CON ENROLLADORES  
 CINTURE ANTERIORI A AVVOLGITORI

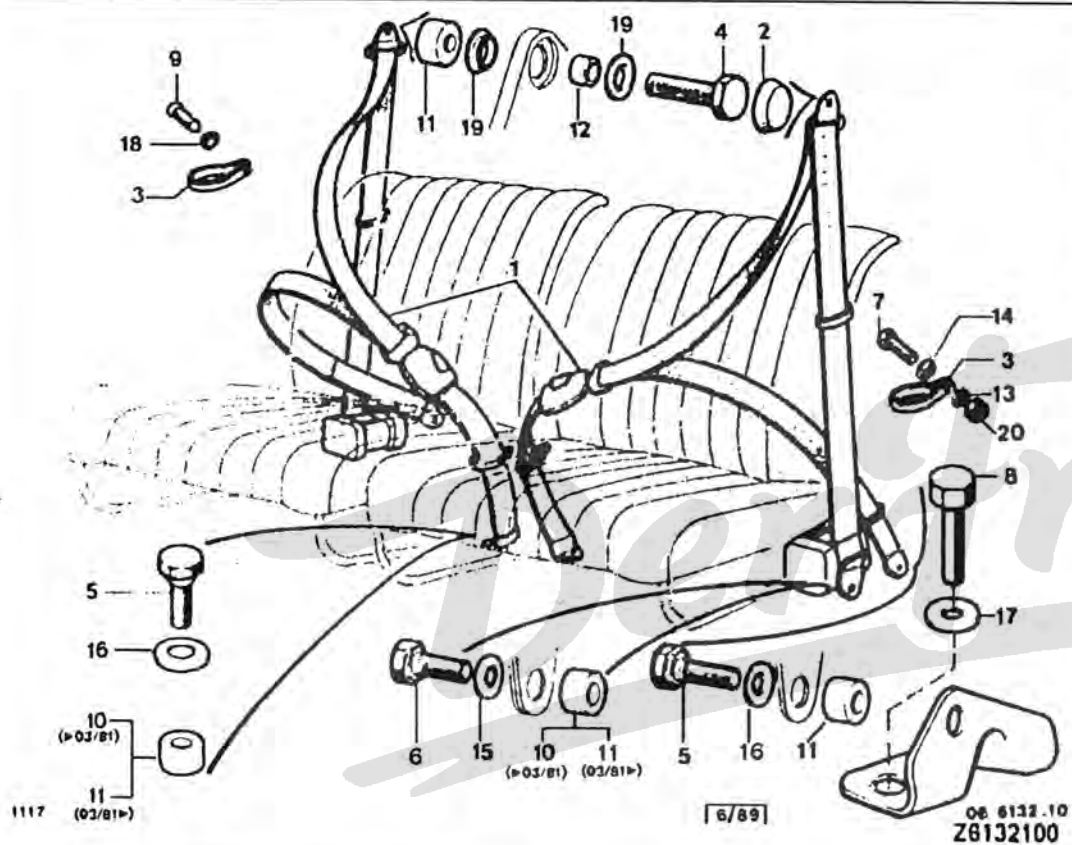

- LES PIECES NON REPAREES SONT N F P

01	95 495 670	01 D- G KLIPPAN RMP	CEINTURE GURT SAFETY BELT CINTURON CINTURA
	95 495 669	01 D- KLIPPAN RMP	

02	79 20 070 298	02	CAPUCHON SCHUTZKAPPE PROTECTOR PLUG CAPUCHON CAPPUCCIO PROT.
03	5 443 999	04	BRIDE MAINTIEN HALTESTEG FLANGE BRIDA SUJECION STAFFA TENUTA
04	75 473 031	02 TH 7/16" LON 25	VIS DE CEINTURE SCHRAUBE S-GURT BELT SCREW TORNILLO VITE CINTURE
05	75 416 368	04 TH 7/16" LON 31	-
06	75 449 950	02 TH DIAM 7/16X20 - 35	-
07	79 03 007 073	04 TCB 5X30	VIS TCB SCHRAUBE CAPSCREW TORNILLO TCB VITE
08	23 826 319	02 9X1,25-28	VIS TH SCHRAUBE CAPSCREW TORNILLO TH VITE
09	79 03 016 140	02 DIAM 3,5 - 16	VIS TOLE TF BLECHSCHRAUBE TAPPING SCREW TORNILLO R CHAP VITE LAMIERA
10	75 407 590	02 20,5X11,3X10	ENTRETOISE ABSTANDSSTUECK SPACER JUEGO DISTANCIA DISTANZIALE
11	75 416 367	06 20,5 X 11,3 X 6	-
12	75 472 683	02 13X11,4X7,2	-
13	79 03 056 005	04 DIAM 5.3X9,4	RONDELLE A DENT ZAHNSCHEIBE SPRING WASHER ARANDELA RONDELLA DENTAT

.../...

15/02/91  
1117 08-6132-10  
PAGE :2  
C05 ↑

**CEINTURES DE SECURITE AV A ENROULEUR**  
VORDERE SICHERHEITSGURTE MIT WICKLERN  
FRONT SAFETY BELTS WITH WINDERS  
CINTURONES DELANTEROS CON ENROLLADORES  
CINTURE ANTERIORI A AVVOLGITORI

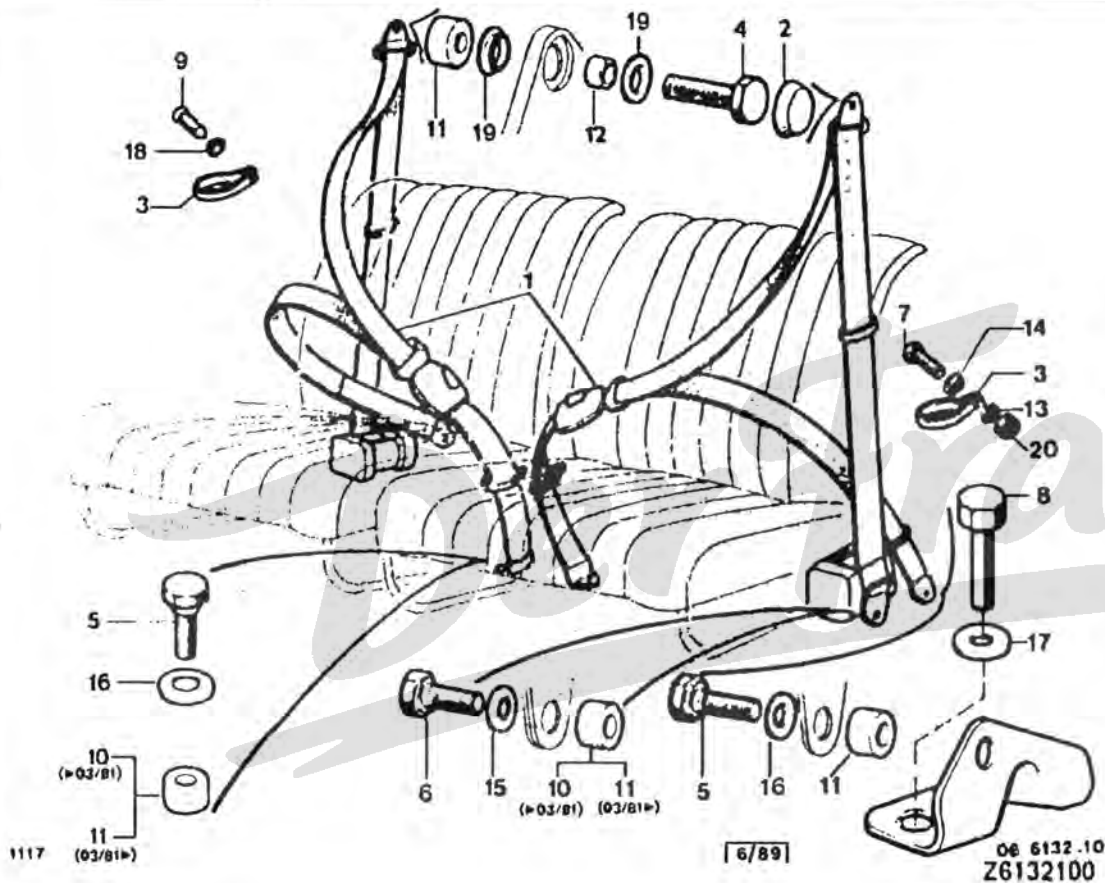

16	79 03 057 047	04	DIAM 13,5 X 22	RONDELLE CUVETT NAPFSCHEIBE CUP WASHER ARANDELA RONDELLA PIATTE
17	79 03 058 031 RP 7903058087	02	9,2X20,25X1,6	RONDELLE CONIQU KONUSSCHEIBE SPRING WASHER ARANDELA RONDELLA CONICA
18	79 03 057 061 RP 26195059	02	DIAM 5	RONDELLE CUVETT NAPFSCHEIBE CUP WASHER ARANDELA RONDELLA PIATTE
19	5 403 022	02		RONDELLE SCHEIBE BELT FIX WASHER ARANDELA RONDELLA
20	79 03 032 006	04	DIAM 5X0,80	ECROU MUTTER NUT TUERCA DADO
51	95 495 657	01	<b>XT</b> D- KLIPPAN -(GB) ▶ 10/80	CEINTURE GURT SAFETY BELT CINTURON CINTURA
14	79 03 058 027	02	DIAM 5X12X1,2	RONDELLE A DENT ZAHNSCHEIBE SPRING WASHER ARANDELA RONDELLA DENTAT
15	26 193 069	02	CR DIAM 4,3X19,6-E 1	RONDELLE SCHEIBE BELT FIX WASHER ARANDELA RONDELLA

**CEINTURES DE SECURITE ARRIERE**  
 HINTERE SICHERHEITSGURTE  
 REAR SAFETY BELTS  
 CINTURONES SEGURIDAD TRASEROS  
 CINTURE DI SICUREZZA POSTERIORI

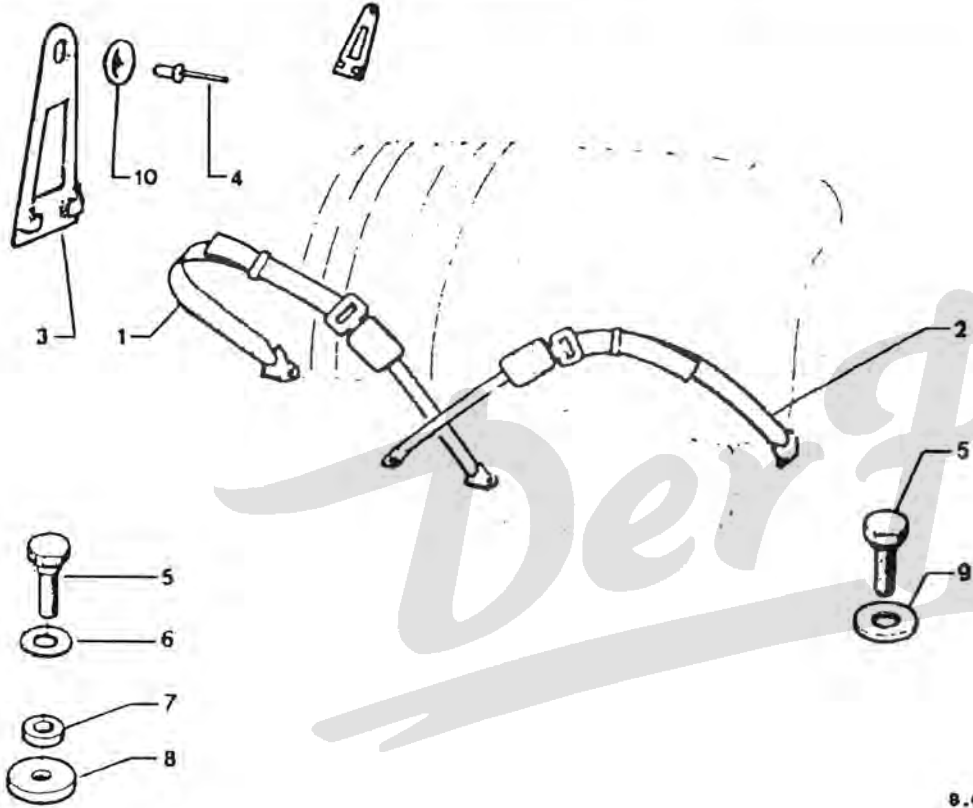

8.616.20  
 Z6164200

01	95 494 692
02	95 494 691
	95 638 067 XX

01	G- KLIPPAN	2062 ▶ 3706
01	G- D- KLIPPAN RMP 5490689	2062 ▶ 3706
02	1 POS - CENT	3706 ▶ -

CEINTURE  
 GURT  
 STATIC BELT  
 CINTURON  
 CINTURA

03	5 467 824	02	▶ 2061	CROCHET HAKEN HOOK GANCHO GANCIO
	95 563 271	02	2062 ▶	-
04	79 03 072 150	02	*POP* DIAM 4	RIVET NIET RIVET REMACHE RIVETTO
05	75 416 368	04	TH 7/16" LON 31	VIS DE CEINTURE SCHRAUBE S-GURT BELT SCREW TORNILLO VITE CINTURE
06	79 03 057 047	02	DIAM 13,5 X 22	RONDELLE CUVETT NAPFSCHIBE CUP WASHER ARANDELA RONDELLA PIATTE
07	77 01 000 955	02	DIAM11,5X21X2	RONDELLE SCHEIBE BELT FIX WASHER ARANDELA RONDELLA
08	79 03 053 121 NFP	02	DIAM 12X32 EP 2,5	RONDELLE PLATE FLACHSCHEIBE PLAIN WASHER ARANDELA PLANA RONDELLA PIATTA
09	22 722 019	02	DIAM 14X27X2,5 RMP 22722009	RONDELLE SCHEIBE BELT FIX WASHER ARANDELA RONDELLA
10	5 469 170	02		-

15/02/91  
 1117 08-6223-10  
 PAGE : 1  
 C07 ↑

**ACCESSOIRES DE ROUE CRIC**  
 RADZUBEHOER - WAGENHEBER  
 WHEEL ACCESSORIES - JACK  
 ACCESORIOS DE RUEDA - GATO  
 ACCESSORI PER RUOTA - CRICCO

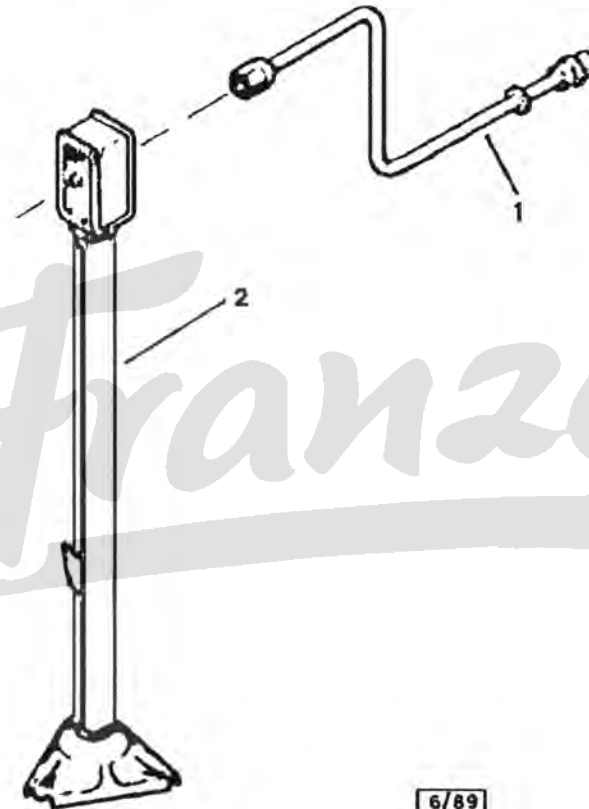

1117

[6/89]

08.6223.10

Z6223100

01	A 251 1 A	01	LON52	VILEBREQUIN KURBEL WHEEL BRACE BERBIQUI ALBERO RUOTA
02	95 494 614	01	ROUSSEAU RMP 5490614	1515 ► CRIC DE LEVAGE WAGENHEBER LIFTING JACK GATO CRICCO DI SOLL.

15/02/91  
 1117 08-9220-23  
 PAGE : 1  
 C08 ↑

**SIEGES AVANT - GARNITURES**  
 VORDERE SITZE - BEZUEGE  
 FRONT SEATS - TRIMMINGS  
 ASIENTOS DEL. - GUARNECIDOS  
 SEDILE ANTERIORI - RIVESTIMENTI

01

75 522 587\*348

01 D-  
 JERSEY A RAYURES + TEP  
 1666 ▶ 2060

GARNITURE  
 BEZUG  
 SEAT LINING  
 GUARNECIDO  
 RIVESTIMENTO

75 522 587\*841

01 D-  
 JERSEY A RAYURES + TEP  
 06/80 ▶ 2060

75 522 587\*846  
 NFP

01 D-  
 JERSEY A RAYURES + TEP  
 1681 ▶ 2060

75 522 587\*900

01 D-  
 JERSEY A RAYURES + TEP  
 06/80 ▶ 2060

95 582 789 AN

01 D-  
 JERSEY A RAYURES + TEP  
 2061 ▶ 2426

95 582 789 AP

01 D-  
 JERSEY A RAYURES + TEP  
 2061 ▶ 2426

95 582 789 LR

01 D-  
 JERSEY A RAYURES + TEP  
 2061 ▶ 2426

95 582 789 PH

01 D-  
 JERSEY A RAYURES + TEP  
 2061 ▶ 2426

75 510 599\*700

01 G-  
 TARGA + TEP ▶ 2060

95 582 738 FXX

01 G-  
 TARGA + TEP  
 RMP 95582738XA 2061 ▶

5 505 283\*700

01 D-  
 TARGA + TEP ▶ 2060

95 582 737 FXX

01 D-  
 TARGA + TEP  
 RMP 95582737XA 2061 ▶

95 612 618 FLV

01 G-  
 TEP JEAN'S 3157 ▶ 3604

95 640 190 LV

01 G-  
 TEP JEAN'S 3605 ▶

REP 1 POUR SIEGE A DOSSIER FIXE REP 2 POUR SIEGE A DOSSIER ARTICLE

1	75 522 585*322	01 G-	▶ 1850	GARNITURE BEZUG SEAT LINING GUARNECIDO RIVESTIMENTO
	75 522 585*348 NFP	01 G-	1666 ▶ 2060	JERSEY A RAYURES + TEP
	75 522 585*841	01 G-	06/80 ▶ 2060	JERSEY A RAYURES + TEP
	75 522 585*846	01 G-	1681 ▶ 2060	JERSEY A RAYURES + TEP
	75 522 585*900	01 G-	06/80 ▶ 2060	JERSEY A RAYURES + TEP
	95 582 790 AN	01 G-	2061 ▶ 2426	JERSEY A RAYURES + TEP
	95 582 790 AP	01 G-	2061 ▶ 2426	JERSEY A RAYURES + TEP
	95 582 790 LR NFP	01 G-	▶ 2426	BLEU A RAYURES VERT ET NOIR
	95 582 790 PH	01 G-	2061 ▶ 2426	JERSEY A RAYURES + TEP
	75 522 587*322	01 D-	▶ 1850	JERSEY A RAYURES + TEP

.../...

15/02/91  
1117 08-9220-23  
PAGE : 2  
C09 ↑

**SIEGES AVANT - GARNITURES**  
VORDERE SITZE - BEZUEGE  
FRONT SEATS - TRIMMINGS  
ASIENTOS DEL. - GUARNECIDOS  
SEDILE ANTERIORI - RIVESTIMENTI

01	95 612 609 FLV	01 D- TEP JEAN'S	3157 ▶ 3604	GARNITURE BEZUG SEAT LINING GUARNECIDO RIVESTIMENTO
	95 640 189 LV	01 D- TEP JEAN'S	3605 ▶	
	95 582 782 FYC	01 G- JERSEY UNI -CHARLESTON RMP 95575738SB	2061 ▶ 4353	
	95 582 782 TL	01 G- JERSEY UNI + TEP -CHARLESTON	4354 ▶ 4565	
	95 582 782 FYC	01 G- JERSEY UNI -CHARLESTON	4566 ▶	
	95 575 739 SB RP 95582781FYC	01 D- JERSEY UNI + TEP -CHARLESTON	▶ 2060	
	95 582 781 FYC	01 D- JERSEY UNI -CHARLESTON	2061 ▶ 4353	
	95 582 781 TL	01 D- JERSEY UNI + TEP -CHARLESTON	4354 ▶ 4565	
	95 582 781 FYC	01 D- JERSEY UNI -CHARLESTON -TOUS TYPES	4566 ▶	
	95 595 271 AS	01 G- JERSEY A RAYURES	2426 ▶ 3096	
	95 595 270 AS	01 D- JERSEY A RAYURES	1983 ▶ 3096	

01

95 612 620 FTM

01 G-  
TISSU CHINOIS + TEP  
3097 ▶ 3604

GARNITURE  
BEZUG  
SEAT LINING  
GUARNECIDO  
RIVESTIMENTO

95 640 187 TM

01 G-  
TISSU CHINOIS + TEP 3605 ▶

95 612 610 FTM

01 D-  
TISSU CHINOIS + TEP  
3097 ▶ 3604

95 640 188 TM

01 D-  
TISSU CHINOIS + TEP 3605 ▶

95 638 540

01 G-  
JERSEY DIAGONAL  
-DOLLY  
RMP 95612620FTD 3372 ▶

95 638 539

01 D-  
JERSEY DIAGONAL  
-DOLLY  
RMP 95612610FTD 3372 ▶

02

75 522 586\*348

01 G-  
JERSEY A RAYURES + TEP  
1666 ▶ 2060

75 522 586\*841

01 G-  
JERSEY A RAYURES + TEP  
06/80 ▶ 2060

75 522 586\*846  
NFP

01 G-  
JERSEY A RAYURES + TEP  
1666 ▶ 2060

5 505 268\*700  
NFP

01 G-  
TARGA + TEP ▶ 2060

95 575 744 SB

01 G-  
JERSEY UNI + TEP ▶ 2060

03

95 595 956 NG

01 G-  
JERSEY A RAYURES  
-FRANCE 3

COIFFE DOSSIER  
LEHNENBEZUG  
SQUAB COVER  
FUNDA RESPALDO  
RIVESTIMENTO

95 595 955 NG

01 D-  
JERSEY A RAYURES  
-FRANCE 3

02/91  
17 08-9220-23  
IGE : 3  
0 ↑

**SIEGES AVANT - GARNITURES**  
VORDERE SITZE - BEZUEGE  
FRONT SEATS - TRIMMINGS  
ASIENTOS DEL. - GUARNECIDOS  
SEDILE ANTERIORI - RIVESTIMENTI

52

95 595 958 NG

01 G.  
JERSEY A RAYURES  
-FRANCE 3

COIFFE COUSSIN  
BEZUG SITZKISS  
CUSHION COVER  
FUNDA COJIN  
FODERA CUSCINO

95 595 957 NG

01 D.  
JERSEY A RAYURES  
-FRANCE 3

95 582 781 TL

01 D.  
JERSEY UNI + TEP  
-CHARLESTON -(D) 4354 ▶ 4579

**GARNITURE  
BEZUG  
SEAT LINING  
GUARNECIDO  
RIVESTIMENTO**

95 583 446 FXX

01 G.  
TARCA  
-(D) 2061 ▶ 3156

95 612 619 FLV

01 G.  
TEP JEAN'S  
-(D) ▶ 3036

95 640 180 LV

01 G.  
TEP JEAN'S  
-(D) 3065 ▶

95 583 125 FYC

01 G.  
JERSEY UNI  
-CHARLESTON -(D) 2061 ▶ 4353

95 583 125 TL

01 G.  
JERSEY UNI + TEP  
-CHARLESTON -(D) 4354 ▶ 4579

95 583 125 FYC

01 G.  
JERSEY UNI  
-CHARLESTON -(D) 4580 ▶

95 595 274 AS

95 612 621 FTM

95 640 179 TM

95 607 755 EC

95 607 755 LH

95 607 756 EC

95 607 756 LH

95 595 270 FYC

96 013 247 DA

96 013 248 DA

95 595 274 FYC

95 599 291 EC

95 599 292 EC

01 G.  
JERSEY A RAYURES  
-(D) 2426 ▶ 3096

01 G.  
TISSU CHINOIS + TEP  
-(D) 3097 ▶ 3604

01 G.  
TISSU CHINOIS + TEP  
-(D) 3605 ▶

01 G.  
JERSEY COTELE  
-(D) 2670 ▶

01 G.  
JERSEY COTELE  
-(D) 2670 ▶  
RMP 95607755LD

01 D.  
JERSEY COTELE  
-(D) 2670 ▶

01 D.  
JERSEY COTELE  
-(D) 2670 ▶  
RMP 95607756LD

01 D.  
JERSEY CHEVRONS  
-(D) 3066 ▶

01 D.  
JERSEY CHEVRONS  
-(D) 3461 ▶

01 G.  
JERSEY CHEVRONS  
-(D) 3461 ▶

01 G.  
JERSEY CHEVRONS  
-(D) 3066 ▶

01 D.  
JERSEY CHEVRONS  
-(D) 2670 ▶

01 G.  
JERSEY CHEVRONS  
-(D) 2670 ▶

**GARNITURE  
BEZUG  
SEAT LINING  
GUARNECIDO  
RIVESTIMENTO**

.../...



15/02/91 1117 08-9220-23 PAGE : 4 C11 ↑		SIEGES AVANT - GARNITURES VORDERE SITZE - BEZUEGE FRONT SEATS - TRIMMINGS ASIENTOS DEL. - GUARNECIDOS SEDILE ANTERIORI - RIVESTIMENTI		53	95 583 096 FXX	01 D- TARGA -CAD FIXE	2061 ▶ 3156	COIFFE DOSSIER LEHNENBEZUG SQUAB COVER FUNDA RESPALDO RIVESTIMENTO
					95 612 628 FLV NFP	01 G- TEP JEAN'S -CAD FIXE	3157 ▶ 3604	
					95 640 168 LV	01 G- TEP JEAN'S -CAD FIXE	3605 ▶	
					95 612 615 FLV NFP	01 D- TEP JEAN'S -CAD FIXE	3157 ▶ 3604	
					95 640 167 LV	01 D- TEP JEAN'S -CAD FIXE	3605 ▶	
				54	5 505 320*700 NFP	01 D- TARGA + TEP -SPECIALE -(D)		COIFFE COUSSIN BEZUG SITZKISS CUSHION COVER FUNDA COJIN FODERA CUSCINO
52	95 634 904 FDA	01 G- JERSEY CHINE -(D) < < ECOLO > >	3249 ▶					GARNITURE BEZUG SEAT LINING GUARNECIDO RIVESTIMENTO
	95 634 903 FDA	01 D- JERSEY CHINE -(D) < < ECOLO > >	3249 ▶					
	96 026 444 YC	01 G- TISSU CHEVRON -DOLLY -(CH)	3857 ▶					
	96 026 443 YC	01 D- TISSU CHEVRON -DOLLY -(CH)	3857 ▶					
	95 634 904 FDA	01 G- JERSEY CHINE -VERTE -(CH)	3822 ▶					
	95 634 903 FDA	01 D- JERSEY CHINE -VERTE -(CH)	3822 ▶					
53	5 505 310*700	01 G- TARGA + TEP -SPECIALE -(D) ARTICULE	▶ 1665					COIFFE DOSSIER LEHNENBEZUG SQUAB COVER FUNDA RESPALDO RIVESTIMENTO
	5 505 317*700 NFP	01 D- TARGA + TEP -SPECIALE -(D) FIXE						
	95 595 959 NG NFP	01 G- JERSEY A RAYURES -FRANCE 3 -(D)						
	95 583 097 FXX NFP	01 G- TARGA -CAD FIXE	2061 ▶ 3156					
					95 595 960 NG	01 G- JERSEY A RAYURES -FRANCE 3 -(D)		
					95 612 634 FLV	02 TEP JEAN'S -CAD	3157 ▶ 3604	
					95 640 166 LV	02 TEP JEAN'S -CAD	3605 ▶	

15/02/91  
 1117 08-9221-12  
 PAGE : 1  
 C12 ↑

**BANQUETTE AVANT - MATELASSURE**  
 VORDERE SITZBANK - POLSTERUNG  
 FRONT BENCH SEAT - PADDING  
 BANQUETA DELANTERA - RELLENO  
 SEDILE ANT. A 2 POSTI - IMBOTTITURA

03  
 04

5 472 204  
 5 472 205

01  
 01

MATELASSURE  
 POLSTERUNG  
 PADDING  
 ACOLCHADO  
 IMBOTTITURA  
 -

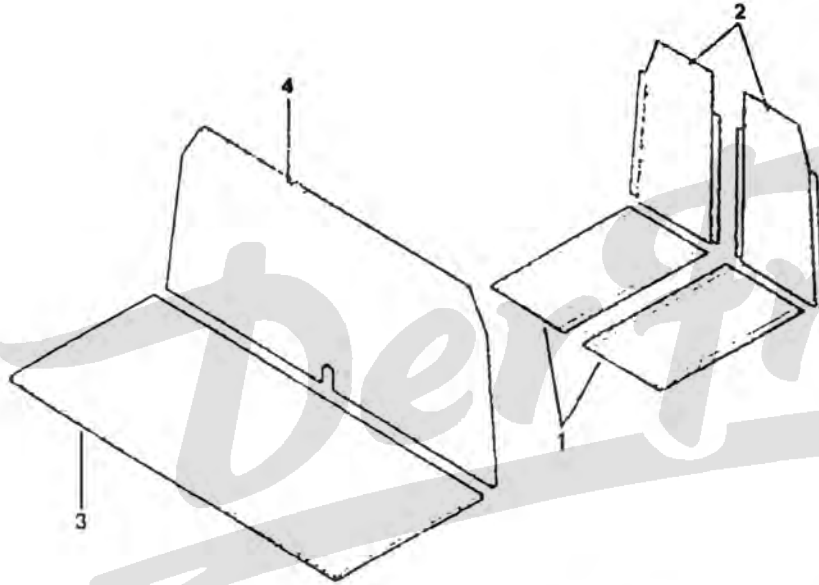

1114

09/83

8.912.12  
 Z9221120

01	5 472 193	01 G-	MATELASSURE POLSTERUNG PADDING ACOLCHADO IMBOTTITURA
	5 472 194	01 D-	-
02	5 472 201	01 G-	-
	5 472 202	01 D-	-

15/02/91  
 1117 08-9222-13  
 PAGE : 1  
 C13 ↑

**BANQUETTE AVANT - GARNITURE**  
 VORDERE SITZBANK - BEZUG  
 FRONT BENCH SEAT - TRIMMING  
 BANQUETA DELANTERA - GUARNECIDO  
 SEDILE ANT. A 2 POSTI - RIVESTIMENTO

- REP 1-GARNITURE COMPLETE  
 REP 2-GARNITURE DE COUSSIN  
 REP 3-GARNITURE DE DOSSIER

01	5 500 536*700	01	TARGA + TEP	GARNITURE BEZUG BENCH LINING GUARNECIDO RIVESTIMENTO
02	95 476 314 FXX	01	TARGA + TEP -SPECIALE	-
	95 612 633 FLV	01	TEP JEAN'S -SPECIALE	-
	95 640 164 LV	01	TEP JEAN'S -SPECIALE	3157 ▶ 3604 3605 ▶ COIFFE COUSSIN BEZUG SITZKISS. CUSHION COVER FUNDA COJIN FODERA CUSCINO
03	95 476 310 FXX	01	TARGA + TEP -SPECIALE	GARNITURE BEZUG BENCH LINING GUARNECIDO RIVESTIMENTO
	95 612 635 FLV	01	TEP JEAN'S -SPECIALE	-
	95 640 163 LV	01	TEP JEAN'S -SPECIALE	3157 ▶ 3604 3605 ▶ COIFFE DOSSIER BEZUG R-LEHNE SOUAB COVER FUNDA RESPALDO FODERA SCHIENAL

15/02/91  
1117 08-9225-11  
PAGE : 1  
C14 ↑

**BANQUETTE AVANT-ARMATURE**  
VORDERE SITZE - ARMATUREN  
FRONT SEATS - FRAMES  
ASIENTOS DELANTEROS-ARMADURAS  
SEDILI ANTERIORI - ARMATURE

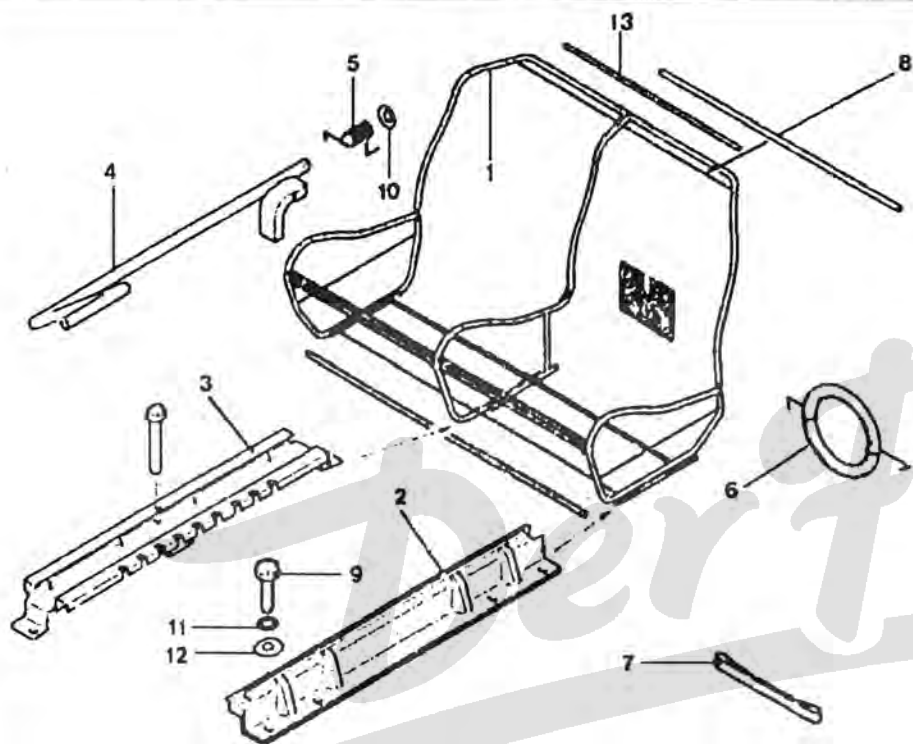

1117

06/89

08.9225 11  
Z9225110

- LES PIECES NON REPEREES SONT NFP

01	5 472 190	01	ARMATURE ARMATUR BENCH FRAME ARMADURA BANQUE ARMATURA
02	96 995 253	02	LAT RMP AM922637A  SUPPORT SIEGE HALTER SEAT BRACKET SOPORTE ASIENTO SUPPORTO

03	96 995 254	01	CENT SUPPORT SITZBANKHALTER BENCH BRACKET SOPORTE SOPPORTO
04	AM 922 12 B	01	G- LEVIER HEBEL UNLOCKING LEVER PALANCA LEVA
05	AM 922 271 B	01	G- RESSORT FEDER LEVER SPRING RESORTE MOLLA
06	A 922 114	99	CAOUTCHOUC ANHEAU+ CROCHET RING HOOK + RING ANILLO ANELLO + GANCIO
07	5 413 322	04	TENDEUR SPAN VORRICHT TENSIONER TENSOR ANELLO + GANCIO
08	AM 922 104 E	04	LON 1113 TRINGLE GESTAENGE COVER LINK ROD VARILLA ASTA
09	79 03 101 771	06	DIAM7X100-20 RMP 23719319 VIS TH SCHRAUBE CAPSCREW TORNILLO TH VITE
10	26 195 699	02	DIAM6X11X1,05 RMP 26240269 RONDELLE SCHEIBE WASHER ARANDELA RONDELLA
11	79 03 056 012	06	CR 7,3X12 RÖNDELLE GROWER GROWERSCHEIBE SPRING WASHER ARANDELA RONDELLA GROWER

.../...

15/02/91  
 1117 08-9225-11  
 PAGE : 2  
 C15 →

**BANQUETTE AVANT-ARMATURE**  
**VORDERE SITZE - ARMATUREN**  
**FRONT SEATS - FRAMES**  
**ASIENTOS DELANTEROS-ARMADURAS**  
**SEDILI ANTERIORI - ARMATURE**

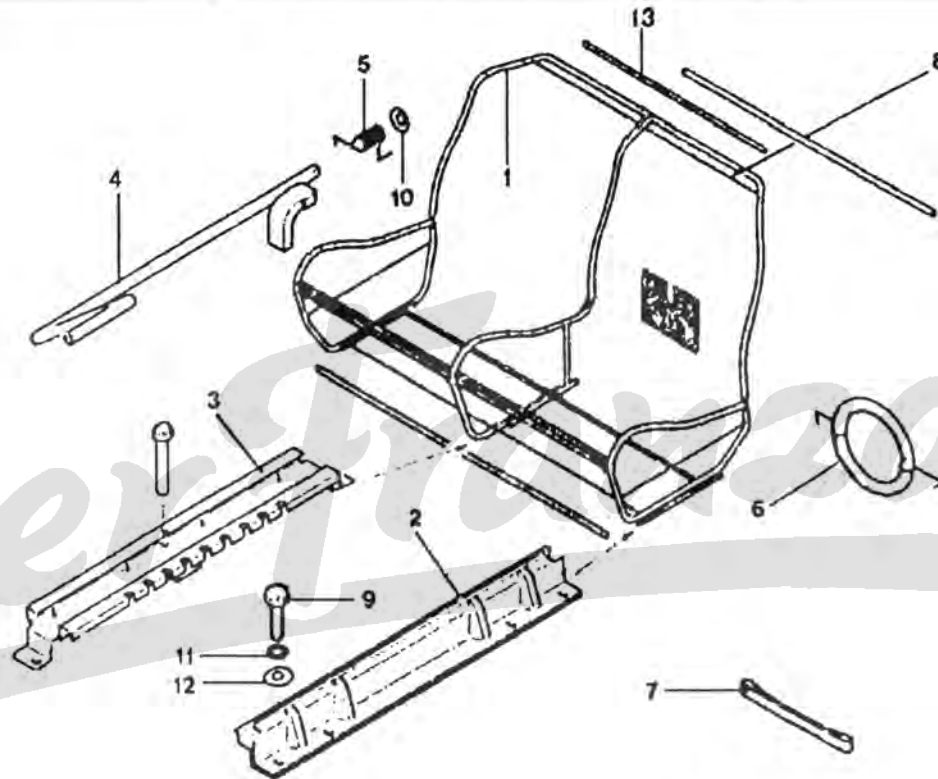

1117

06/89

08.9225 11  
 Z9225110

12	79 03 058 029	08	DIAM 7.2 X14,2X1,4 RMP ZC981917IU	RONDELLE CONIQU KONUSSCHEIBE SPRING WASHER ARANDELA RONDELLA CONICA
13	75 514 338	01	SUP-LON 880	TRINGLE GESTAENGE COVER LINK ROD VARILLA ASTA

15/02/91  
 1117 08-9225-21  
 PAGE : 1  
 D15 ↓

**SIEGE AVANT - ARMATURE**  
**VORDERE SITZE - ARMATUREN**  
**FRONT SEATS - FRAMES**  
**ASIENTOS DELANTEROS-ARMADURAS**  
**SEDILI ANTERIORI - ARMATURE**

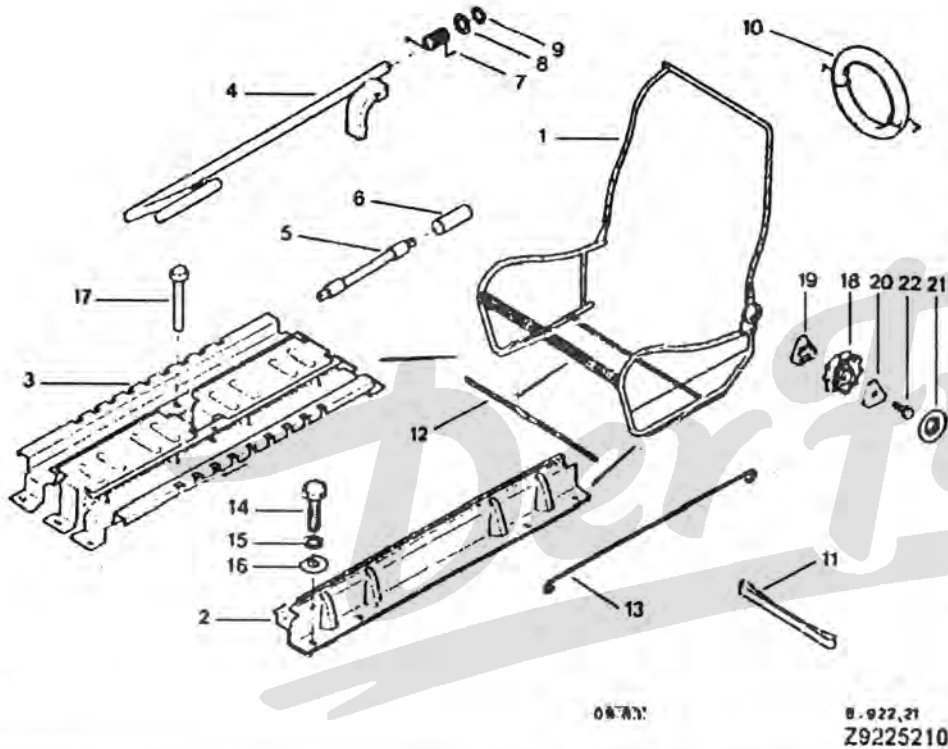

1114

08-922

8-922,21  
 Z9225210

01	5 505 253	01 G-ARTICULE	▶ 1883	ARMATURE SIEGE GESTELL SEAT FRAME ARMADURA ASIEN. ARMATURA SEDILE
	95 582 743	01 G-ARTICULE	1884 ▶	-
	75 511 626	01 G-FIXE	▶ 1883	-
	75 511 627	01 D-FIXE	▶ 1883	-

01	95 582 742	01 G-FIXE RMP95582740	1884 ▶	ARMATURE SIEGE GESTELL SEAT FRAME ARMADURA ASIEN ARMATURA SEDILE
	95 582 741	01 D-FIXE RMP95582739	1884 ▶	-
02	96 995 253	02 LAT RMP AM922637A		SUPPORT SIEGE HALTER SEAT BRACKET SOPORTE ASIENTO SUPPORTO
03	5 484 807	01 CENT RMP AM912278A		-
04	AM 922 12 B	01 G-		LEVIER HEBEL UNLOCKING LEVER PALANCA LEVA
	AM 912 4	01 D-		-
05	5 505 255	01 G- AV-LON 513		CABLE DE CDE VERSTELLZUG CONTROL CABLE CABLE MANDO CAVO DI COMANDO
06	5 486 647	02		GAINÉ DE CABLE ZUGSCHUTZHUELLE CONTROL SHEATH FUNDA DE CABLE GUAINA DEL CAVO
07	AM 922 271 B	01 G-		RESSORT FEDER LEVER SPRING RESORTE MOLLA
	AM 912 111	01 D-		-
08	22 363 019	04 DIAM 6X14X1,5		RONDELLE SCHEIBE PISTON WASHER ARANDELA RONDELLA
09	26 195 699	41 DIAM6X11X1.05 RMP 26240269		-

.../...

15/02/91  
 1117 08-9225-21  
 PAGE : 2  
 D14 ↓

**SIEGE AVANT - ARMATURE**  
 VORDERE SITZE - ARMATUREN  
 FRONT SEATS - FRAMES  
 ASIENTOS DELANTEROS-ARMADURAS  
 SEDILI ANTERIORI - ARMATURE

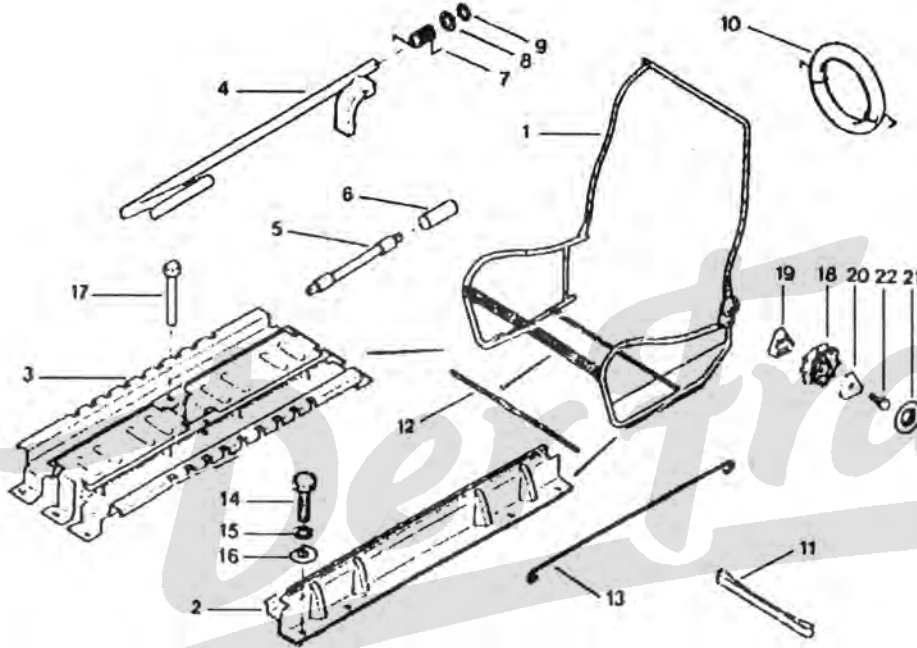

1114

08771

8-922,21  
 Z9225210

10	A 922 114	99	CAOUTCHOUC	ANNEAU+ CROCHET RING HOOK + RING ANILLO ANELLO + GANCIO
11	5 413 322	04		TENDEUR SPAN VORRICHT TENSIONER TENSOR ANELLO + GANCIO

12	AMB 912 100 A	06	LON 513	TRINGLE GESTAENGE COVER LINK ROD VARILLA ASTA
13	AM 922 109 C	02	LON 500	-
14	79 03 101 771	06	DIAM7X100-20 RMP.23719319	VIS TH SCHRAUBE CAPSCREW TORNILLO TH VITE
15	79 03 056 012	06	CR 7,3X12	RONDELLE GROWER GROWERSCHEIBE SPRING WASHER ARANDELA RONDELLA GROWER
16	79 03 058 029	06	DIAM 7,2 X14,2X1,4 RMP ZC9619171U	RONDELLE CONIQU KONUSSCHEIBE SPRING WASHER ARANDELA RONDELLA CONICA
17	26 120 279	02		AXE ACHSE SHAFT EJE PERNO
18	5 486 019	01		BOUTON KNOPF LEVER BUTTON BOTON PALANCA BOTTONE
19	5 486 015	01	IMT	PLAQUETTE ARRET ANHALTEPLAETTCH STOP PLATE PLAQUETA PIASTRA ARRESTO
20	5 486 016	01	EXT	-
21	5 486 018	01		BOUTON KNOPF LEVER BUTTON BOTON PALANCA BOTTONE
22	5 486 017	01		VIS SCHRAUBE HINGE SCREW TORNILLO VITE

.../...

15/02/91  
1117 08-9225-21  
PAGE : 3  
D13 ↓

**SIEGE AVANT - ARMATURE**  
VORDERE SITZE - ARMATUREN  
FRONT SEATS - FRAMES  
ASIENTOS DELANTEROS-ARMADURAS  
SEDILI ANTERIORI - ARMATURE

54

5 484 809

01 G-  
-(D)

**LEVIER DE CDE**  
HEBEL  
CONTROL LEVER  
PALANCA MANDO  
LEVA

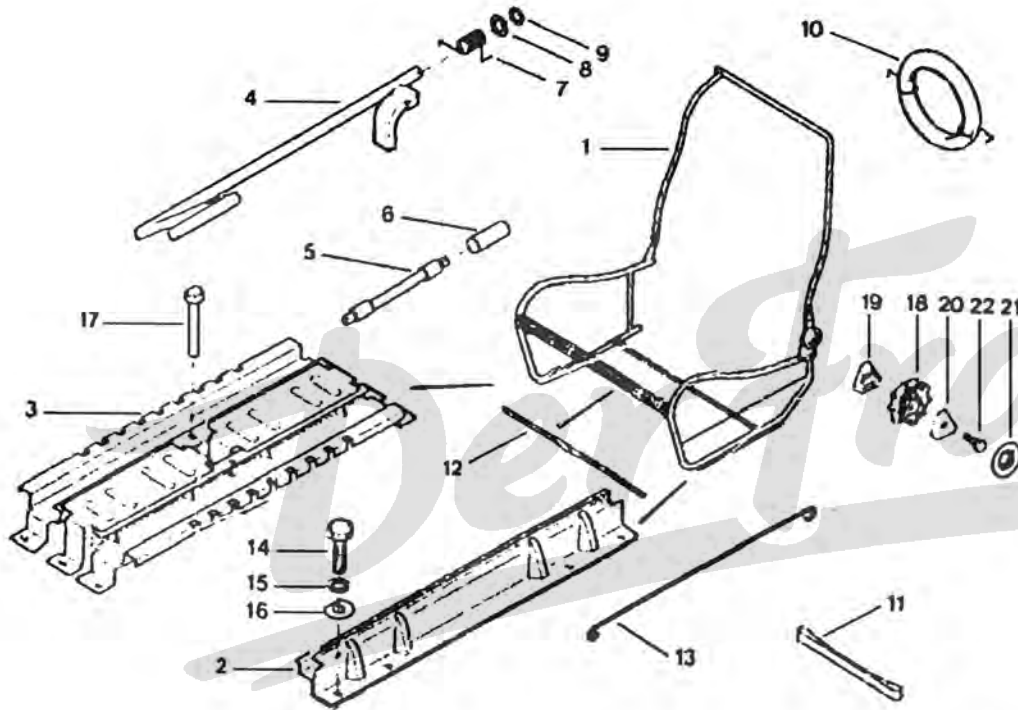

1114

08783

8-922,21  
Z9225210

51

5 505 276

01 D-  
-(D) -(GB)

**XT**

▶ 1883

**ARMATURE SIEGE**  
GESTELL  
SEAT FRAME  
ARMADURA ASIEN.  
ARMATURA SEDILE



15/02/91  
 1117 08-9226-22  
 PAGE : 1  
 D12 ↓

**SIEGE AVANT - MATELASSURE**  
 VORDERE SITZE - POLSTERUNGEN  
 FRONTS SEATS - PADDINGS  
 ASIENTOS DELANTEROS-RELLENOS  
 SEDILI ANTERIORI - IMBOTTITURE

04	95 582 791	02	2061 ▶	MATELASSURE POLSTERUNG CUSHION PADDING ACOLCHADO IMBOTTITURA
----	------------	----	--------	--

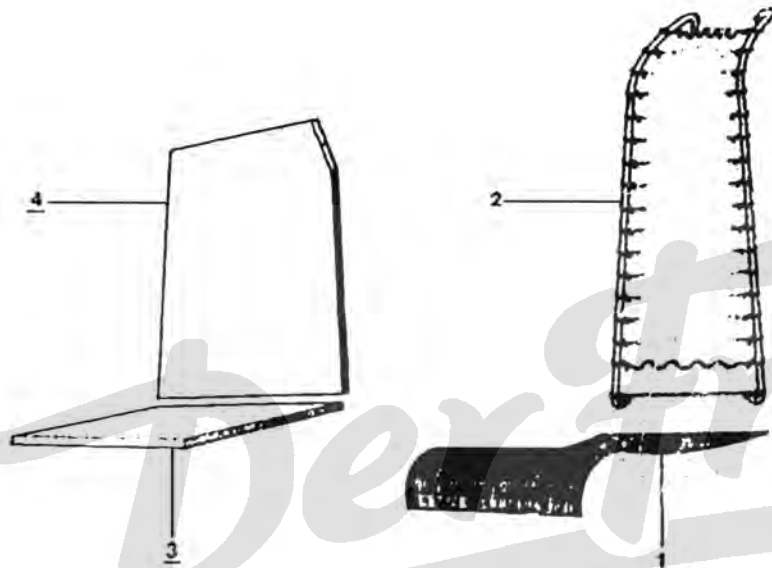

1117

06/89

08 9226.22

Z9226220

			<b>XT</b>	
53	5 472 648	01 G- -(D)		MATELASSURE POLSTERUNG CUSHION PADDING ACOLCHADO IMBOTTITURA
	5 472 106	01 D- -(D)		-
54	95 583 384	01 G- -(D)	2061 ▶	-
	5 472 107	01 D- -(D)		-

01	5 472 098	02	MATELASSURE POLSTERUNG CUSHION PADDING ACOLCHADO IMBOTTITURA
02	75 527 461	01 G-	-
	75 528 608	01 D-	-
03	AY 912 94	02	-
04	AY 912 117	02	▶ 2062

**BANQUETTE ARRIERE - ARMATURE**  
HINTERE SITZBAENKE - ARMATUREN  
REAR BENCH SEATS - FRAMES  
BANQUETAS TRASERAS - ARMADURAS  
PANCHETTE POSTERIORE - ARMATURE

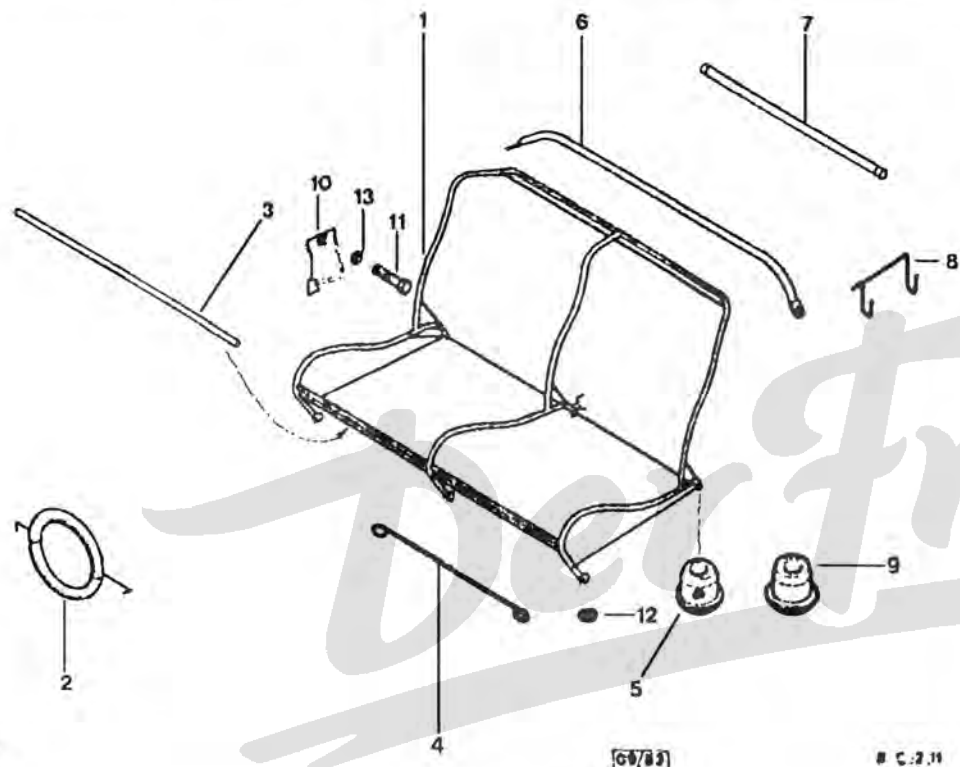

1114

[66/83]

B.C.2.11

Z9343110

01	75 517 125	01		ARMATURE GESTELL BENCH FRAME ARMADURA ARMATURA
02	A 922 114	99	CAOUTCHOUC	ANNEAU + CROCHET RING HOOK + RING ANILLO ANELLO + GANCIO

03	AM 922 104 E	04	LON 1113	TRINGLE GESTAENGE COVER LINK ROD VARILLA ASTA
04	AM 922 109 C	02	LON 500	-
05	A 922 102	03	CAOUTCHOUC	EMBOUT ENDSTUECK SOCKET TOOL TERMINAL TERMINALE
06	AZ 651 126 A	01	AV - L: 990	SUPPORT HALTER BRACKET SOPORTE SUPPORTO
07	AZ 651 47	01	AR - L: 920	-
08	95 596 355	01	2426 ▶	-
08	AZ 651 110	01	▶ 2427	CROCHET HAKEN HOOK GANCHO GANCIO
09	75 517 500	03	DIAM 26X16-H 21,5	EMBOUT ENDSTUECK SOCKET TOOL TERMINAL TERMINALE
10	5 500 757	01	G-	VERROU DOSSIER RIEGEL SEATBACK LOCK CERROJO CHIAVISTELLO
11	5 500 758	01	D-	-
11	79 03 201 139	04	DIAM 6X1.00-16 RMP 7903001889	VIS TH SCHRAUBE CAPSCREW TORNILLO TH VITE
12	79 03 061 999	03	15X8X3	RONDELLE PLATE FLACHSCHEIBE PLAIN WASHER ARANDELA FLANA RONDELLA PIATTA

.../...

15/02/91  
1117 08-9343-11  
PAGE : 2  
D10 ↓

**BANQUETTE ARRIERE - ARMATURE**  
HINTERE SITZBAENKE - ARMATUREN  
REAR BENCH SEATS - FRAMES  
BANQUETAS TRASERAS - ARMADURAS  
PANCHETTE POSTERIORE - ARMATURE

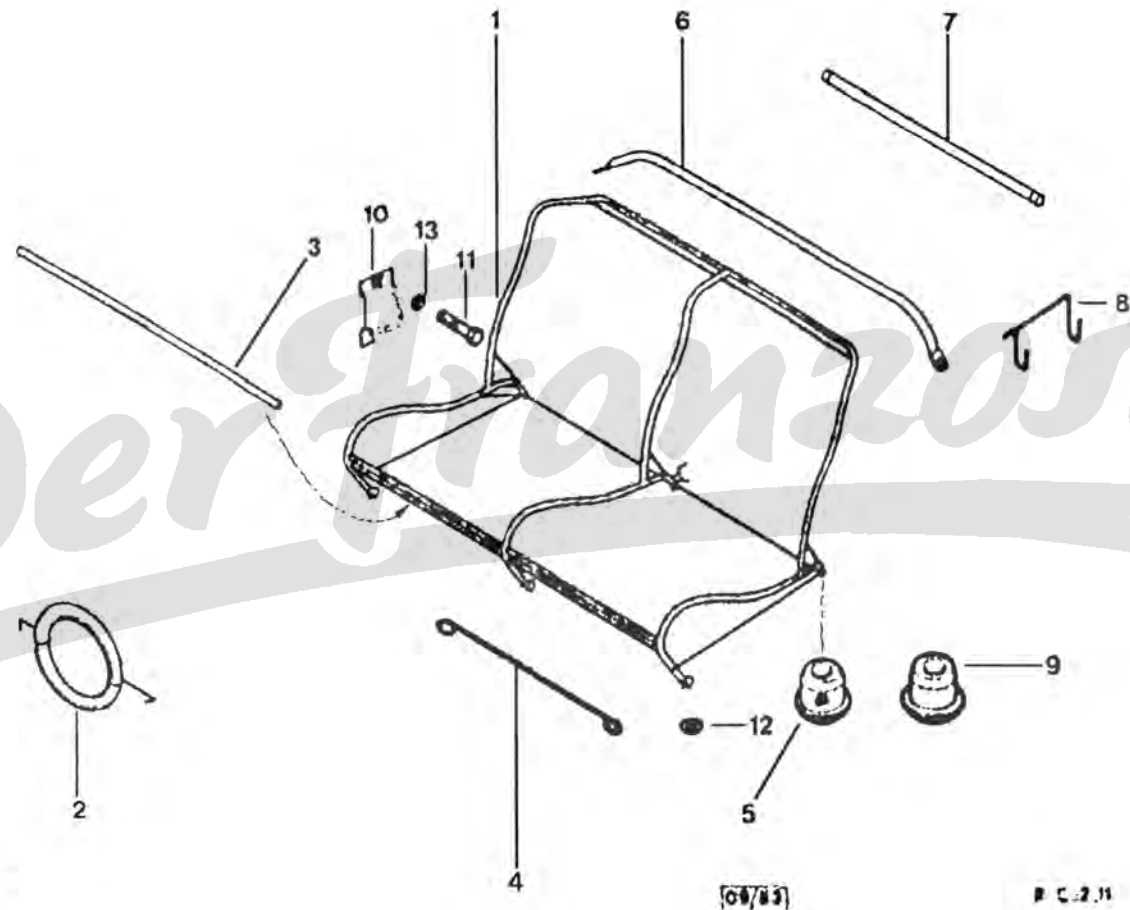

1114

(08/83)

R C-2.11

Z9343110

13 79 03 058 028

04 DIAM 6X14X1,4

RONDELLE A DENT  
ZAHNSCHEIBE  
SPRING WASHER  
ARANDELA  
RONDELLA DENTAT

15/02/91  
 1117 08-9344-12  
 PAGE : 1  
 D09 ↓

**BANQUETTE ARRIERE - MATELASSURE**  
 HINTERE SITZBAENKE - ARMATUREN  
 REAR BENCH SEATS - FRAMES  
 BANQUETAS TRASERAS - ARMADURAS  
 PANCHETTE POSTERIORE - ARMATURE

03

5 410 853

01

MATELASSURE  
 POLSTERUNG  
 CUSHION PADDING  
 ACOLCHADO  
 IMBOTTITURA

04

AY 922 246 C

01

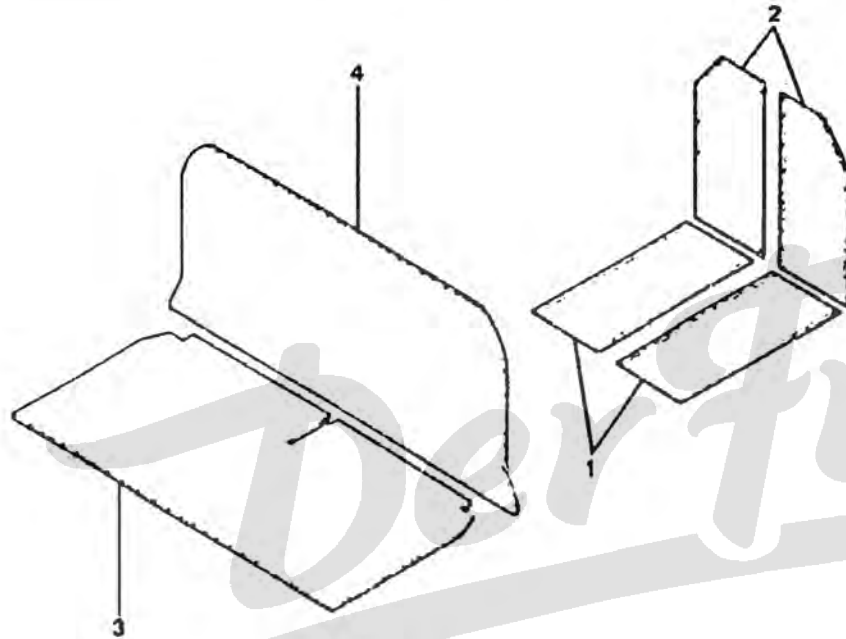

1114

08/83

8.932.02

Z9344120

01 AY 922 60 D

02

SOMMIER  
 FEDERMATRATZE  
 SEAT BTMSPRNGS  
 COLCHON  
 MOLLE SEDILE

02 75 527 462

01 G-

75 528 609

01 D-

15/02/91 1117 08-9348-13 PAGE : 1 D08 ↓		<b>BANQUETTE ARRIERE - GARNITURES</b> HINTERE SITZBANKE UND BEZUEGE REAR BENCH SEATS AND TRIMMINGS BANQUETA TRASERA Y GUARNECIDOS PANCHETTE POST. E RIVESTIMENTI		01	95 500 736 FXX	01 TARGA + TEP	▶ 3156	GARNITURE BEZUG BENCH LINING GUARNECIDO RIVESTIMENTO
					95 612 641 FLV	01 TEP JEAN'S	▶ 3604	-
					95 640 173 LV	01 TEP JEAN'S	3605 ▶	-
01	75 522 588*322 NFP	01	JERSEY A RAYURES ▶ 1665	GARNITURE BEZUG BENCH LINING GUARNECIDO RIVESTIMENTO	02	95 595 962 NG	01 TOILE A RAYURES -FRANCE 3	COIFFE DOSSIER BEZUG R-LEHNE SQUAB COVER FUNDA RESPALDO FODERA SCHIENAL
	75 522 588*348	01	JERSEY A RAYURES 1666 ▶ 2060	-		95 501 270 FXX	01 TARGA + TEP -SPECIALE ▶ 3156	-
	75 522 588*836	01	JERSEY A RAYURES ▶ 06/80	-		95 612 646 FLV	01 TEP JEAN'S -SPECIALE 3157 ▶ 3604	-
	75 522 588*841 NFP	01	JERSEY A RAYURES 06/80 ▶ 2060	-		95 640 169 LV	01 TEP JEAN'S 3605 ▶	-
	75 522 588*846	01	JERSEY A RAYURES 1666 ▶ 2060	-	03	95 595 961 NG	01 TOILE A RAYURES -FRANCE 3	COIFFE COUSSIN BEZUG SITZKISS. CUSHION COVER FUNDA COJIN FODERA CUSCINO
	95 584 339 AM NFP	01	JERSEY A RAYURES + TEP 2061 ▶ 2425	-		95 501 269 FXX	01 TARGA + TEP -SPECIALE ▶ 3156	-
	95 584 339 AP	01	JERSEY A RAYURES + TEP 2061 ▶ 2425	-		95 612 643 FLV	01 TEP JEAN'S -SPECIALE 3157 ▶ 3604	-
	95 584 339 LR NFP	01	JERSEY A RAYURES + TEP 2061 ▶ 2425	-		95 640 170 LV	01 TEP JEAN'S 3605 ▶	-
	95 595 300 AS	01	TOILE A RAYURES 2426 ▶	-	04	95 593 807 NG	01 TEP GRAIN CUIR LIEGE -FRANCE 3	PORTE-BAGAGES GEPAECKTRAEGER LUGGAGE CARRIER PORTAEQUIPAJES PORTAPACCO
	95 612 642 FTM	01	TISSU CHINOIS 3097 ▶ 3604	-		95 599 288	01 ENS"PAM" MOQUETTE	-
	95 640 174 TM	01	TISSU CHINOIS 3605 ▶	-		AZ 651 236 A	01	-
	95 638 541	01	JERSEY DIAGONAL -DOLLY RMP 95612642FTD 3372 ▶	-		AZ 651 126 A	01 AV - L: 990	SUPPORT HALTER BRACKET SOPORTE SUPPORTO
	95 575 751 FYC	01	JERSEY UNI -CHARLESTON 2061 ▶ 4353 RMP 95575751SB	-	05	AZ 651 47	01 AR - L: 920	-
	95 575 751 TL	01	JERSEY UNI + TEP -CHARLESTON 4354 ▶ 4565	-				+ .../...
	95 575 751 FYC	01	JERSEY UNI -CHARLESTON 4566 ▶	-				

15/02/91  
 1117 08-9348-13  
 PAGE : 2  
 D07 ↓

**BANQUETTE ARRIERE - GARNITURES**  
 HINTERE SITZBANKE UND BEZUEGE  
 REAR BENCH SEATS AND TRIMMINGS  
 BANQUETA TRASERA Y GUARNECIDOS  
 PANCHETTE POST. E RIVESTIMENTI

51

95 634 902 FDA

01

JERSEY CHINE  
 -(CH)

3622 ▶

GARNITURE  
 BEZUG  
 BENCH LINING  
 GUARNECIDO  
 RIVESTIMENTO

06

AZ 651 110

01

CROCHET  
 HAKEN  
 HOOK  
 GANCHO  
 GANCIO

51

**XT**

95 607 754 EC

01

JERSEY COTELE  
 -(D)

2870 ▶

GARNITURE  
 BEZUG  
 BENCH LINING  
 GUARNECIDO  
 RIVESTIMENTO

95 607 754 LH

01

JERSEY COTELE  
 -(D)  
 RMP 95607754LD

2870 ▶

95 595 300 FYC

01

JERSEY CHEVRONS  
 -(D)

3088 ▶

96 013 249 DA

01

JERSEY CHEVRONS  
 -(D)

3645 ▶

95 599 293 EC

01

JERSEY CHEVRONS  
 -(D)

2670 ▶

95 634 902 FDA

01

JERSEY CHINE  
 -(D)  
 \* ECOLO \*

3249 ▶

96 026 446 YC

01

TISSU CHEVRON  
 -DOLLY -(D)

3857 ▶

95 575 751 FYC

01

JERSEY UNI  
 -CHARLESTON -(D)

2061 ▶ 4353

95 575 751 TL

01

JERSEY UNI + TEP  
 -CHARLESTON -(D)

4354 ▶ 4579

95 575 751 FYC

01

JERSEY UNI  
 -CHARLESTON -(D)

4580 ▶



15/02/91  
 1117 08-9710-10  
 PAGE : 1  
 D06 ↓

**CAPOTE**  
 ROLLVERDECK  
 HOOD  
 CAPOTA  
 CAPOTE

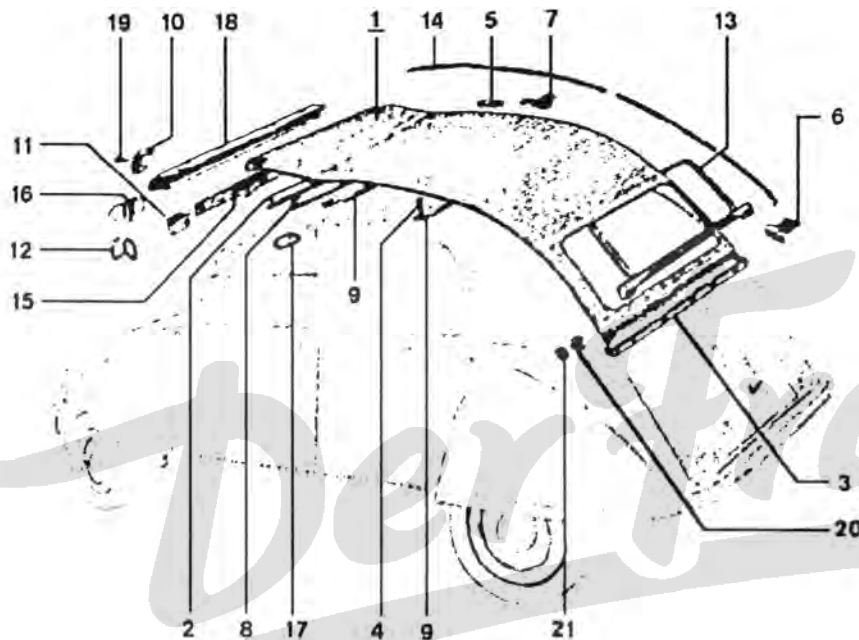

1117

[6/89]

08 9710 10

29710100

**SPECIALE**

01	95 596 986 VT	01	AVEC GLACE RMP 5477195600	2245 ▶	<b>CAPOTE NUE</b> VERDECK NACKT TOP ONLY CAPOTA SUELTA CAPOTE NUDA
02	A 971 64	01	AV		<b>PROFILE</b> SCHUTZLEISTE SECTION JUNTA PROTECCI. PROFILATO PROT

03	AZ 971 67	02	AR	<b>TRAVERSE</b> TRAVERSE FIX CROSSMEMBER TRAVIESA TRAVERSA
04	5 419 960	04	LON 9 RMP 7903072163 LON12	<b>RIVET</b> NIET RIVET REMACHE RIVETTO
05	A 971 74	02		<b>RENFORT</b> VERSTAERKUNG REINFORCEMENT REFUERZO RINFORZO
06	AZ 971 79 A	02	LAT-AR	<b>CROCHET</b> HAKEN CANVAS HOOK GANCHO FIJACION GANCIO
07	AZ 971 79	02	LAT	-
08	A 971 80 A	01	AV	<b>JOINT CAOUTCHOU</b> GUMMIDICHTUNG RUBBER SEAL JUNTA GOMA GUARNIZIONE GOM
09	A 971 69	02	RMP A97182A 1575 ▶	<b>ARCEAU DE BACHE</b> VERDECKSPRIEGEL CANVAS BOW BARRA DE TECHO TENDITORE TELO
10	A 971 83	02	AV	<b>CROCHET</b> HAKEN CANVAS HOOK GANCHO FIJACION GANCIO
11	A 971 84	02		<b>EMBOUT</b> ENDSTUECK SOCKET TOOL TERMINAL TERMINALE
12	A 971 85	02		<b>POIGNEE</b> GRIFF LOCK HANDLE EMPUNADURA MANIGLIA

.../...

15/02/91  
 1117 08-9710-10  
 PAGE : 2  
 D05 ↓

**CAPOTE**  
 ROLLVERDECK  
 HOOD  
 CAPOTA  
 CAPOTE

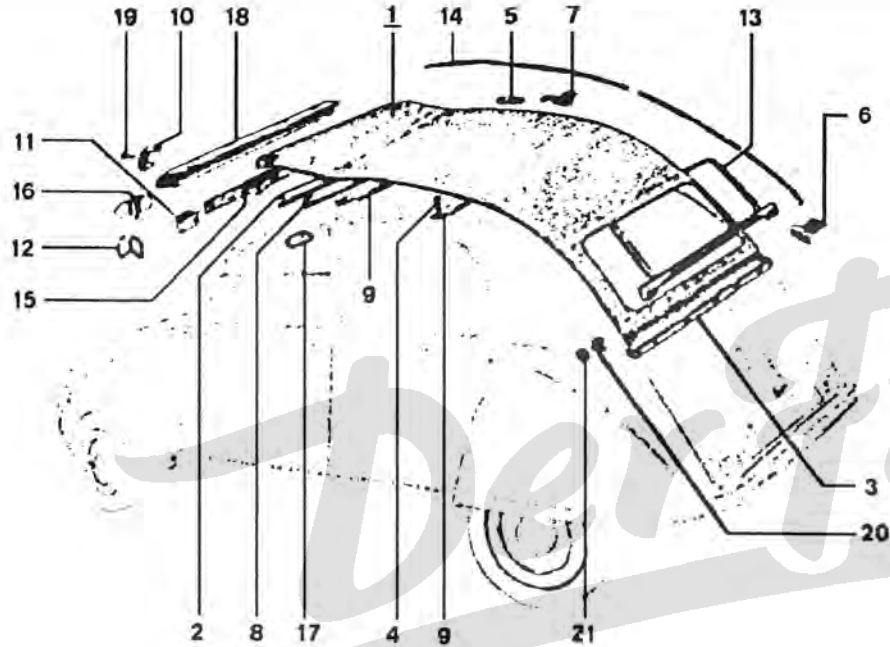

1117

[6/89]

08 9710 10

Z9710100

**SPECIALE**

13	AZ 971 86	01	ENCADREMENT RAHMEN WINDOW FRAME MARCO DE LUNA INTELAIATURA
14	AZ 971 90	02	TENDEUR ARCEAU SPRIEGELPLANNE BOW TENSIONER TENSOR BARRA TENDICENTINA

15	A 971 93	01	SANGLE SPANNBAND TARPAULIN STRAP TENSOR CINGHIA
16	AZ 971 98	01 G- AV	EMBOUT ENDSTUECK SOCKET TOOL TERMINAL TERMINALE
17	AZ 971 98 A	01 D- AV	-
17	AY 971 100	04	1575 ▶ GAINE SCHUTZHUELLE PROTECT SHEATH VAINA GUAINA
18	A 971 99	01 AV	TRAVERSE TRAVERSE FIX CROSSMEMBER TRAVIESA TRAVERSA
19	20 964 009	99 3,5X10	VIS TF SCHRAUBE CAPSCREW TORNILLO VITE
19	79 03 016 008	99 DIAM 4,2X9.5	VIS TCB SCHRAUBE CAPSCREW TORNILLO TCB VITE
20	ZC 9615 725 U	02	ECROU MUTTER NUT TUERCA DADO
21	5 447 635	08	RONDELLE ETC DICHTSCHEIBE SEAL WASHER ARANDELA RONDELLA

.../...



15/02/91  
1117 08-9710-10  
PAGE :3  
D04 ↓

**CAPOTE**  
ROLLVERDECK  
HOOD  
CAPOTA  
CAPOTE

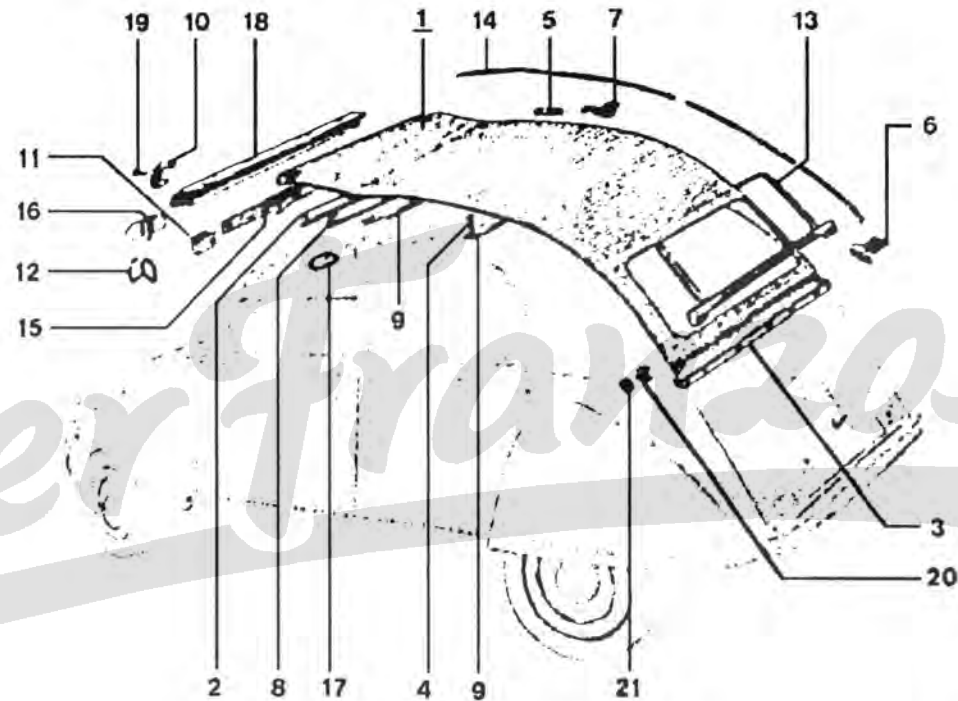

1117

[6/89]

08 9710 10

Z9710100

**SPECIALE**

**XT**

51

95 596 981 FMB

01 -(S) -(GB)

3087 ▶

**CAPOTE NUE**  
**VERDECK NACKT**  
**TOP ONLY**  
**CAPOTA SUELTA**  
**CAPOTE NUDA**

15/02/91  
1117 08-9713-11  
PAGE : 1  
D03 ↓

**CAPOTE AVEC PORTIQUE**  
**ROLLVERDECK MIT RAHMENSTANGE**  
**HOOD WITH FRAME ASSY**  
**CAPOTA CON PORTICO**  
**CAPOTE CON PORTICO**

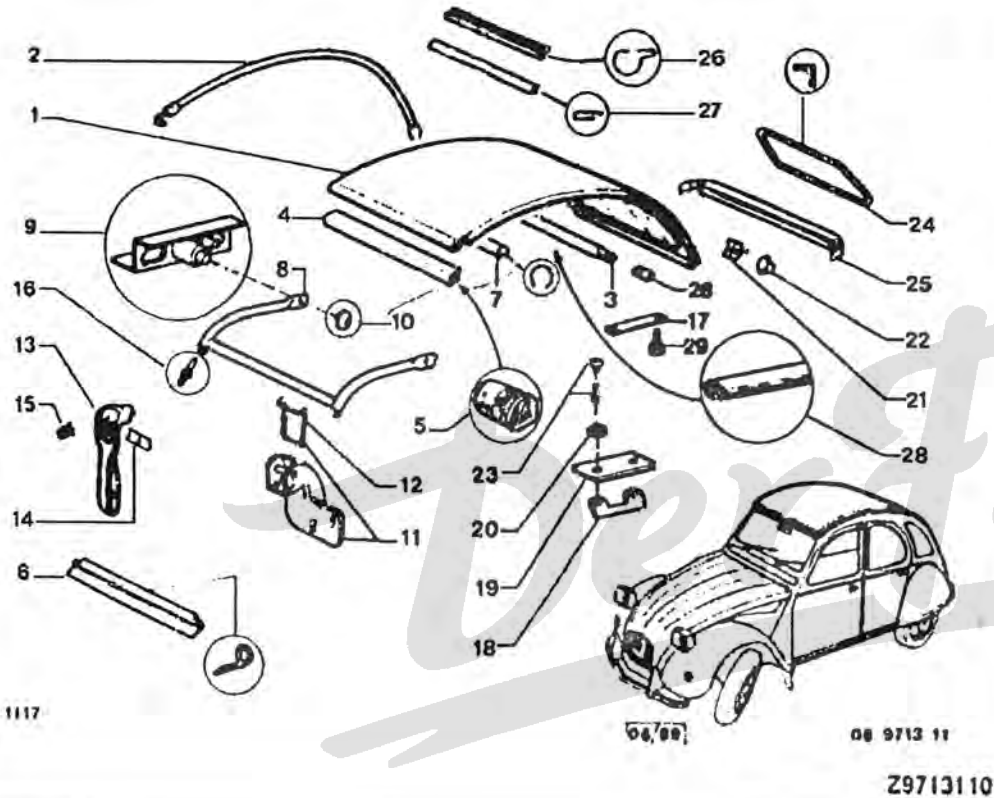

01 5 454 944\*103  
RP 95596081VT

95 596 981 VT

95 596 981 NW  
RP 95596981VT

95 596 981 WB

01  
01  
01  
01

**CAPOTE NUE**  
**VERDECK NACKT**  
**TOP ONLY**  
**CAPOTA SUELTA**  
**CAPOTE NUDA**

01  
02  
03  
04  
05  
06  
07

95 596 981 DB  
RP 95596981VT

95 596 981 EKB

95 596 981 EVP  
RP 95596981VT

95 596 981 EAA

95 596 981 FMB

95 593 803  
RP 95596981WB

AZ 971 90

A 971 69

5 454 940

5 454 941

5 454 942

A 971 80 A

A 971 64

01  
01  
01  
01  
01  
01  
02  
02  
01  
01  
01  
01  
01  
01  
01  
01  
01  
01

TRANSC DE 95596981VP

FRANCE 3

RMP A97182A

AV

G-

D-

AV

AV

**CAPOTE NUE**  
**VERDECK NACKT**  
**TOP ONLY**  
**CAPOTA SUELTA**  
**CAPOTE NUDA**

**TENDEUR ARCEAU**  
**SPRIEGELPLANNE**  
**BOW TENSIONER**  
**TENSOR BARRA**  
**TENDICENTINA**

**ARCEAU DE BACHE**  
**VERDECKSPRIEGEL**  
**CANVAS EOW**  
**BARRA DE TECHO**  
**TENDITORE TELO**

**TRAVERSE**  
**TRAVERSE**  
**FIX CROSSMEMBER**  
**TRAVIESA**  
**TRAVERSA**

**EMBOUT**  
**ENDSTUECK**  
**SOCKET TOOL**  
**TERMINAL**  
**TERMINALE**

**JOINT CAOUTCHOU**  
**GUMMIDICHTUNG**  
**RUBBER SEAL**  
**JUNTA GOMA**  
**GUARNIZIONE GOM**

**PROFILE**  
**SCHUTZLEISTE**  
**SECTION**  
**JUNTA PROTECCI.**  
**PROFILATO PROT**

.../...

15/02/91  
 1117 08-9713-11  
 PAGE : 2  
 D02 ↓

**CAPOTE AVEC PORTIQUE**  
 ROLLVERDECK MIT RAHMENSTANGE  
 HOOD WITH FRAME ASSY  
 CAPOTA CON PORTICO  
 CAPOTE CON PORTICO

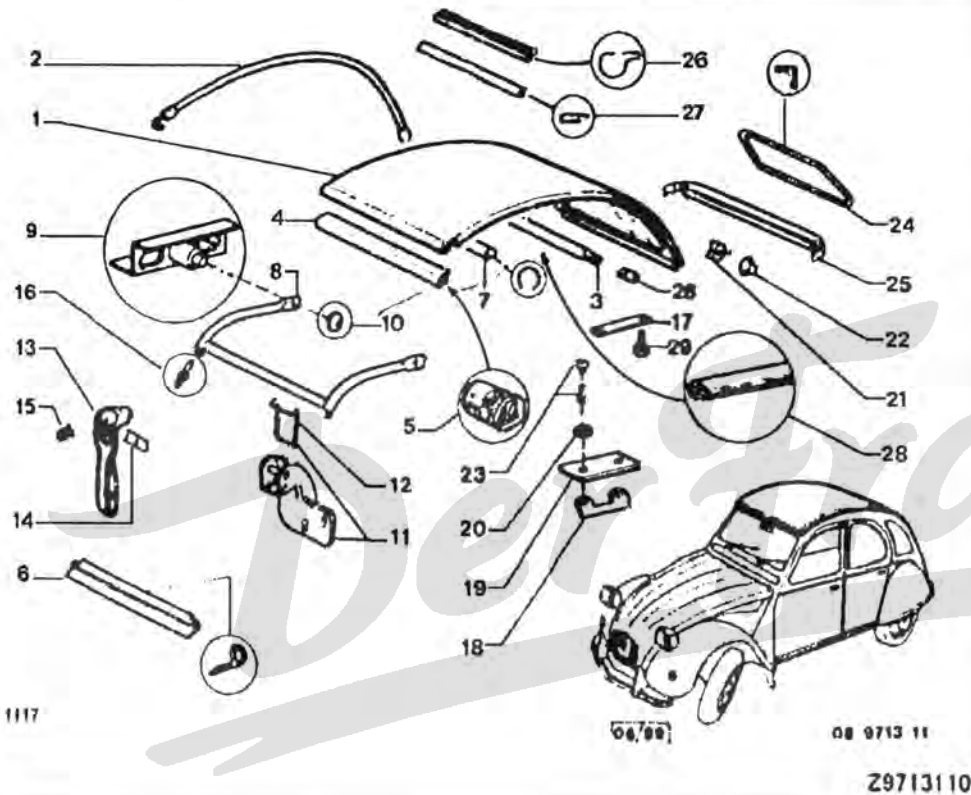

1117

08/99

08 9713 11

Z9713110

08	5 454 946	01
09	5 454 949	02

**TRAVERSE**  
 TRAVERSE  
 FIX CROSSMEMBER  
 TRAVIESA  
 TRAVERSA

**SUPPORT**  
 HALTER  
 TOP FIX BRACKET  
 SOPORTE  
 SUPPORTO

10	26 240 409	02	<b>ENJOLIVEUR</b> ZIERSTUECK POST MOULDING EMBELLECEDOR PROFILO
11	5 475 242	01 G- ENS	<b>CROCHET</b> HAKEN CANVAS HOOK GANCHO FIJACION GANCIO
	5 475 243	01 D- ENS	-
12	5 454 953	02	-
13	AY 971 111	01	<b>POIGNEE</b> GRIFF TOP PULL HANDLE TIRADOR MANIGLIA
14	AY 971 76	01	<b>PLAQUETTE</b> PLATTE FIXING PLATE PLAQUETA PIASTRINA
15	79 03 044 023	02 DIAM 5X0,80 RMP 26158069	<b>ECROU EN CAGE</b> KAFIGMUTTER CAGED NUT TUERCA EN CAJA DADO IN CABBIA
16	AY 971 103	02	<b>GOUJON</b> STEBBOLZEN STUD ESPARRAGO PERNO
17	AY 971 122	02	<b>SANGLE</b> SPANNBAND TARPAULIN STRAP TENSOR CINGHIA
18	5 460 390	02 LAT	<b>CROCHET</b> HAKEN CANVAS HOOK GANCHO FIJACION GANCIO
19	A 971 74	02	<b>RENFORT</b> VERSTAERKUNG REINFORCEMENT REFUERZO RINFORZO

.../...

15/02/91  
1117 08-9713-11  
PAGE : 3  
D01 →

**CAPOTE AVEC PORTIQUE**  
**ROLLVERDECK MIT RAHMENSTANGE**  
**HOOD WITH FRAME ASSY**  
**CAPOTA CON PORTICO**  
**CAPOTE CON PORTICO**

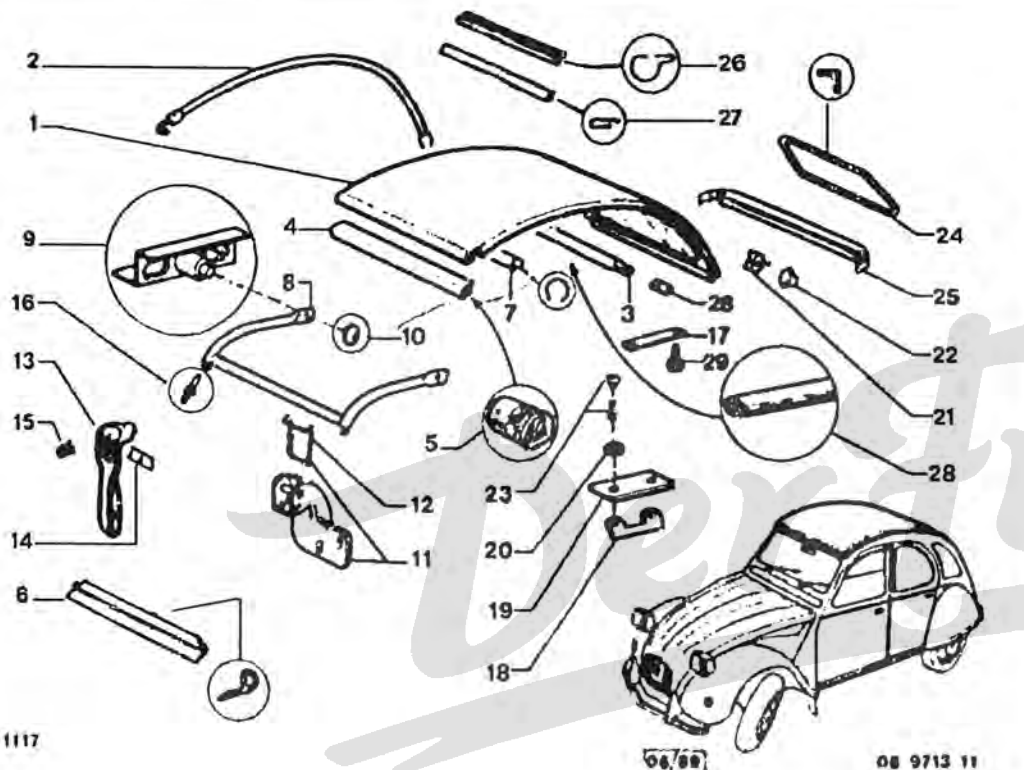

20 \* 5 447 635

04

**RONDELLE ETC**  
**DICHTSCHEIBE**  
**SEAL WASHER**  
**ARANDELA**  
**RONDELLA**

21 AY 971 68

02

**ENTRETOISE**  
**ABSTANDSSTUECK**  
**SPACER**  
**JUEGO DISTANCIA**  
**DISTANZIALE**

22	26 131 719	07	MALE- RMP AY971107A	BOUTON DE FIX KNOPF FIXING KNOB BOTON FIJACION BOTTONE FISSAGG
23	5 419 960	04	LON 9 RMP 7903072163 LON 12	RIVET NIET RIVET REMACHE RIVETTO
24	AZ 971 86	01		▶ 2244 ENCADREMENT RAHMEN WINDOW FRAME MARCO DE LUNA INTELAIATURA
	95 595 526	01		2245 ▶ -
25	AZ 971 67	01	AR	TRVERSE TRVERSE FIX CROSSMEMBER TRAVIESA TRAVERSA
26	95 593 162	01	LON 880	2245 ▶ GARNITURE BEZUG LINING GUARNECIDO RIVESTIMENTO
27	95 595 863	01	LON 740	2245 ▶ PROTECTEUR SCHUTZ BOW PROTECTOR PROTECTOR PROTEZIONE
28	AY 971 100	04		1375 ▶ GAINÉ SCHUTZHUELLE PROTECT SHEATH VAINA GUAINA
29	79 03 016 140	99	DIAM 3,5 - 16 RMP 22610069	VIS TOLE TF BLECHSCHRAUBE TAPPING SCREW TORNILLO R CHAP VITE LAMIERA

.../...

15/02/91  
 1117 08-9713-11  
 PAGE : 4  
 E01 ↑

**CAPOTE AVEC PORTIQUE**  
 ROLLVERDECK MIT RAHMENSTANGE  
 HOOD WITH FRAME ASSY  
 CAPOTA CON PORTICO  
 CAPOTE CON PORTICO

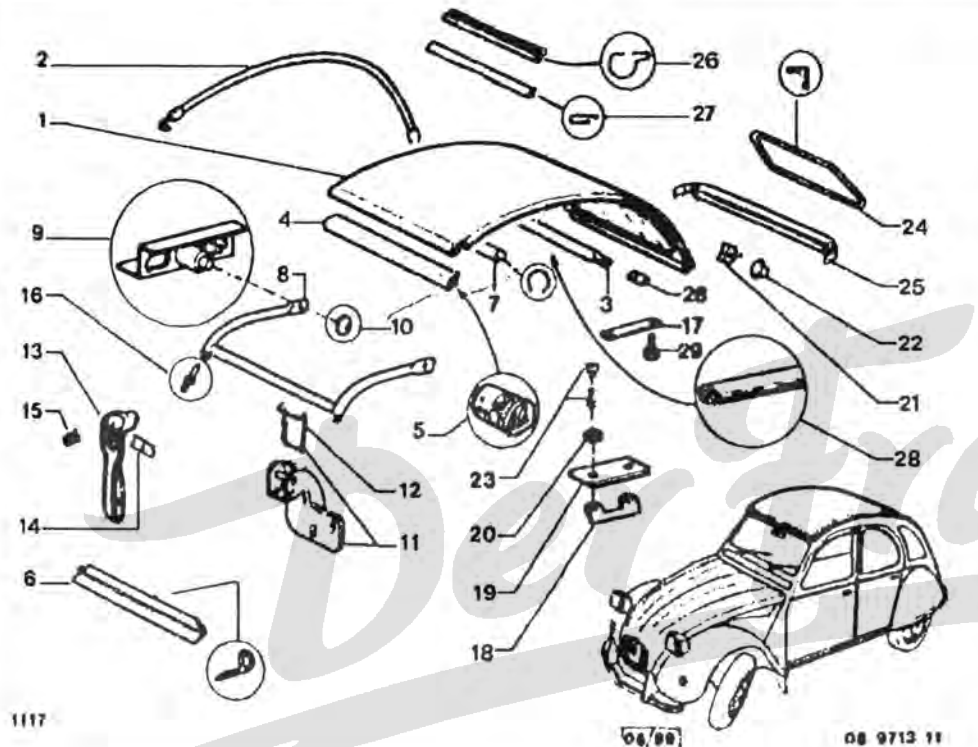

51	95 602 952 WT	01	-(DK) AVEC GLACE CHAUFFANTE	3737 ▶	CAPOTE NUE VERDECK NACKT TOP ONLY CAPOTA SUELTA CAPOTE NUDA
	95 602 952 KB	01	-(DK) AVEC GLACE CHAUFFANTE	3737 ▶	-
	95 602 952 MB	01	-(DK) AVEC GLACE CHAUFFANTE	3737 ▶	-
	95 602 952 VM	01	-(DK) AVEC GLACE CHAUFFANTE	3737 ▶	-
76	95 560 509	01	LON 856 -(B)	1515 ▶	GARNITURE UMMANTELUNG MIT MBER LINING GUARNECIDO RIVESTIMENTO
80	95 547 033	02	-(B)		PROTECTEUR SCHUTZ BOW PROTECTOR PROTECTOR PROTEZIONE
81	95 548 781	01	G. -(B)		-
	95 548 780	01	D. -(B)		-

<b>XT</b>					
51	95 602 952 NA RP 95602952NW	01	-(B) AVEC GLACE CHAUFFANTE	2426 ▶ 2489	CAPOTE NUE VERDECK NACKT TOP ONLY CAPOTA SUELTA CAPOTE NUDA
	95 602 952 NW	01	-(B) AVEC GLACE CHAUFFANTE	2488 ▶	-

15/02/91  
 1117 08-9792-10  
 PAGE : 1  
 E02 ↑

**TAPIS**  
 CARPETS - LINING  
 ALFOMBRAS - GUARNECIDOSCR9821  
 TAPPETI - RIVESTIMENTI  
 CAPOTE CON PORTICO

51

95 539 970

01 CAOUTCHOUC  
 -CAD

**XT**

TAPIS AV  
 VORD MATTE  
 FLOOR FRONT MAT  
 ALFOMBRA AV  
 TAPPETO ANT.

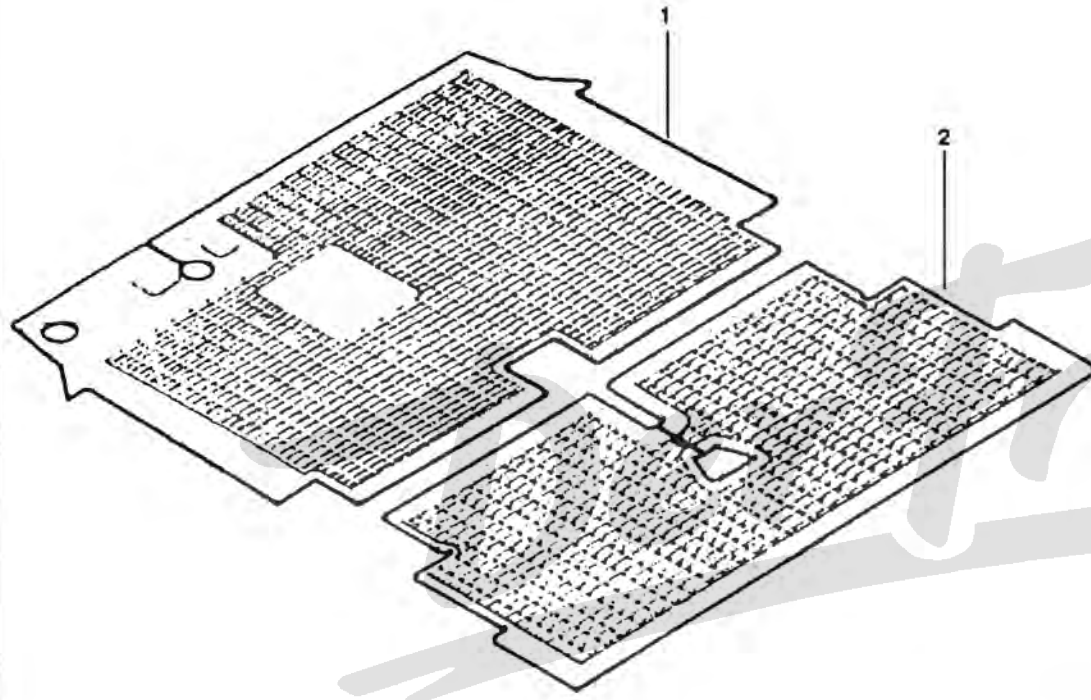

1114

8.981.10  
 29792100

01	95 539 858	01	CAOUTCHOUC	TAPIS AV VORD FLOOR FRONT MAT ALFOMBRA AV TAPPETO ANT.
02	5 486 149	01	RMP 5486150	TAPIS AR MATTE FLOOR REAR MAT ALFOMBRA AR TAPPETO POST.

15/02/91  
 1117 08-9796-10  
 PAGE : 1  
 E03 ↑

**GARNITURES INTERIEURES**  
 INNERE BEZUEGE  
 INNER LINING  
 GUARNECIDOS INTERIORES  
 RIVESTIMENTI INTERNI

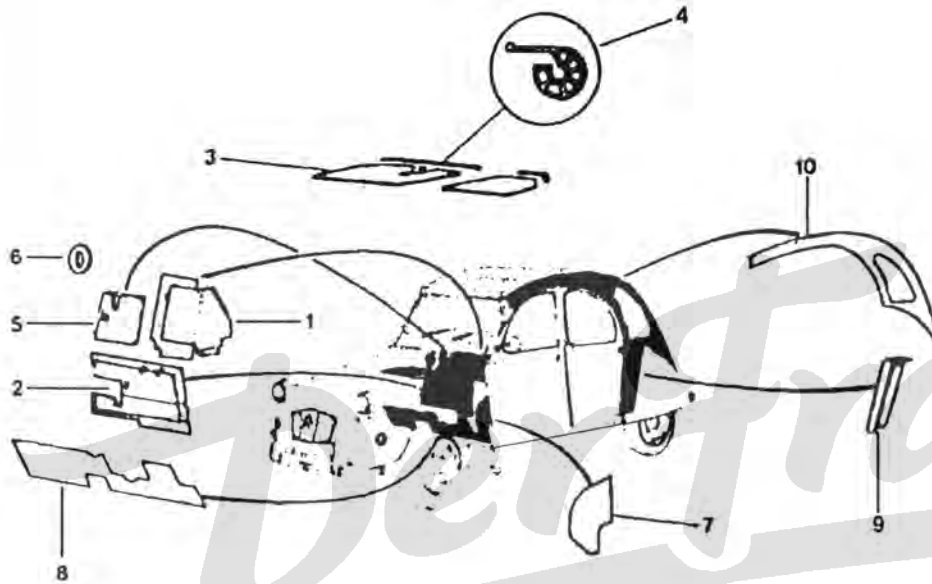

1114

8.982.10  
 Z9796100

01	95 562 218	01	G- SUP RMP 5424393-5503434	GARNITURE BEZUG BULKHEAD LINING GUARNECIDO RIVESTIMENTO	03	5 424 398	01	D-	GARNITURE BEZUG BULKHEAD LINING GUARNECIDO RIVESTIMENTO
	5 424 394	01	D- SUP	-	04	AZ 987 75	01	G-	BOURRELET SCHUTZWULST CRASH PAD BURLETE PROTEC. BORDO
02	5 424 395	01	G- INF	-	05	5 424 412	01		GARNITURE BEZUG GLOVE-BX LINING GUARNECIDO RIVESTIMENTO
	75 526 495	01	D- INF	-	06	5 424 413	01	FEUTRE ENDUIT	RONDELLE ETC DICHTSCHEIBE SEAL WASHER ARANDELA RONDELLA
03	5 424 397	01	G-	-	07	AZ 986 296 A	01	G-	GARNITURE BEZUG COWL LINING GUARNECIDO RIVESTIMENTO
						AZ 986 297 A	01	D-	-
					08	5 424 480	01		INSONO PLANCHER GERAEUSCHDAEMM. SOUND PROOFING INSONORIZANTE INSONORIZAZION
						AZ 982 270 A	01		-
					09	5 412 884	01	G-	GARNITURE BEZUG WHL HOUS LINING GUARNECIDO RIVESTIMENTO
						5 412 885	01	D-	-
					10	AZ 986 246 A	01	G-	PANNEAU GARNI. FUELLUNG RR LINING PANEL PANEL GUARNECI PANNELLO
						AZ 986 245 A	01		-

...!

15/02/91  
 1117 08-9796-10  
 PAGE : 2  
 E04 ↑

**GARNITURES INTERIEURES**  
 INNERE BEZUEGE  
 INNER LINING  
 GUARNECIDOS INTERIORES  
 RIVESTIMENTI INTERNI

52

75 526 496

01 D- INF  
 -CAD

GARNITURE  
 BEZUG  
 BULKHEAD LINING  
 GUARNECIDO  
 RIVESTIMENTO

53

5 468 046

01 G-  
 -CAD

-

5 424 398

01 D-  
 -CAD  
 RMP 5468047

-

61

75 529 279

01 -(D) 1515 ▶

PROFILE  
 ABSCHLUSSPROFIL  
 FINISHER PANEL  
 PERFIL  
 PROFILO FINITUR

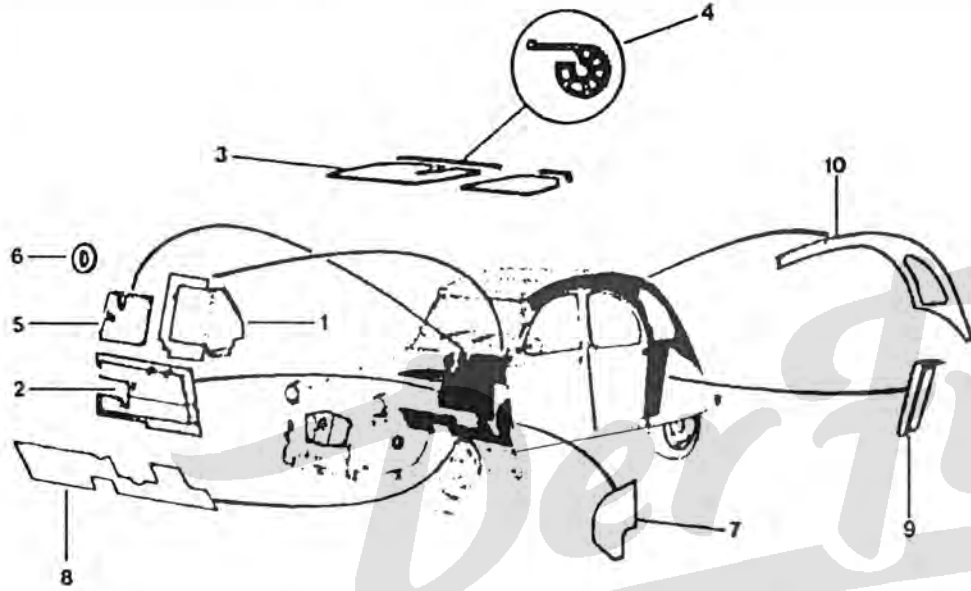

1114

8.982.10  
 Z9796100

**XT**

51

5 487 330

01 G- SUP  
 -CAD  
 RMP 5467457

GARNITURE  
 BEZUG  
 BULKHEAD LINING  
 GUARNECIDO  
 RIVESTIMENTO

52

5 467 455

01 G- INF  
 -CAD

-



15/02/91  
 1117 08-9828-10  
 PAGE : 1  
 E05 ↑

**PANNEAUX DE PORTE AVANT**  
 TUERFUELLUNGEN FRONT  
 DOOR TRIMMING PANELS FRONT  
 PANELES DE PUERTAS DELANTERAS  
 PANNELLI PER PORTIERE ANT.

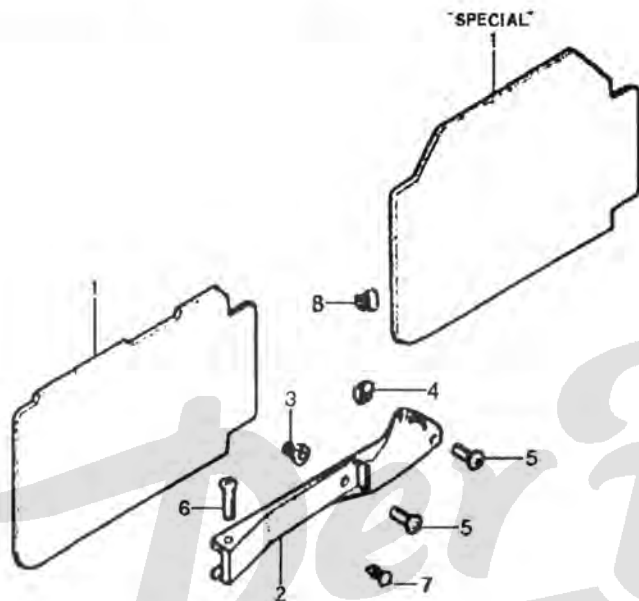

1114

8.983.10

Z9828100

01	95 500 948 EE	01 G- TEP GRAIN CUIR LIEGE ▶ 2426	PANNEAU GARNI. TUERVERKEIDUNG UPHOLSTR PANEL PANEL GUARNECI. PANNELLO
	95 500 948 AR	01 G- TEP GRAIN CUIR LIEGE 2245 ▶ 3104	-
	95 612 773 FTM	01 G- TEP GRAIN CUIR LIEGE -CLUB 3105 ▶	-

01	95 612 769 FTM	01 G- TEP GRAIN CUIR LIEGE -SPECIALE 3105 ▶	PANNEAU GARNI. TUERVERKEIDUNG UPHOLSTR PANEL PANEL GUARNECI. PANNELLO
	95 500 946 FXX	01 G- TEP GRAIN CUIR LIEGE	-
	95 501 386 AR	01 G- TEP GRAIN CUIR LIEGE -SPECIALE 2427 ▶	-
	95 501 386 NG	01 G- TEP GRAIN CUIR LIEGE -FRANCE 3	-
	95 500 949 EE	01 D- TEP GRAIN CUIR LIEGE ▶ 2426	-
	95 500 949 FXX	01 D- TEP GRAIN CUIR LIEGE	-
	95 501 387 AR	01 D- TEP GRAIN CUIR LIEGE -SPECIALE 2427 ▶	-
	95 501 387 NG	01 D- TEP GRAIN CUIR LIEGE -FRANCE 3	-
	95 500 949 AR	01 D- TEP GRAIN CUIR LIEGE 2426 ▶ 3104	-
	95 612 772 FTM	01 D- TEP GRAIN CUIR LIEGE -CLUB 3105 ▶	-
	95 612 768 FTM	01 D- TEP GRAIN CUIR LIEGE -SPECIALE 3105 ▶	-
	95 501 386 EE	01 G- TEP GRAIN CUIR LIEGE -SPECIALE ▶ 2429	-
	95 501 386 FXX	01 G- TEP GRAIN CUIR LIEGE -SPECIALE TRANSC DE 95501386XA	-
	95 501 387 EE	01 D- TEP GRAIN CUIR LIEGE -SPECIALE ▶ 2429	-

.../...

15/02/91  
1117 08-9828-10  
PAGE : 2  
E06 ↑

**PANNEAUX DE PORTE AVANT**  
TUERFUELLUNGEN FRONT  
DOOR TRIMMING PANELS FRONT  
PANELES DE PUERTAS DELANTERAS  
PANNELI PER PORTIERE ANT.

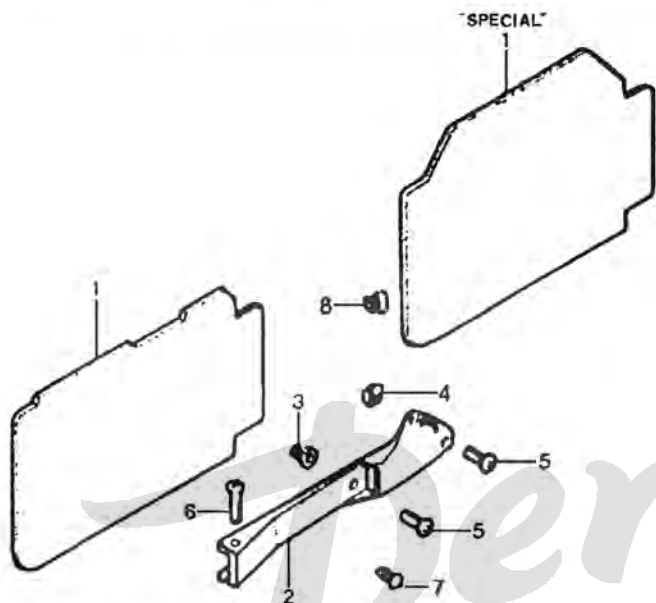

1114

B.982.10

Z9828100

01 95 501 387 FXX

01 D-  
TEP GRAIN CUIR LIEGE  
-SPECIALE

PANNEAU GARNI.  
TUERVERKEIDUNG  
UPHOLSTR PANEL  
PANEL GUARNECI.  
PANNELLO

03 5 453 675\*700

01 G- SUP-AV

BANDEAU  
ZIERBAND  
DOOR CAPPING  
EMBELLECEDOR  
PROFILO

5 453 676\*700

01 D- SUP-AV

03	26 159 649	02	DIAM 4	ECROU TOLE BLECHMUTTER SPEED NUT TUERCA CHAPA DADO LAMIERA
04	26 159 659	02	CAGE 4X0.70	ECROU EN CAGE KAFIGMUTTER CAGED NUT TUERCA EN CAJA DADO IN GABBIA
05	26 225 499	06	DIAM 4X0.70X16	VIS TCB SCHRAUBE CAPSCREW TORNILLO TCB VITE
06	24 701 009	04	TFB4X070 LON16 RMP ZD9467530Z	VIS TF SCHRAUBE CAPSCREW TORNILLO VITE
07	26 199 699	02		SUPPORT HALTER LINE BRACKET SOPORTE SUPPORTO
08	26 197 629	15		AGRAFE KLAMMER CLIP GRAPA AGRAFE
<b>XT</b>				
51	95 500 948 NG	01	G- TEP GRAIN CUIR LIEGE -FRANCE 3 -(D)	PANNEAU GARNI. TUERVERKEIDUNG UPHOLSTR PANEL PANEL GUARNECI. PANNELLO
	95 500 949 NG	01	D- TEP GRAIN CUIR LIEGE -FRANCE 3 -(D)	.
	95 500 948 EC NFP	01	G- TEP -(D)	.
			2670 ▶	
	95 500 949 EC	01	D- TEP -(D)	.
			2670 ▶	

.../...

15/02/91  
 1117 08-9828-10  
 PAGE : 3  
 E07 ↑

**PANNEAUX DE PORTE AVANT**  
 TUERFUELLUNGEN FRONT  
 DOOR TRIMMING PANELS FRONT  
 PANELES DE PUERTAS DELANTERAS  
 PANNELLI PER PORTIERE ANT.

51

95 500 948 FDA

01 -(CH)

3614 ▶

PANNEAU GARNI.  
 TUERVERKEIDUNG  
 UPHOLSTR PANEL  
 PANEL GUARNECI.  
 PANNELLO

95 500 949 FDA

01 D-  
 BEIGE DAIM  
 TEP GRAIN CUIR LIEGE  
 -(CH)  
 -(D) -ECOLOGISTE

3402 ▶  
 3614 ▶

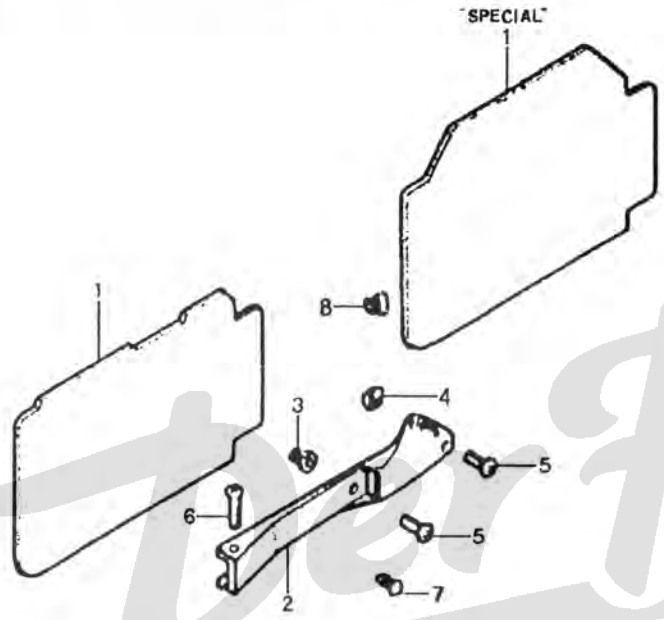

1114

8.983.10

Z9828100

51	95 500 948 FYC	01 G- TEP -(D)	3035 ▶	PANNEAU GARNI. TUERVERKEIDUNG UPHOLSTR PANEL PANEL GUARNECI. PANNELLO
	95 500 949 FYC	01 D- TEP -(D)	3035 ▶	.
	95 500 948 FDA	01 G- BEIGE DAIM TEP GRAIN CUIR LIEGE -(D) -ECOLOGISTE	3402 ▶	.

**PANNEAUX DE PORTE ARRIERE**  
 HINTERE TUERFUELLUNGEN  
 REAR DOOR PANELS  
 PANELES DE PUERTAS TRASERAS  
 PANNELLI PER PORTIERE POSTERIORI

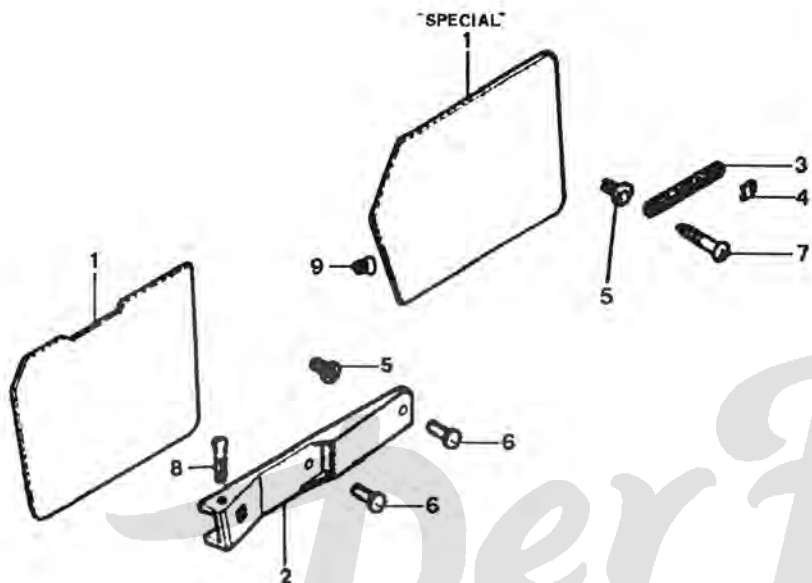

1117 [6/89] 08 9829.20 29829200

01	95 500 954 FXX	01	G- TEP GRAIN CUIR LIEGE	PANNEAU GARNI. TUERVERKEIDUNG UPHOLSTR PANEL PANEL GUARNECI. PANNELLO
	95 508 073 AR	01	G- TEP GRAIN CUIR LIEGE -SPECIALE	
	95 508 073 NG	01	G- BLEU OCEAN TEP GRAIN CUIR LIEGE -FRANCE 3	
	95 612 777 FTM	01	G- GRIS MOYEN TEP GRAIN CUIR LIEGE -SPECIALE	3096 ▶
	95 500 955 AR	01	D- TEP GRAIN CUIR LIEGE	▶ 3096
	95 612 780 FTM	01	D- TEP GRAIN CUIR LIEGE -CLUB	3096 ▶
	95 500 955 EE	01	D- TEP GRAIN CUIR LIEGE	
	95 500 955 FXX	01	D- TEP GRAIN CUIR LIEGE	
	95 508 077 NG	01	D- TEP GRAIN CUIR LIEGE -FRANCE 3	
	95 508 077 AR	01	D- TEP GRAIN CUIR LIEGE -SPECIALE	
	95 612 776 FTM	01	D- TEP GRAIN CUIR LIEGE -SPECIALE	05/85 ▶
	95 508 073 EE	01	G- TEP GRAIN CUIR LIEGE -SPECIALE	
	95 508 073 FXX	01	G- TEP GRAIN CUIR LIEGE -SPECIALE	
	95 508 077 EE	01	G- TEP GRAIN CUIR LIEGE -SPECIALE	

15/02/91  
1117 08-9829-20  
PAGE : 2  
E09 ↑

**PANNEAUX DE PORTE ARRIERE**  
HINTERE TUERFUELLUNGEN  
REAR DOOR PANELS  
PANELES DE PUERTAS TRASERAS  
PANNELLI PER PORTIERE POSTERIOR

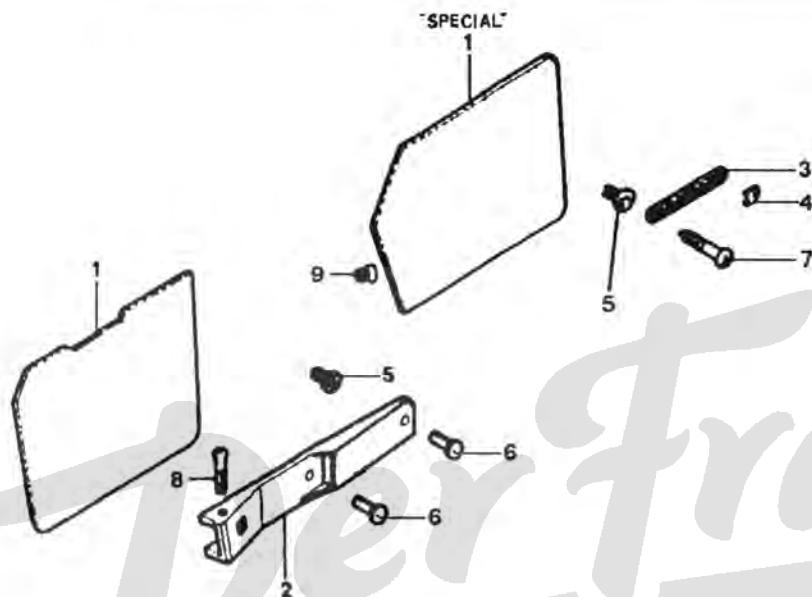

1117

6/89

08 9829.20  
Z9829200

03	5 443 999	02	-SPECIALE	BRIDE MAINTIEN HALTESTEG FLANGE BRIDA SUJECION STAFFA TENUTA
04	AZ 841 126	04	-SPECIALE	EMBOUIT ENDSTUECK SOCKET TOOL TERMINAL TERMINALE
05	26 159 649	04	DIAM 4	ECROU TOLE BLECHMUTTER SPEED NUT TUERCA CHAPA DADO LAMIERA
06	26 225 499	06	DIAM 4X0,70X16	VIS TCB SCHRAUBE CAPSCREW TORNILLO TCB VITE
07	24 677 069	02	TFB 4X25	VIS TOLE TF BLECHSCHRAUBE TAPPING SCREW TORNILLO R CHAP VITE LAMIERA
08	24 701 009	02	TFB4X070LON16 RMP ZD9487530Z	VIS TF SCHRAUBE CAPSCREW TORNILLO VITE
09	26 197 629	14		AGRAFE KLAMMER CLIP GRAPA AGRAFE
51	95 500 954 NG	01	<b>XT</b> G- TEP GRAIN CUIR LIEGE -FRANCE 3 -(D)	PANNEAU GARNI. TUERVERKEIDUNG UPHOLSTR PANEL PANEL GUARNECI. PANNELLO
	95 500 955 NG	01	D- TEP GRAIN CUIR LIEGE -FRANCE 3 -(D)	BANDEAU ZIERBAND DOOR CAPPING EMBELLECEDOR PROFILO

01	95 508 077 FXX	01	D- TEP GRAIN CUIR LIEGE -SPECIALE	PANNEAU GARNI. TUERVERKEIDUNG UPHOLSTR PANEL PANEL GUARNECI. PANNELLO
02	5 453 683*700	01	G- SUP	BANDEAU ZIERBAND DOOR CAPPING EMBELLECEDOR PROFILO
	5 453 684*700	01	D- SUP	-

.../...

**PANNEAUX DE PORTE ARRIERE**  
 HINTERE TUERFUELLUNGEN  
 REAR DOOR PANELS  
 PANELES DE PUERTAS TRASERAS  
 PANNELLI PER PORTIERE POSTERIORI

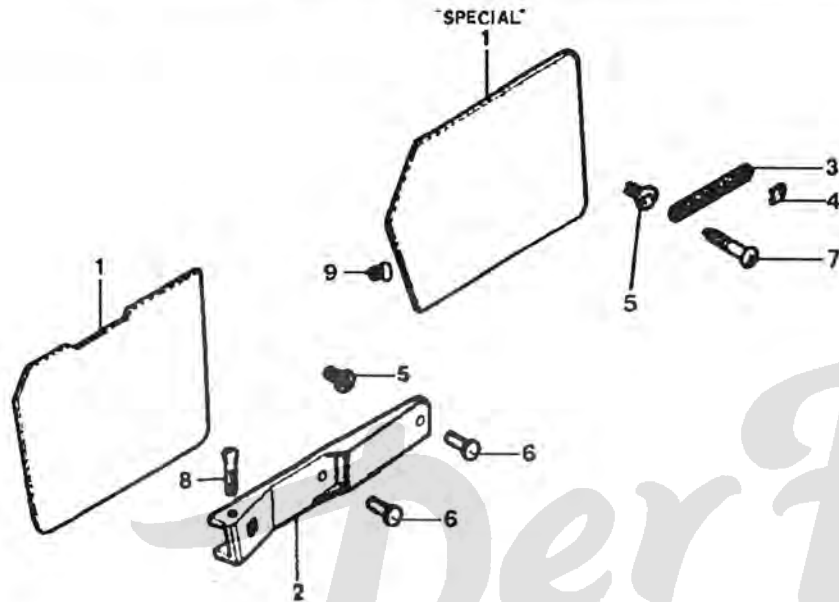

1117

08/99

08 9829.20  
 Z9829200

51	95 500 955 FYC	01	D- TEP -(D)	3038 ▶	PANNEAU GARNI. TUERVERKEIDUNG UPHOLSTR PANEL PANEL GUARNECI. PANNELLO
	95 500 954 FDA	01	G- BEIGE DAIM TEP GRAIN CUIR LIEGE -(D) -ECOLOGISTE -(CH)	3420 ▶ 3622 ▶	-
	95 500 955 FDA	01	D- BEIGE DAIM TEP GRAIN CUIR LIEGE -(D) -ECOLOGISTE -(CH)	3420 ▶ 3622 ▶	-
1	95 500 954 EC NFP	01	G- TEP -(D)	2870 ▶	PANNEAU GARNI. TUERVERKEIDUNG UPHOLSTR PANEL PANEL GUARNECI. PANNELLO
	95 500 955 EC NFP	01	D- TEP -(D)	-	-
	95 500 954 FYC	01	G- TEP -(D)	3038 ▶	-

NUMERO	SOUS-GROUPE	REP	NUMERO	SOUS-GROUPE	REP	NUMERO	SOUS-GROUPE	REP	NUMERO	SOUS-GROUPE	REP
5 403 022	08-6132-10	19	5 486 149	08-9792-10	02	95 494 814	08-6223-10	02	5 505 320*700		54
5 410 853	08-9344-12	03	5 486 647	08-9225-21	06	95 494 691	08-6164-20	02	A 251 1 A	08-6223-10	01
5 412 884	08-9796-10	09	5 487 330	08-9796-10	51	95 494 692		01	A 922 102	08-9343-11	05
5 412 885		09	5 490 745	08-5541-10	62	95 495 667	08-6132-10	51	A 922 114		02
5 413 322	08-9225-21	11	5 490 934		62	95 495 669		01		08-9225-21	10
	08-9225-11	07	5 500 757	08-9343-11	10	95 495 670		01		08-9225-11	06
5 419 960	08-9710-10	04	5 500 758		10	95 495 799	08-5541-10	07	A 971 64	08-9713-11	07
	08-9713-11	23	5 505 253	08-9225-21	01	95 539 858	08-9792-10	01		08-9710-10	02
5 424 394	08-9796-10	01	5 505 255		05	95 539 970		51	A 971 69		09
5 424 395		02	5 505 276		51	95 547 033	08-9713-11	80		08-9713-11	03
5 424 397		03	20 964 009	08-9710-10	19	95 548 780		81	A 971 74		19
5 424 398		03	22 363 019	08-9225-21	08	95 548 781		81		08-9710-10	05
		53	22 722 019	08-6164-20	09	95 555 858	08-5541-10	51	A 971 80 A		08
5 424 412		05	23 826 319	08-6132-10	08	95 560 509	08-9713-11	76		08-9713-11	06
5 424 413		06	24 877 069	08-9829-20	07	95 562 218	08-9796-10	01	A 971 83	08-9710-10	10
5 424 480		08	24 701 009		08	95 563 271	08-6164-20	03	A 971 84		11
5 443 999	08-6132-10	03		08-9828-10	06	95 574 003	08-5541-10	01	A 971 85		12
	08-9829-20	03	26 120 279	08-9225-21	17	95 574 004		02	A 971 93		15
5 447 835	08-9713-11	20	26 131 719	08-9713-11	22	95 574 005		51	A 971 99		18
	08-9710-10	21	26 158 649	08-9828-10	03	95 574 006		52	AM 912 111	08-9225-21	07
5 454 940	08-9713-11	04		08-9829-20	05	95 574 007		51	AM 912 4		04
5 454 941		05	26 159 659	08-9828-10	04	95 574 008		52	AM 922 104 E	08-9225-11	08
5 454 942		05	26 193 089	08-6132-10	15	95 577 197		05		08-9343-11	03
5 454 946		08	26 195 699	08-9225-21	09	95 577 193		05	AM 922 109 C		04
5 454 949		09		08-9225-11	10	95 582 741	08-9225-21	01		08-9225-21	13
5 454 953		12	26 197 829	08-9829-20	09	95 582 742		01	AM 922 12 B	08-9225-11	04
5 460 390		18		08-9828-10	08	95 582 743		01		08-9225-21	04
5 467 455	08-9796-10	52	26 199 699		07	95 582 791	08-9226-22	04	AM 922 271 B		07
5 467 824	08-6164-20	03	26 225 499		05	95 583 384		54		08-9225-11	05
5 468 048	08-9796-10	53		08-9829-20	06	95 593 162	08-9713-11	26	AMB 912 100 A	08-9225-21	12
5 469 170	08-6164-20	10	26 240 409	08-9713-11	10	95 593 803		01	AY 554 1 A	08-5541-10	04
5 472 098	08-9226-22	01	75 407 440	08-5541-10	64	95 595 528		24	AY 554 1 B		54
5 472 106		53	75 407 590	08-6132-10	10	95 595 863		27	AY 554 78		61
5 472 107		54	75 416 387		11	95 596 355	08-9343-11	07	AY 912 117	08-9226-22	04
5 472 190	08-9225-11	01	75 418 368		05	95 599 208	08-9348-13	04	AY 912 94		03
5 472 193	08-9221-12	01		08-6164-20	05	95 638 539	08-9220-23	01	AY 922 246 C	08-9344-12	04
5 472 194		01	75 449 950	08-6132-10	06	95 638 540		01	AY 922 60 D		01
5 472 201		02	75 472 683		12	95 638 541	08-9348-13	01	AY 971 100	08-9710-10	17
5 472 202		02	75 473 031		04	96 995 253	08-9225-21	02		08-9713-11	28
5 472 204		03	75 511 626	08-9225-21	01		08-9225-11	02	AY 971 103		16
5 472 205		04	75 511 627		01	96 995 254		03	AY 971 111		13
5 472 648	08-9226-22	53	75 514 338	08-9225-11	13	5 453 875*700	08-9828-10	02	AY 971 122		17
5 475 242	08-9713-11	11	75 517 125	08-9343-11	01	5 453 876*700		02	AY 971 68		21
5 475 243		11	75 517 500		09	5 453 883*700	08-9829-20	02	AY 971 76		14
5 484 807	08-9225-21	03	75 526 495	08-9796-10	02	5 453 884*700		02	AZ 554 1 A	08-5541-10	03
5 484 809		54	75 526 496		52	5 454 944*103	08-9713-11	01	AZ 554 2 A		05
5 486 015		19	75 527 461	08-9226-22	02	5 500 536*700	08-9222-13	01	AZ 651 110	08-9348-13	06
5 486 016		20	75 527 462	08-9344-12	02	5 505 268*700	08-9220-23	02		08-9343-11	08
5 486 017		22	75 528 608	08-9226-22	02	5 505 283*700		01	AZ 651 126 A	08-9348-13	05
5 486 018		21	75 528 609	08-9344-12	02	5 505 310*700		53		08-9343-11	06
5 486 019		18	75 529 279	08-9796-10	61	5 505 317*700		53	AZ 651 236 A	08-9345-13	04

NUMERO	SOUS-GROUPE	REP	NUMERO	SOUS-GROUPE	REP	NUMERO	SOUS-GROUPE	REP	NUMERO	SOUS-GROUPE	REP
AZ 651 47		05	79 03 056 005	08-6132-10	13	95 501 386 AR	08-9828-10	01	95 595 300 AS	08-9348-13	01
	08-9343-11	07	79 03 056 012	08-9225-21	15	95 501 386 EE		01	95 595 300 FYC		51
AZ 841 128	08-9829-20	04		08-9225-11	11	95 501 386 FXX		01	95 595 955 NG	08-9220-23	03
AZ 971 67	08-9710-10	03	79 03 057 047	08-6132-10	16	95 501 386 NG		01	95 595 956 NG		03
	08-9713-11	25		08-6164-20	06	95 501 387 AR		01	95 595 957 NG		04
AZ 971 79	08-9710-10	07	79 03 057 061	08-6132-10	18	95 501 387 EE		01	95 595 958 NG		04
AZ 971 79 A		06	79 03 058 027		14	95 501 387 FXX		01	95 595 959 NG		53
AZ 971 88		13	79 03 058 028	08-9343-11	13	95 501 387 NG		01	95 595 960 NG		54
	08-9713-11	24	79 03 058 029	08-9225-11	12	95 508 073 AR	08-9829-20	01	95 595 961 NG	08-9348-13	03
AZ 971 90		02		08-9225-21	16	95 508 073 EE		01	95 595 962 NG		02
	08-9710-10	14	79 03 058 031	08-6132-10	17	95 508 073 FXX		01	95 596 981 DB	08-9713-11	01
AZ 971 98		18	79 03 061 999	08-9343-11	12	95 508 073 NG		01	95 596 981 EAA		01
AZ 971 98 A		18	79 03 072 150	08-6164-20	04	95 508 077 AR		01	95 596 981 EKB		01
AZ 982 270 A	08-9796-10	08	79 03 077 078	08-5541-10	63	95 508 077 EE		01	95 596 981 EVP		01
AZ 986 245 A		10	79 03 101 771	08-9225-21	14	95 508 077 FXX		01	95 596 981 FMB		01
AZ 986 246 A		10		08-9225-11	09	95 508 077 NG		01		08-9710-10	51
AZ 986 296 A		07	79 03 201 139	08-9343-11	11	95 575 739 SB	08-9220-23	01	95 596 981 NW	08-9713-11	01
AZ 986 297 A		07	79 20 070 298	08-6132-10	02	95 575 744 SB		02	95 596 981 VT		01
AZ 987 75		04	95 476 310 FXX	08-9222-13	03	95 575 751 FYC	08-9348-13	01	95 596 981 WB		01
ZC 9615 725 U	08-9710-10	20	95 476 314 FXX		02			51	95 596 986 VT	08-9710-10	01
ZC 9621 151 W	08-5541-10	08	95 500 736 FXX	08-9348-13	01	95 575 751 TL		51	95 599 291 EC	08-9220-23	52
ZF 11 087 876		06	95 500 948 AR	08-9828-10	01			01	95 599 292 EC		52
75 510 599*700	08-9220-23	01	95 500 948 EC		51	95 582 737 FXX	08-9220-23	01	95 599 293 EC	08-9348-13	51
75 522 585*322		01	95 500 948 EE		01	95 582 738 FXX		01	95 602 952 KB	08-9713-11	51
75 522 585*348		01	95 500 948 FDA		51	95 582 781 FYC		01	95 602 952 MB		51
75 522 585*841		01	95 500 948 FXX		01	95 582 781 TL		01	95 602 952 NA		51
75 522 585*846		01	95 500 948 FYC		51			51	95 602 952 NW		51
75 522 585*900		01	95 500 948 NG		51	95 582 782 FYC		01	95 602 952 VM		51
75 522 586*348		02	95 500 949 AR		01	95 582 782 TL		01	95 602 952 WT		51
75 522 586*841		02	95 500 949 EC		51	95 582 789 AN		01	95 607 754 EC	08-9348-13	51
75 522 586*846		02	95 500 949 EE		01	95 582 789 AP		01	95 607 754 LH		51
75 522 587*322		01	95 500 949 FDA		51	95 582 789 LR		01	95 607 755 EC	08-9220-23	52
75 522 587*348		01	95 500 949 FXX		01	95 582 789 PH		01	95 607 755 LH		52
75 522 587*841		01	95 500 949 FYC		51	95 582 790 AN		01	95 607 756 EC		52
75 522 587*846		01	95 500 949 NG		51	95 582 790 AP		01	95 607 756 LH		52
75 522 587*900		01	95 500 954 AR	08-9829-20	01	95 582 790 LR		01	95 612 609 FLV		01
75 522 588*322	08-9348-13	01	95 500 954 EC		51	95 582 790 PH		01	95 612 610 FTM		01
75 522 588*348		01	95 500 954 EE		01	95 583 096 FXX		53	95 612 615 FLV		53
75 522 588*836		01	95 500 954 FDA		51	95 583 097 FXX		53	95 612 618 FLV		01
75 522 588*841		01	95 500 954 FXX		01	95 583 125 FYC		52	95 612 619 FLV		52
75 522 588*846		01	95 500 954 FYC		51	95 583 125 TL		52	95 612 620 FTM		01
77 01 000 955	08-6164-20	07	95 500 954 NG		51	95 583 446 FXX		52	95 612 621 FTM		52
79 03 007 073	08-6132-10	07	95 500 955 AR		01	95 584 339 AN	08-9348-13	01	95 612 628 FLV		53
79 03 007 103	08-5541-10	09	95 500 955 EC		51	95 584 339 AP		01	95 612 633 FLV	08-9222-13	02
79 03 016 008	08-9710-10	19	95 500 955 EE		01	95 584 339 LR		01	95 612 634 FLV	08-9220-23	54
79 03 016 140	08-9713-11	29	95 500 955 FDA		51	95 593 807 NG		04	95 612 635 FLV	08-9222-13	03
	08-6132-10	09	95 500 955 FXX		01	95 595 270 AS	08-9220-23	01	95 612 641 FLV	08-9348-13	01
79 03 032 006		20	95 500 955 FYC		51	95 595 270 FYC		52	95 612 642 FTM		01
79 03 044 023	08-9713-11	15	95 500 955 NG		51	95 595 271 AS		01	95 612 643 FLV		03
79 03 053 025	08-5541-10	10	95 501 269 FXX	08-9348-13	03	95 595 274 AS		52	95 612 646 FLV		02
79 03 053 121	08-6164-20	08	95 501 270 FXX		02	95 595 274 FYC		52	95 612 768 FTM	08-9828-10	01



B06 ↑

INDEX

Catalogue 1117

NUMERO	SOUS-GROUPE	REP	NUMERO	SOUS-GROUPE	REP
95 612 769 FTM		01			
95 612 772 FTM		01			
95 612 773 FTM		01			
95 612 776 FTM	08-9829-20	01			
95 612 777 FTM		01			
95 612 780 FTM		01			
95 612 781 FTM		01			
95 634 902 FDA	08-9348-13	51			
95 634 903 FDA	08-9220-23	52			
95 634 904 FDA		52			
95 638 067 XX	08-8164-20	02			
95 640 163 LV	08-9222-13	03			
95 640 164 LV		02			
95 640 166 LV	08-9220-23	54			
95 640 167 LV		53			
95 640 168 LV		53			
95 640 169 LV	08-9348-13	02			
95 640 170 LV		03			
95 640 173 LV		01			
95 640 174 TM		01			
95 640 179 TM	08-9220-23	52			
95 640 180 LV		52			
95 640 187 TM		01			
95 640 188 TM		01			
95 640 189 LV		01			
95 640 190 LV		01			
96 013 247 DA		52			
96 013 248 DA		52			
96 013 249 DA	08-9348-13	51			
96 026 443 YC	08-9220-23	52			
96 026 444 YC		52			
96 026 448 YC	08-9348-13	51			

*Der Franzose*